

# MATRIPELLE M A T R I P E L L E A R C H I T E C T U R E

Trè Notre-Dame-de-Paris Cathedra  
La Catedrala Notre-Dame de Paris  
La Catedral da Notre-Dame-de-Paris  
De Katedral Notre-Dame-de-Paris  
Das Notre-Dame-Kathedrale in Paris  
La cathédrale di Notre-Dame di Parigi



SALETTI  
L'ARTE  
DE  
L'EDIFICAZIONE

## The Notre-Dame-de-Paris Cathedral

Host of some of the greatest political and religious events in France, the Notre-Dame-de-Paris Cathedral has undergone several architectural reconstructions since its choir was built in 1177.  
The construction spanned more than 500 years.

## Cattedrale Notre-Dame de Paris

Host des plus grands événements politiques et religieux de la France, la cathédrale Notre-Dame de Paris a subi, depuis la fin de la construction de son chœur en 1177, plusieurs transformations architecturales.  
Les travaux se sont étendus sur une période de plus de 500 ans.

## La Catedral de Notre-Dame-de-Paris

Site de algunos de los eventos políticos y religiosos más importantes de Francia, la Catedral de María-Dama-de-París ha sido reconstruida varias veces desde la construcción de su coro en 1177.  
La construcción se prolongó más de 500 años.

## Die Notre Dame Kathedrale in Paris

Als Gastgeber für einige der größten politischen und religiösen Ereignisse in Frankreich wurde die Notre Dame Kathedrale in Paris seit ihrer Erringer im Jahr 1177 gebaut wurde. Einige architektonischen Umbaumaßnahmen unterzogen. Der Bauarbeiten erstreckten sich über mehr als 500 Jahre.

## De Kathedraal Notre-Dame-de-Paris

In de kathedraal Marie-Dame-de-Paris vinden sommige van de belangrijkste politieke en religieuze gebeurtenissen van Frankrijk plaats. Sinds de bouw van het koor in 1177, heeft de kathedraal diverse architecturale reconstructies ondergaan.  
De hele bouwperiode bedroeg meer dan 500 jaar.

## La cattedrale di Notre Dame di Parigi

Tempore dei più grandi avvenimenti politici e religiosi della Francia, la cattedrale di Notre Dame di Parigi ha subito, dalla costruzione del coro nel 1177, diverse modifiche architettoniche.  
I lavori si sono protratti per oltre 500 anni.

## パリ、ノートルダム寺院

1177年に聖歌隊が結成されて以来、フランスにおける偉大な政治および宗教的イベントが催されてきたパリのノートルダム寺院は、建築物の改築を何度も経験してきました。その建設は、900年以上にも渡り、待筆すべき出来事として次のようなことがありました。

## PLANS • PLANOS • PIANI • ZEICHNUNGEN • PLANEN • 設計図

# MATCHITECTURE

### Contents:

- 1 assembly sheet with clear outside sheet
- 4 clips
- 1 MICROBAM cutter
- 7500 MICROBAMS (2.1W/53 mm)
- 2 bottles of wood glue (4 oz/120 ml)
- 1 MICROBAM tweezers
- plans
- instructions

### Contenu :

- 1 planche d'assemblage avec feuille d'outside transparente
- 4 clips
- 1 coupe-MICROMAGNER
- 7500 MICROMAGNETS (53 mm/2.1W)
- 2 bouteilles de colle à bois (120 ml/4 oz)
- 1 pince à MICROMAGNETS
- plans
- instructions

### Contenido:

- 1 tablero de ensamblaje con hoja de outside transparente
- 4 clips
- 1 cortamicrometa
- 7500 MICROBAMS (53 mm/2.1W)
- 2 botellas de pegamento de madera (120 ml/4 oz)
- 1 pincel para MICROBAMS
- planes
- instrucciones

### Inhalt:

- 1 montageplatte mit durchsichtigem Acrylblech
- 4 clips
- 1 MINROSITBSchneidwerk
- 7500 MINROSITBES (53 mm/2.1W)
- 2 Flaschen Holzkleber (120 ml/4 oz)
- 1 pinzette für die MINROSITBES
- zeichnungen
- vorlagen

### Inhoud:

- 1 montageplaat met transparent blad van acryal
- 4 klempen
- 1 snider voor MICROBALKES
- 7500 MICROBALKES (53 mm/2.1W)
- 2 flessen houtlijm (120 ml/4 oz)
- 1 pincel voor MICROBALKES
- plannen
- gebruiksaanwijzingen

### 内容:

- 1 透明シートと組み立てボード
- 4 クリップ
- 1 マイクロビームカッター
- 7500 マイクロビーム (53mm/2.1W)
- 2 木工用糊 (120ml/4oz)
- 1 マイクロビームピンセット
- 設計図
- 使用説明書

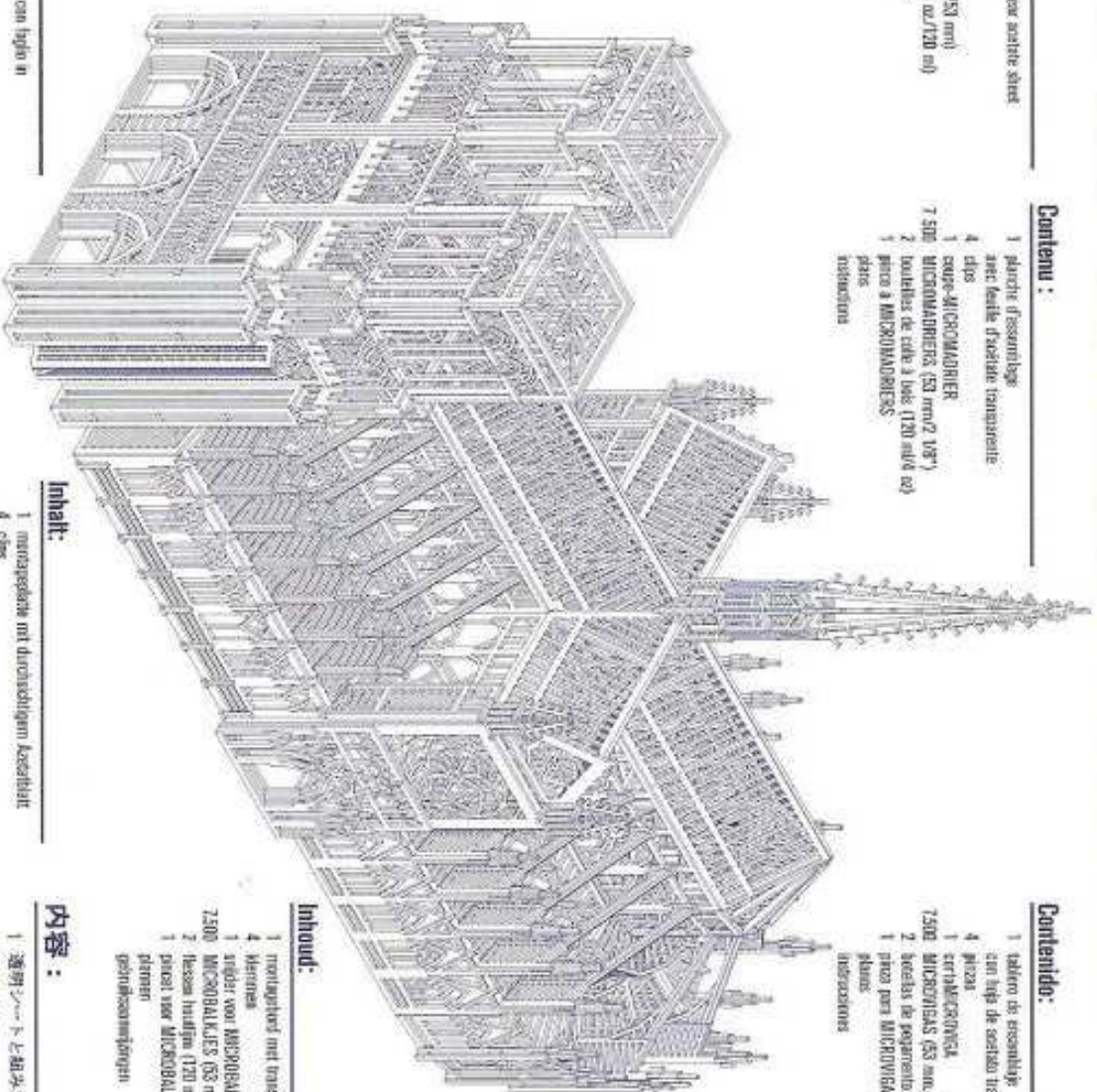

### Contenuto:

- 1 tavolo d'assemblaggio con foglio in acrilico trasparente
- 4 clippe
- 1 tagliatrice per MICROBAM
- 7500 MICROBAM (53 mm/2.1W)
- 2 bottiglie di colla per legno (120 ml/4 oz)
- 1 pinzetta per MICROBAM
- plani
- instruzioni

### Inhalt:

- 1 montageplatte mit durchsichtigem Acrylblech
- 4 clips
- 1 MINROSITBSchneidwerk
- 7500 MINROSITBES (53 mm/2.1W)
- 2 Flaschen Holzkleber (120 ml/4 oz)
- 1 pinzette für die MINROSITBES
- zeichnungen
- vorlagen

### Inhoud:

- 1 montageplaat met transparent blad van acryal
- 4 klempen
- 1 snider voor MICROBALKES
- 7500 MICROBALKES (53 mm/2.1W)
- 2 flessen houtlijm (120 ml/4 oz)
- 1 pincel voor MICROBALKES
- plannen
- gebruiksaanwijzingen

### 内容:

- 1 透明シートと組み立てボード
- 4 クリップ
- 1 マイクロビームカッター
- 7500 マイクロビーム (53mm/2.1W)
- 2 木工用糊 (120ml/4oz)
- 1 マイクロビームピンセット
- 設計図
- 使用説明書

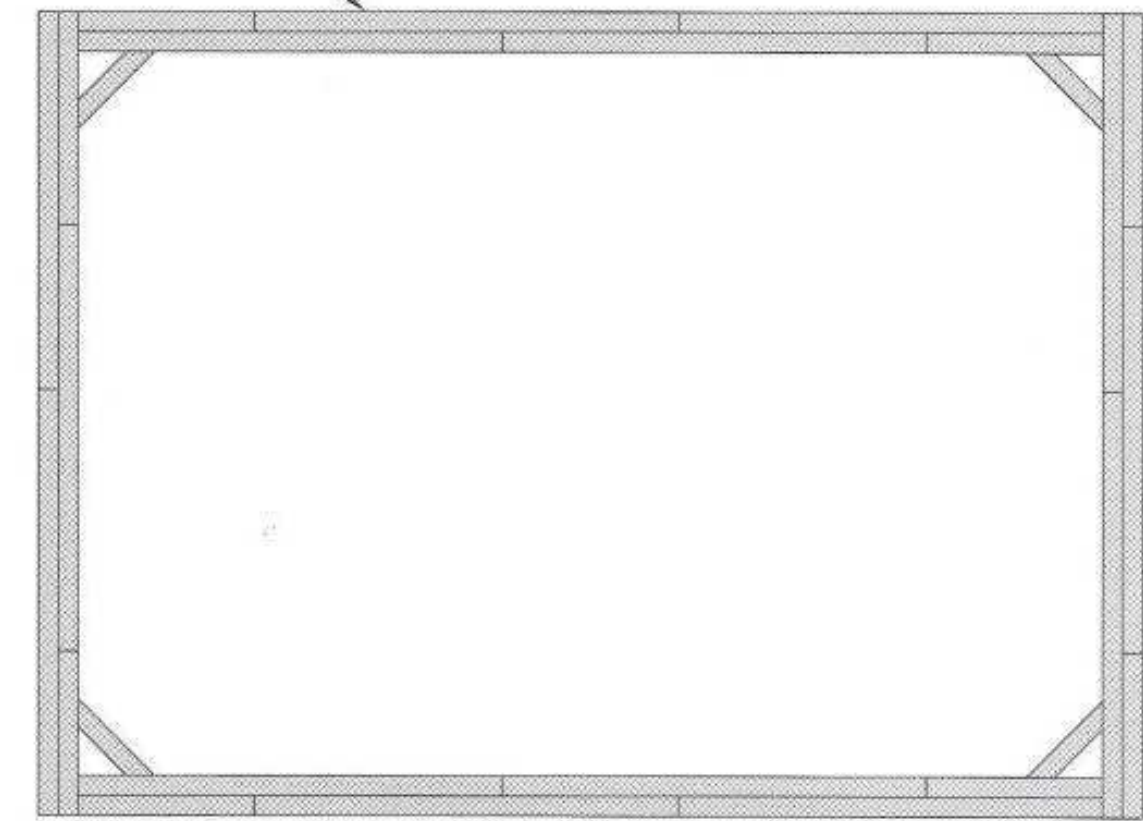

2x 1

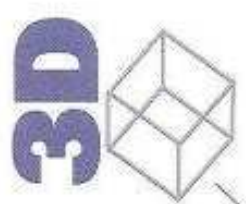

3D

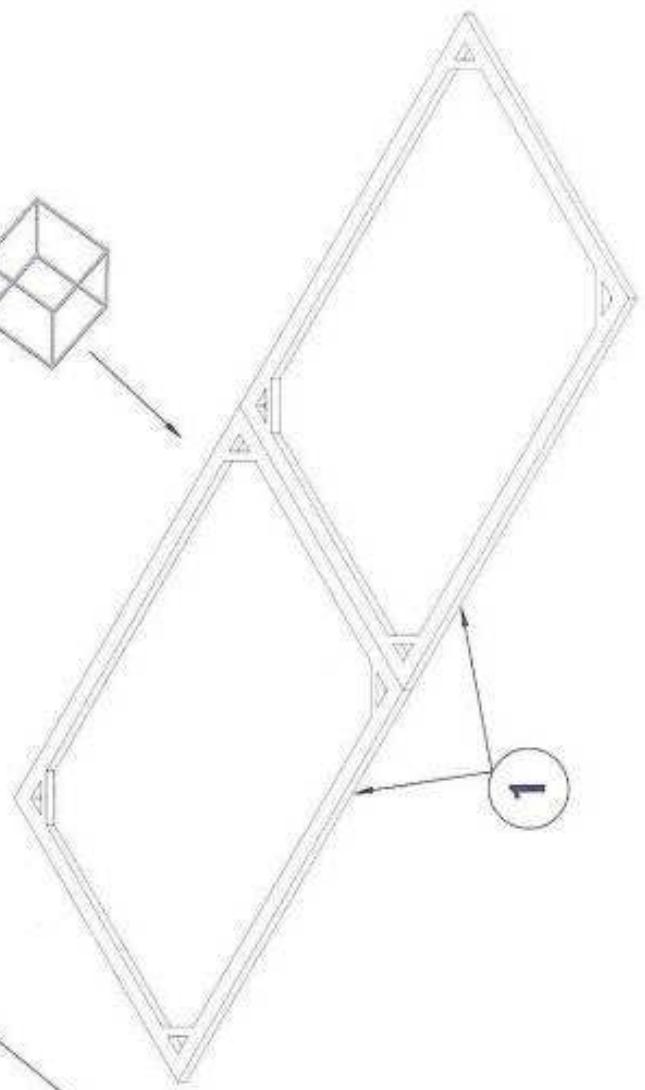

1

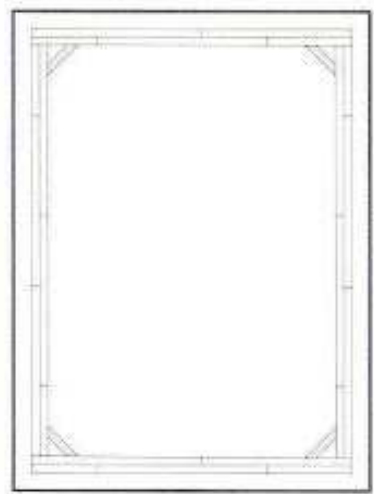

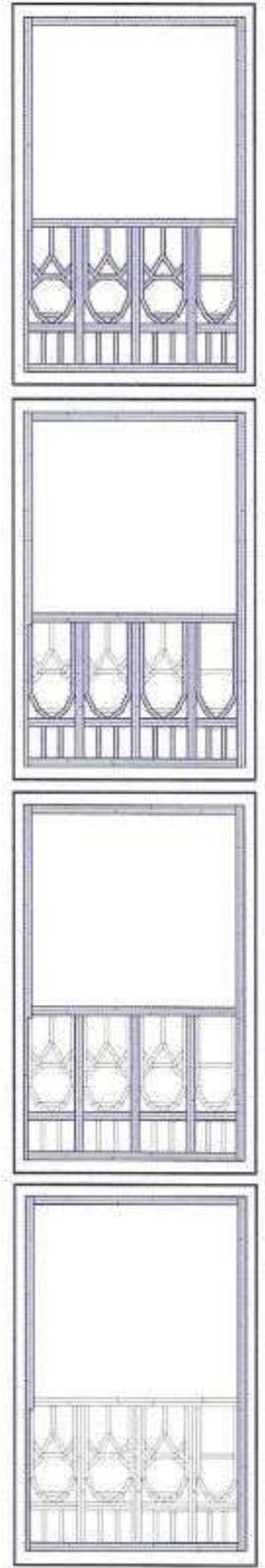
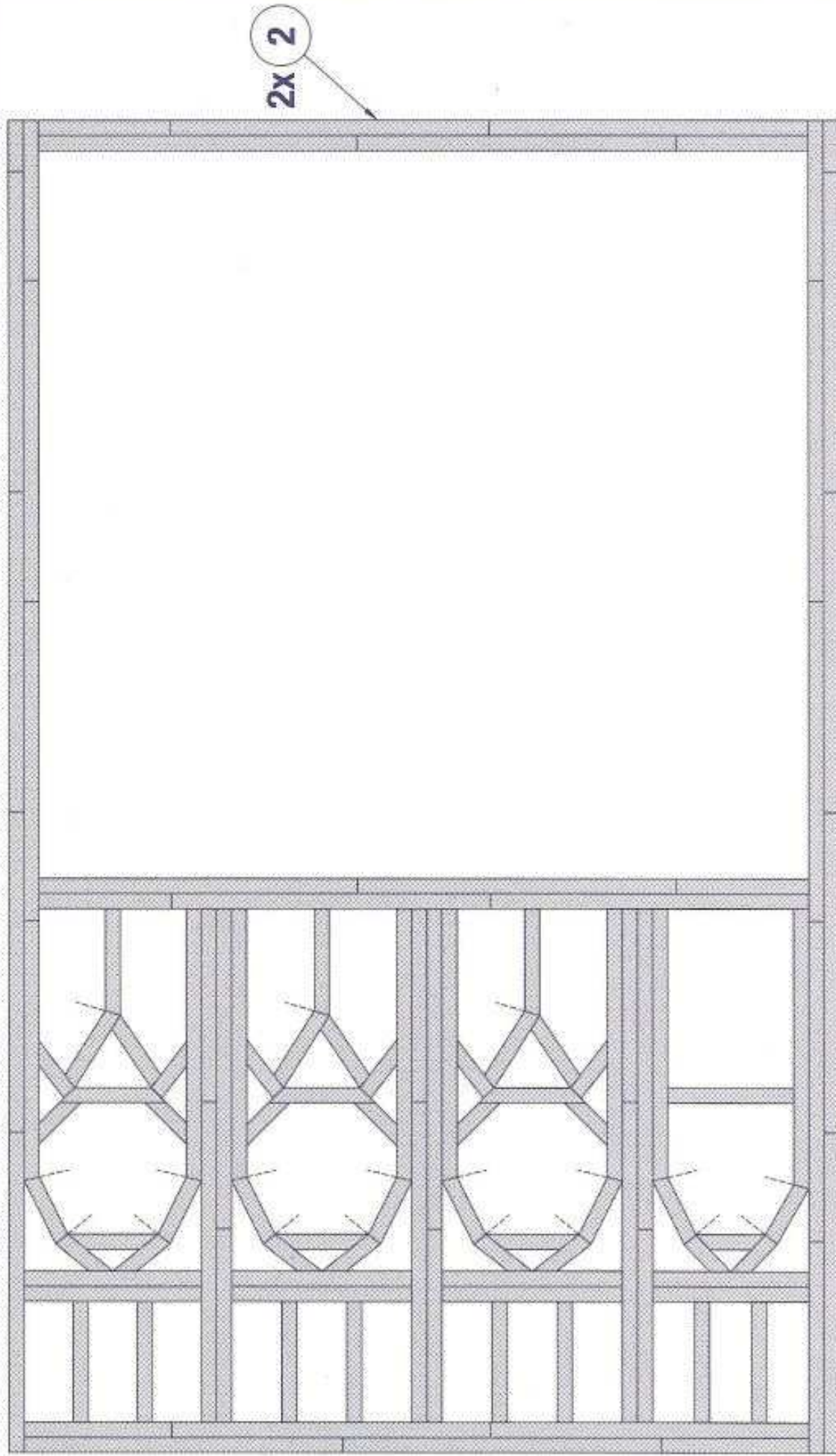

2x 3

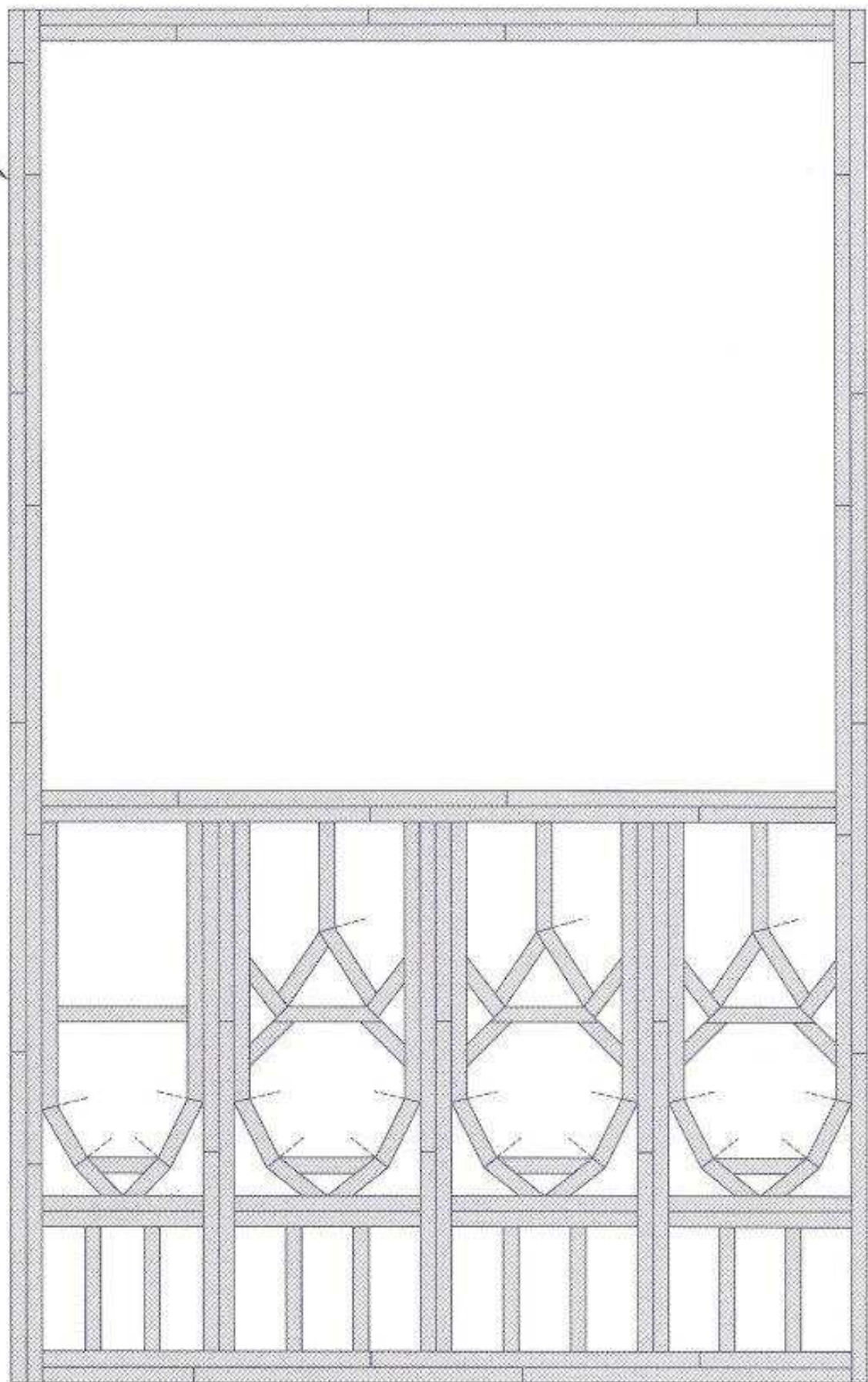

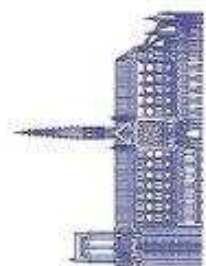
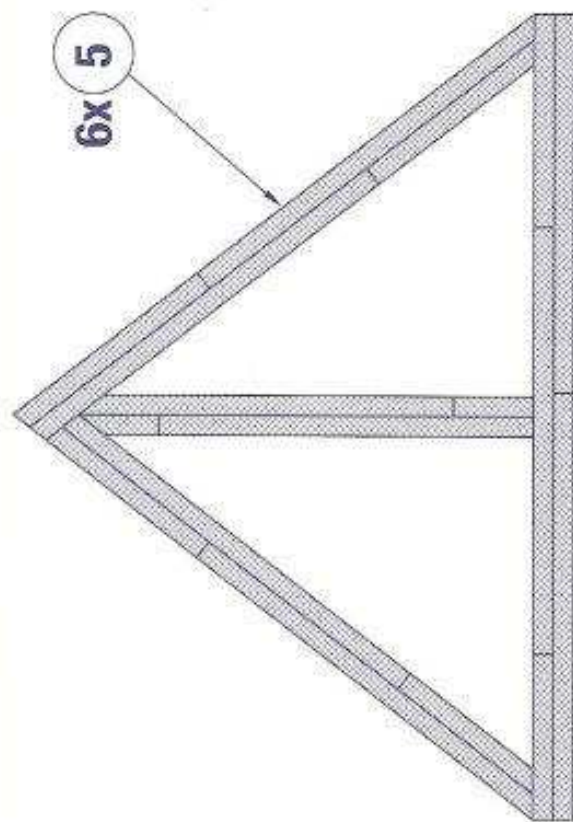
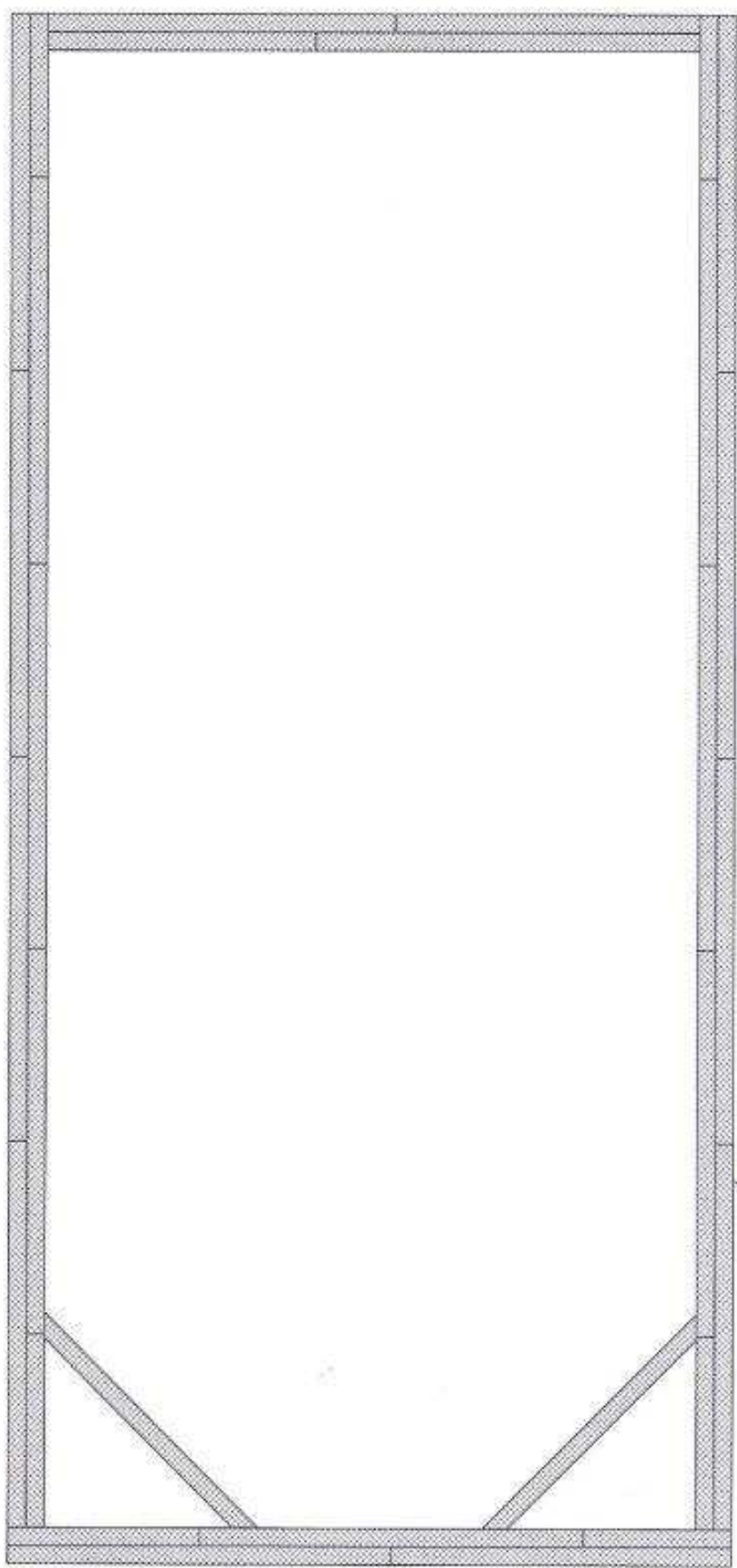

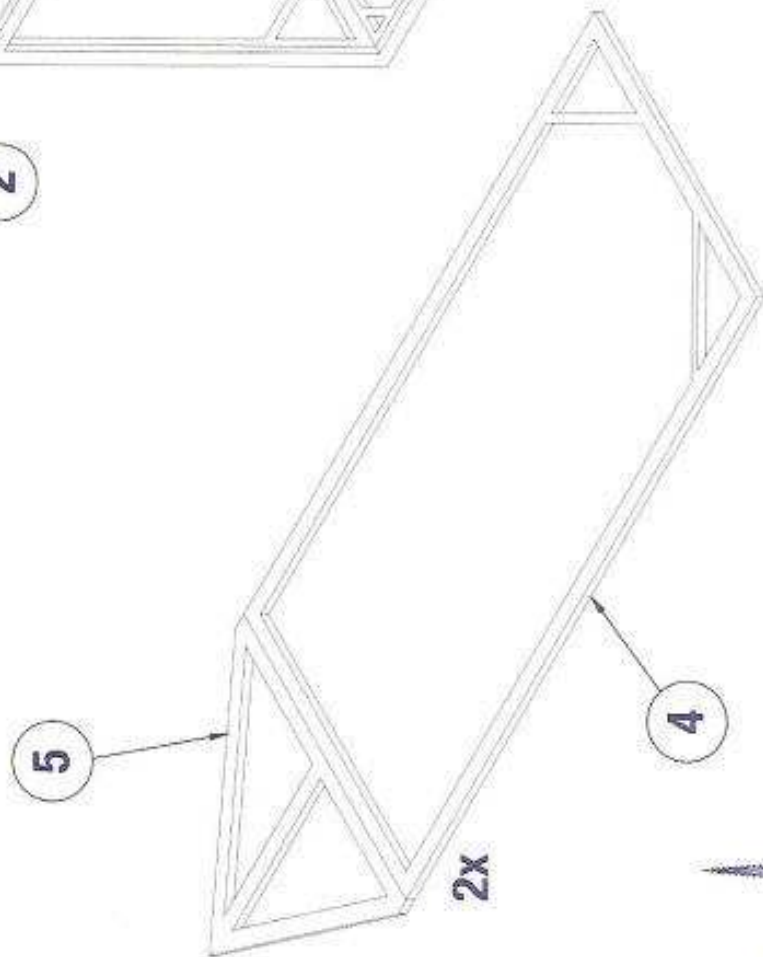
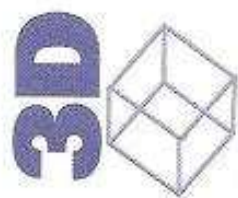
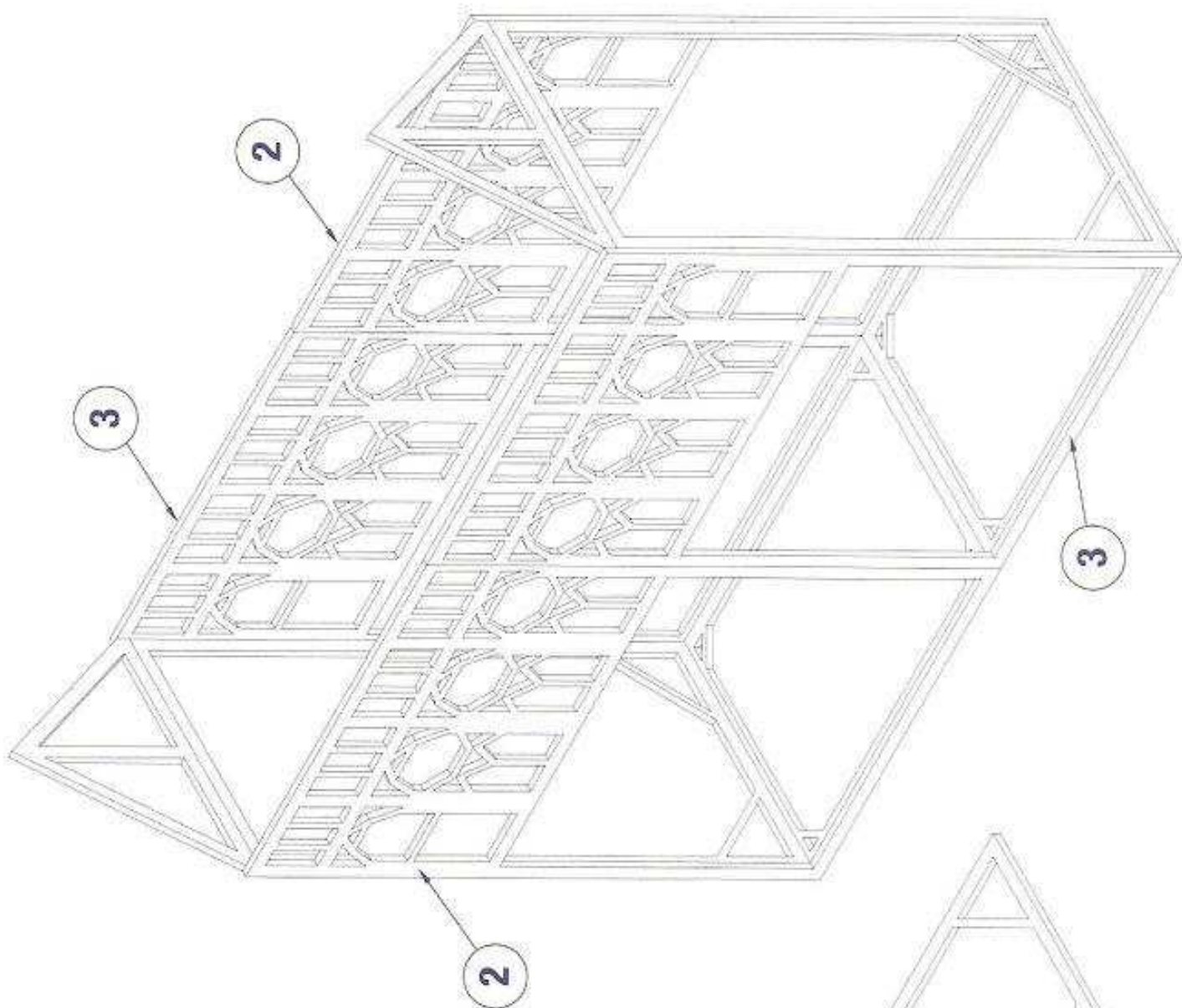

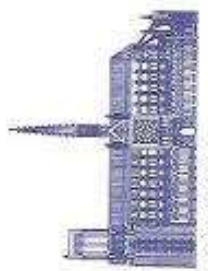
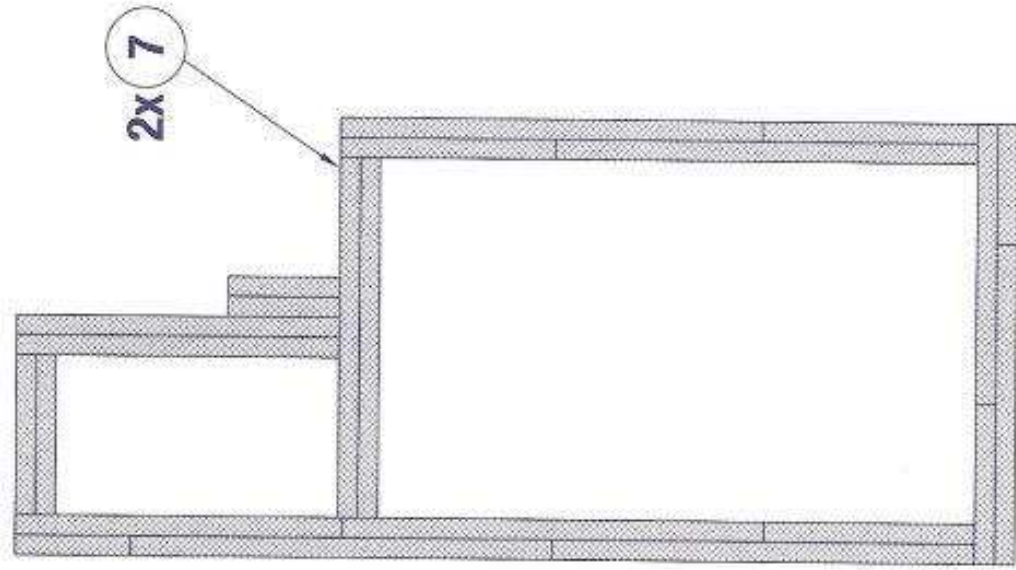
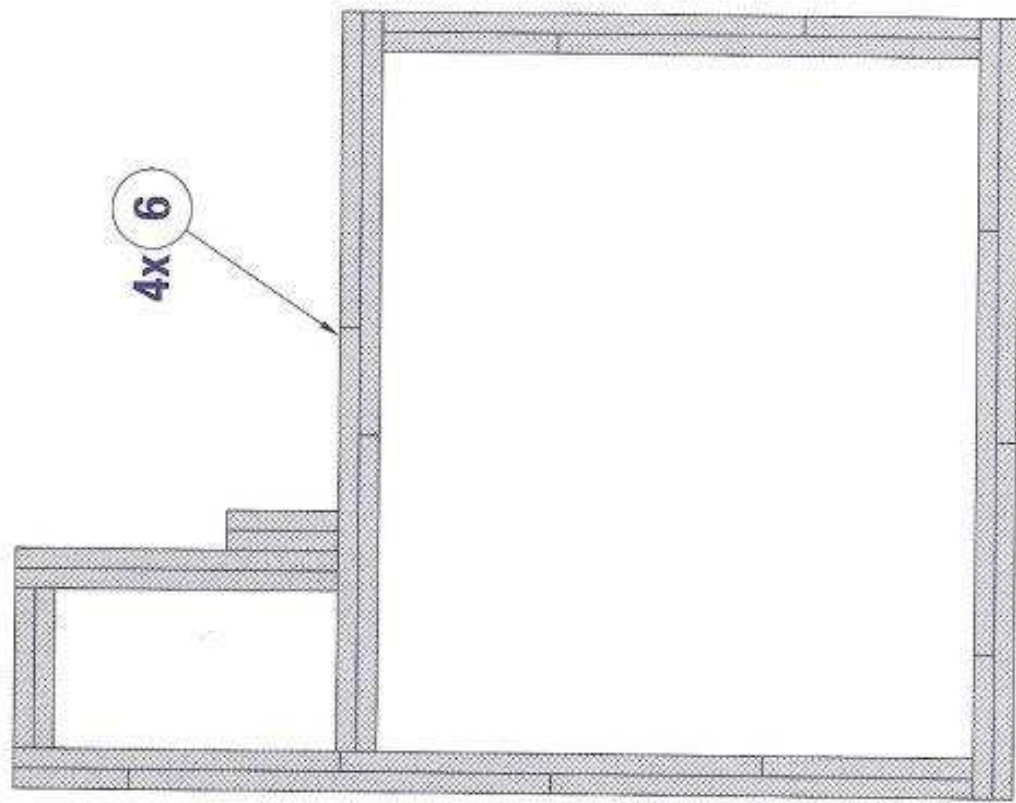

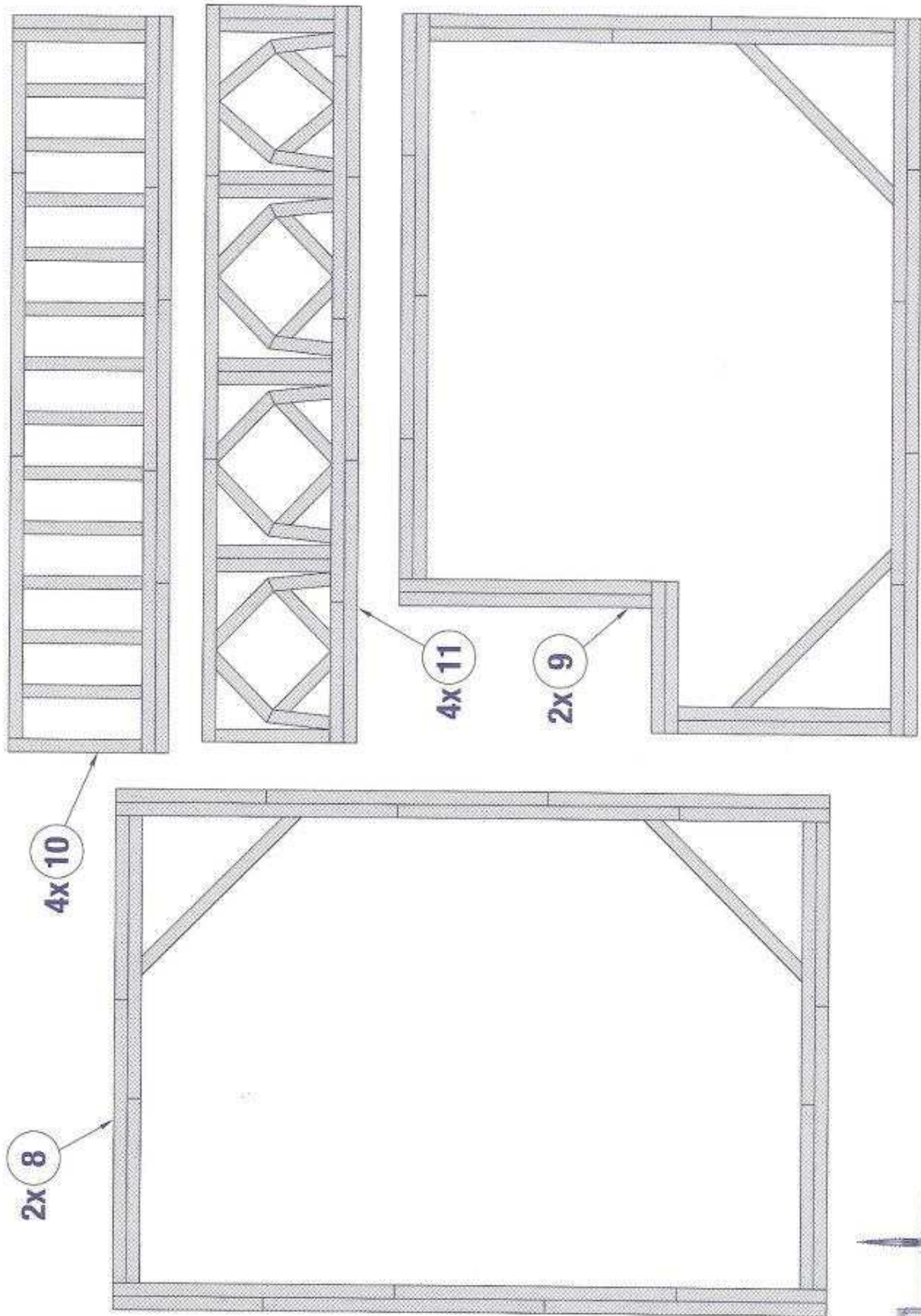

**3D**

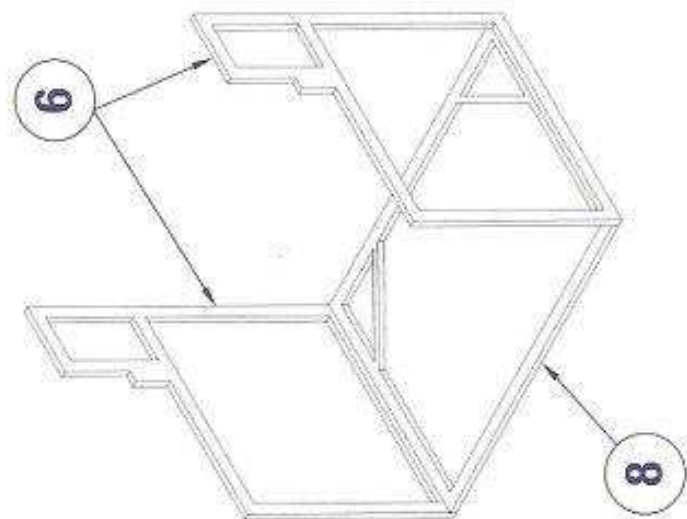

**2x**

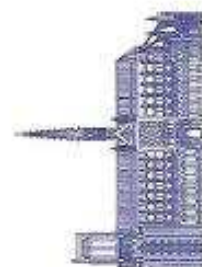
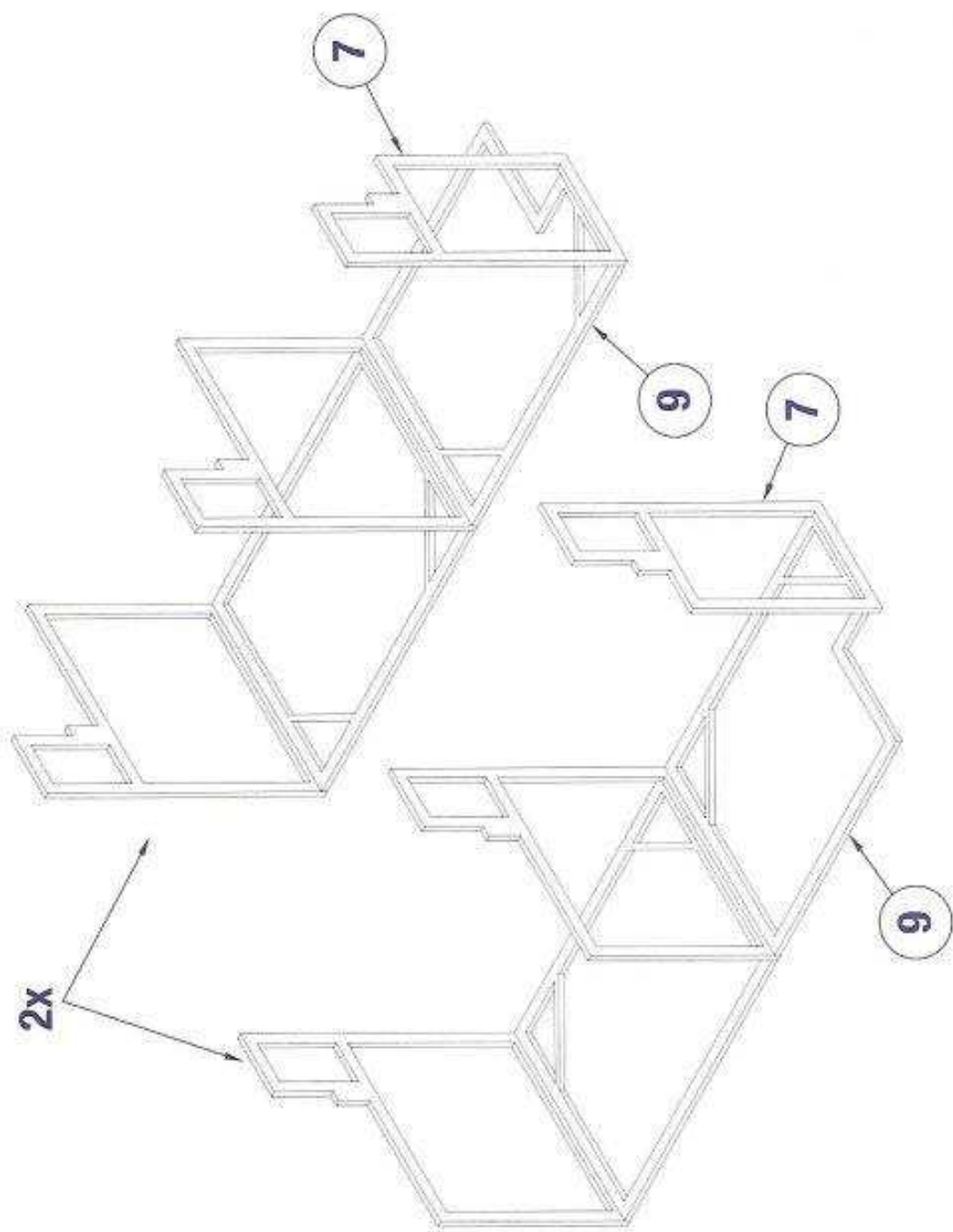

© 2006 Bujoux Inc.

[www.matchitecture.com](http://www.matchitecture.com)

**MATCHITECTURE**

**8** H05

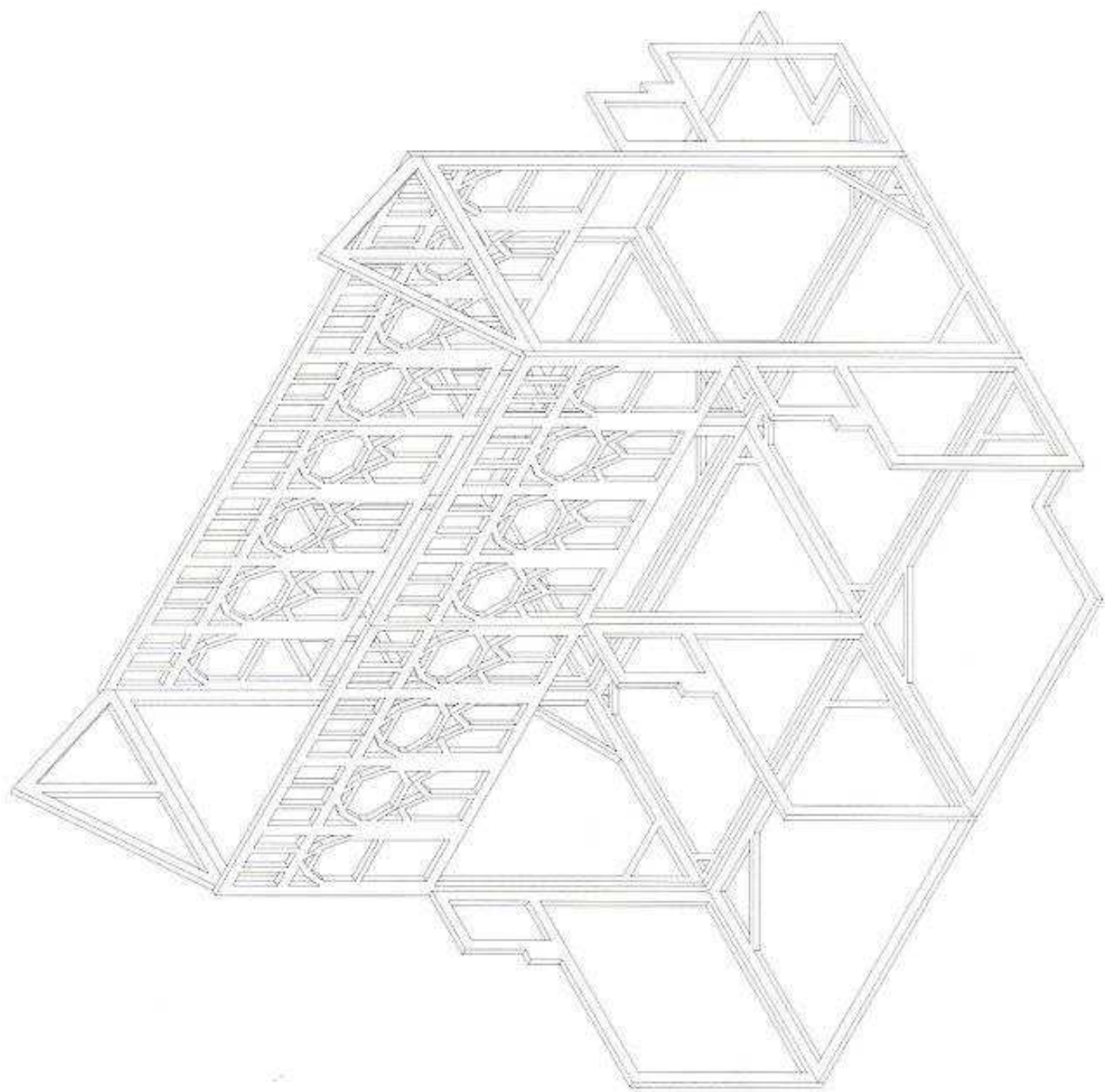
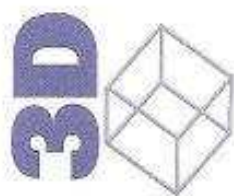

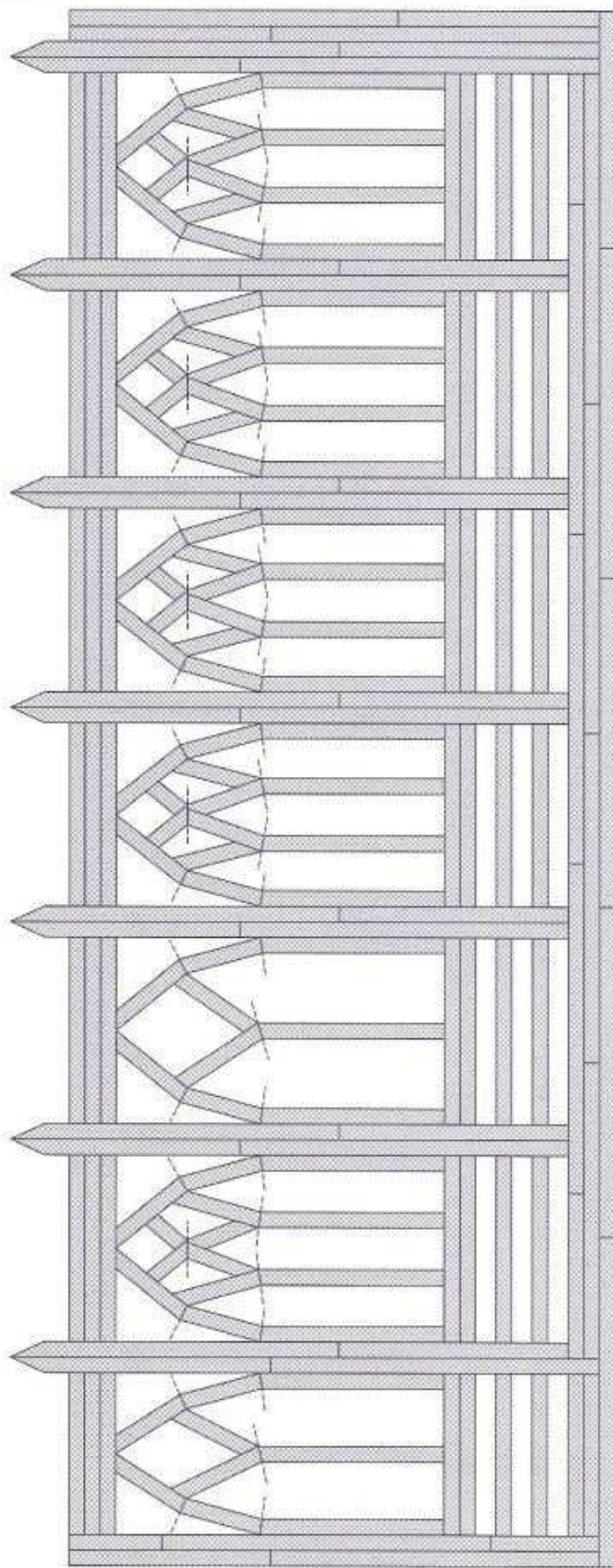

12

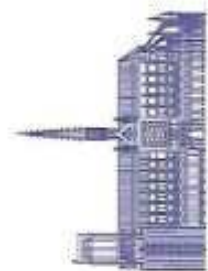

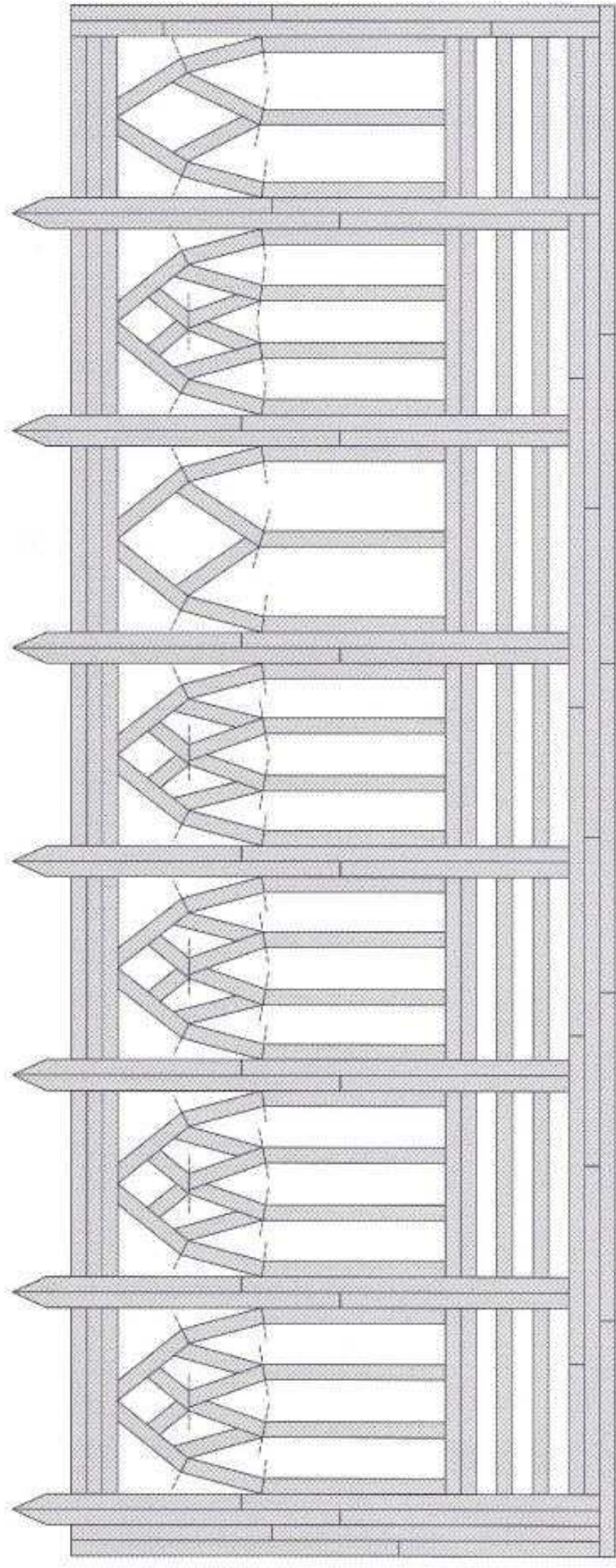

13



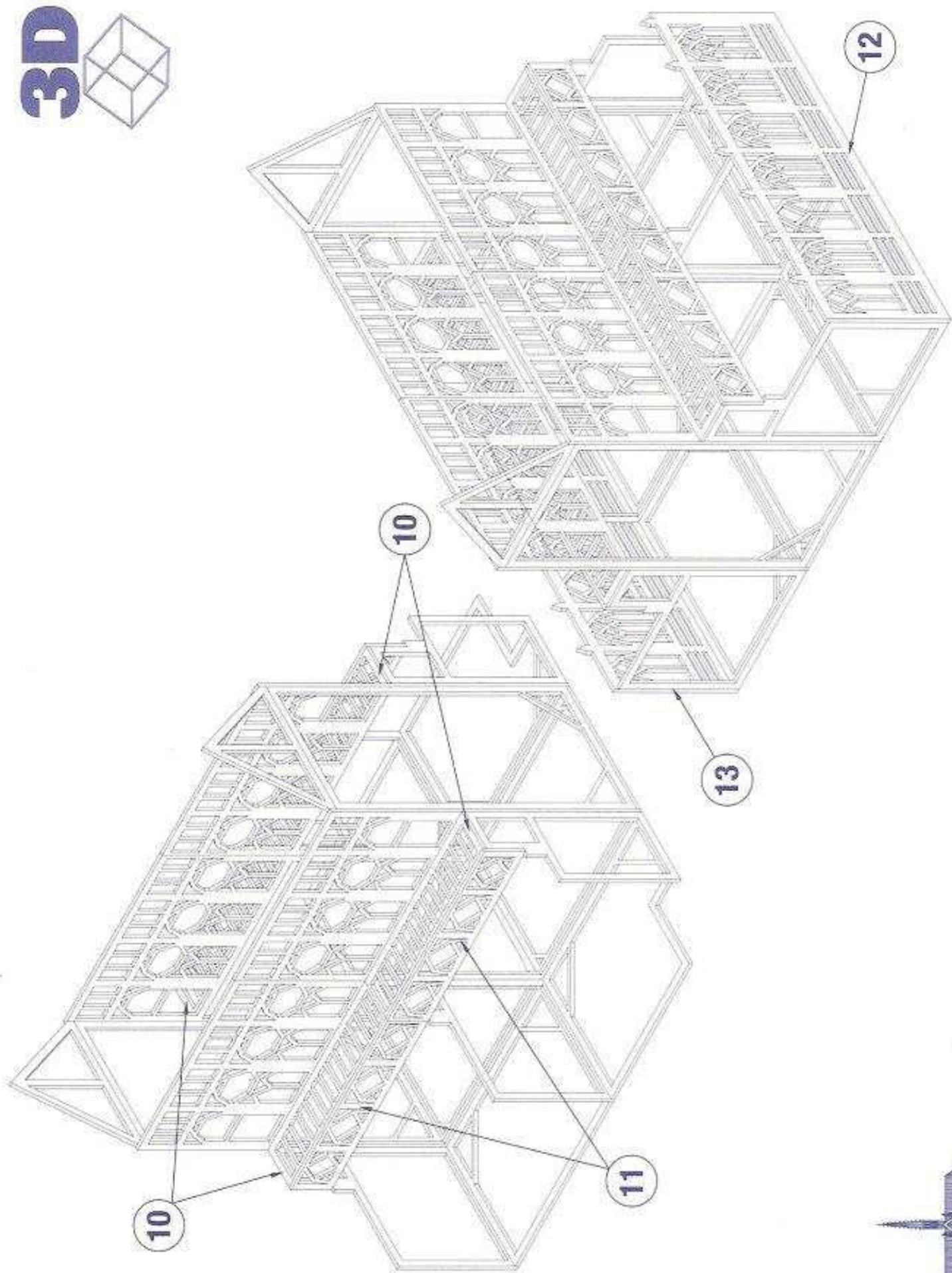
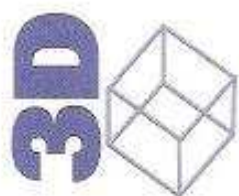

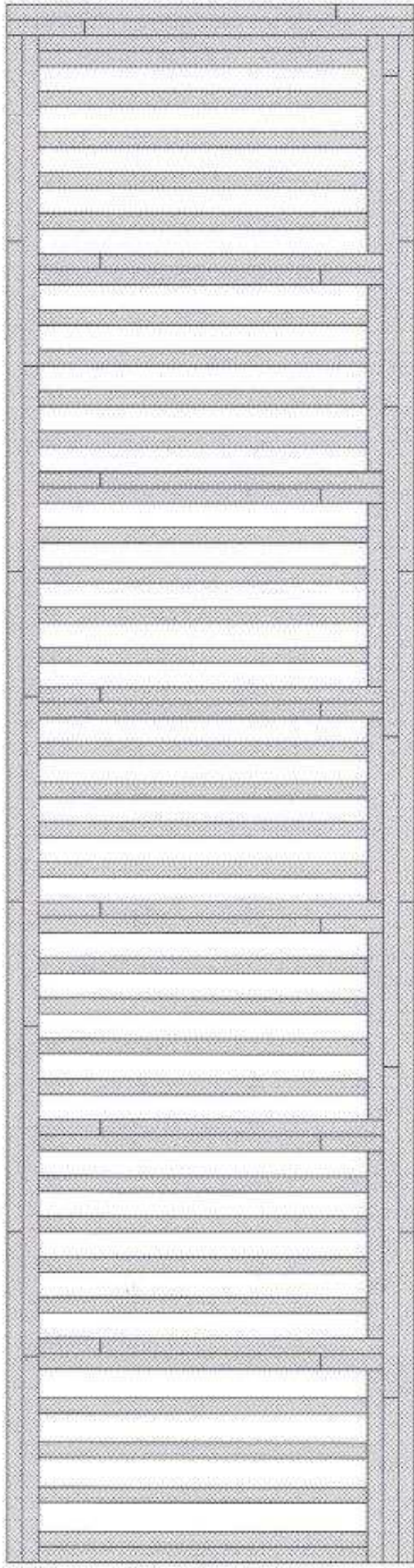

2x 14



2x 15

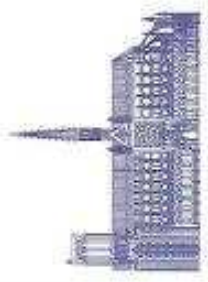

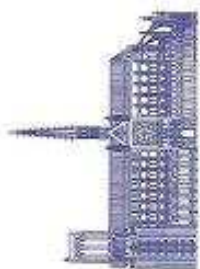
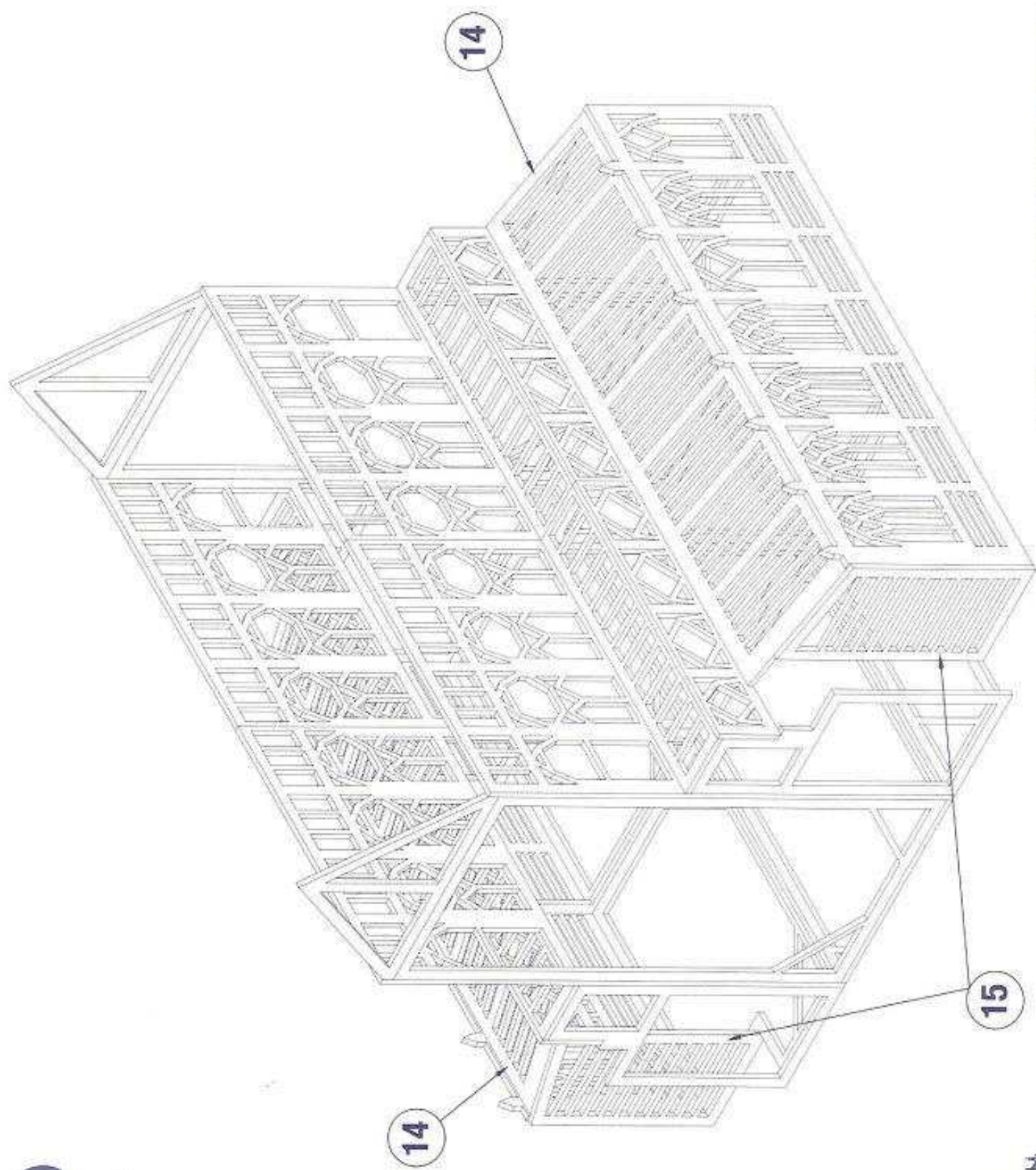
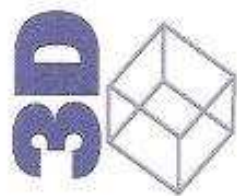

© 2006 Bojoux Inc.

[www.matchitecture.com](http://www.matchitecture.com)

MATCHITECTURE

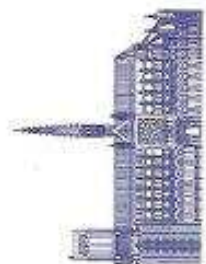
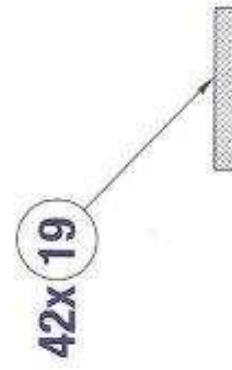
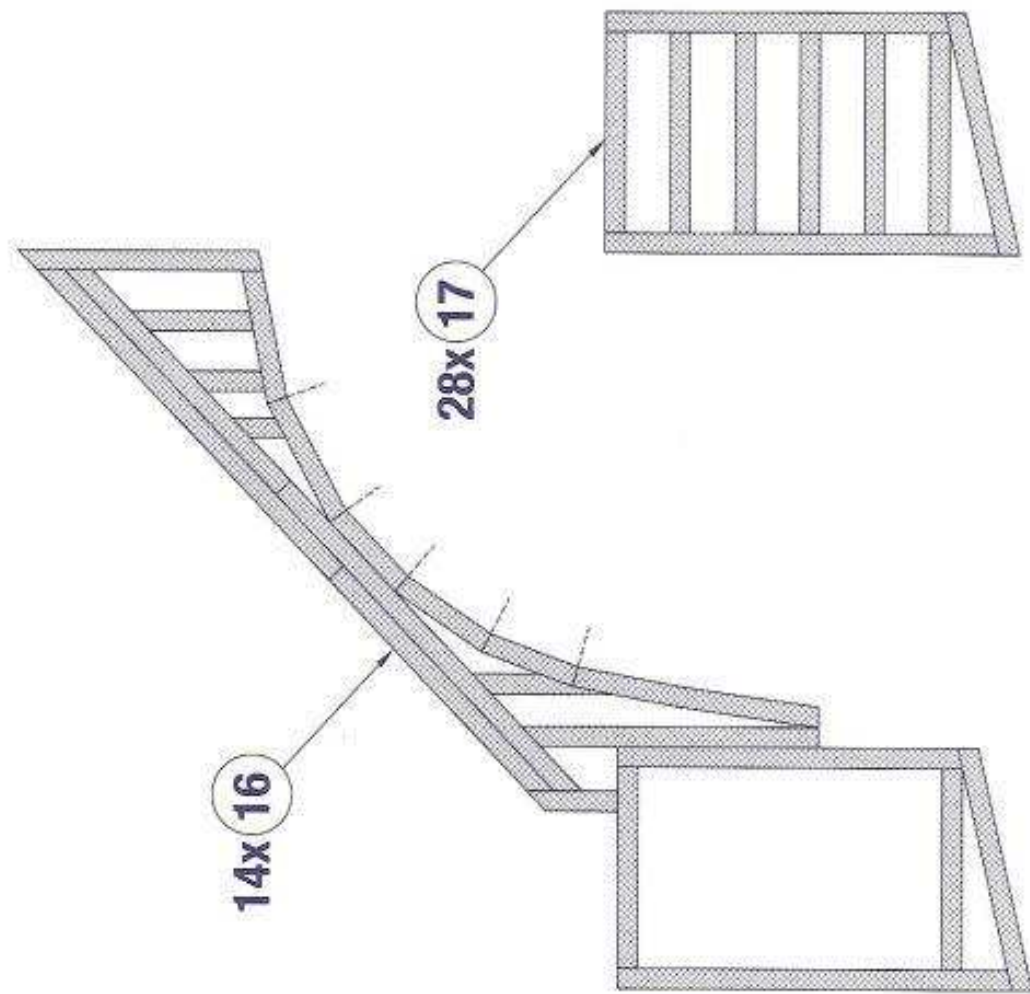

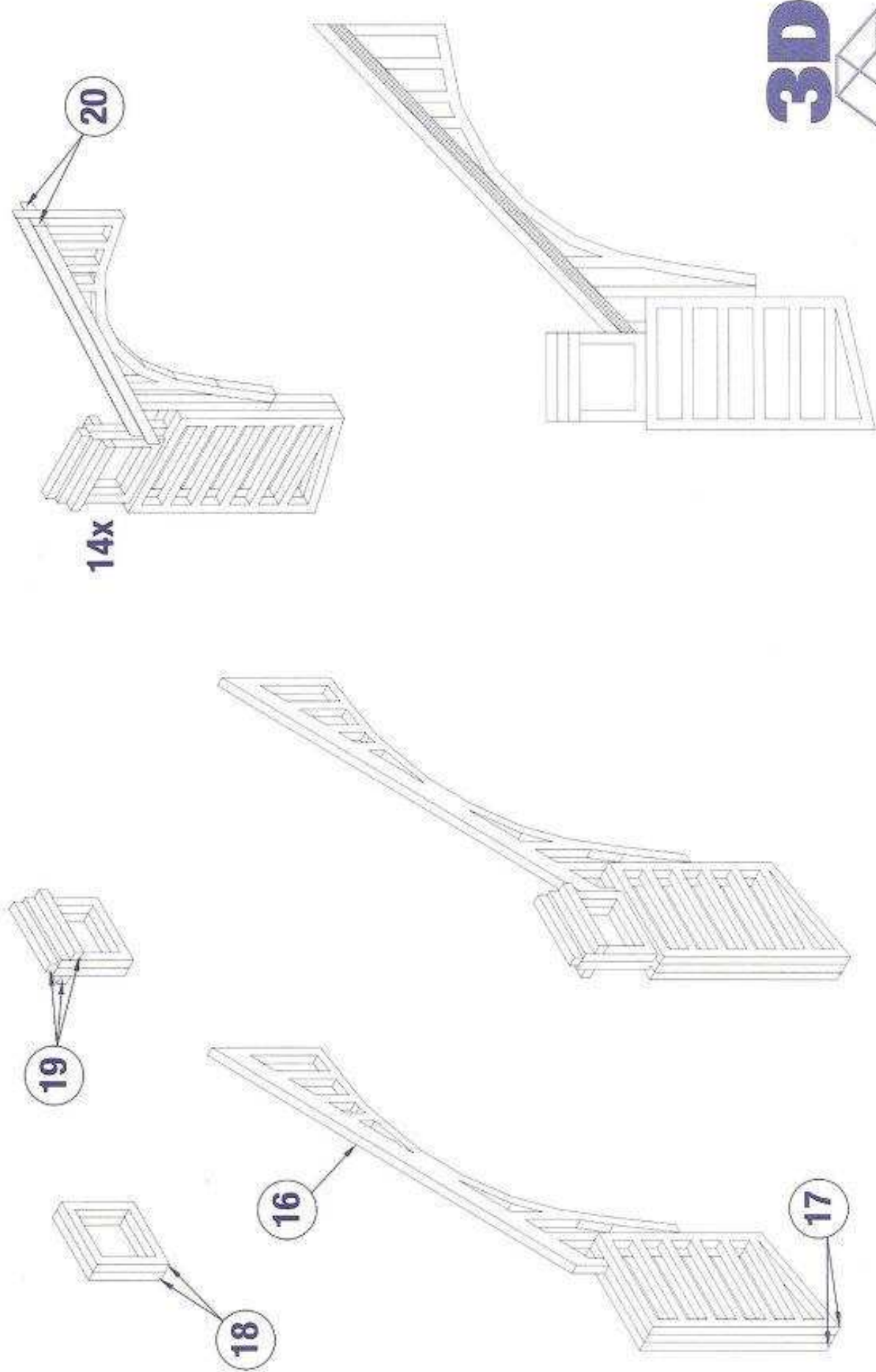

**3D**

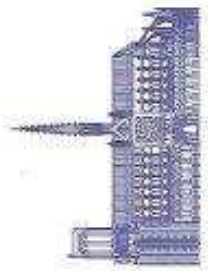

**3D**

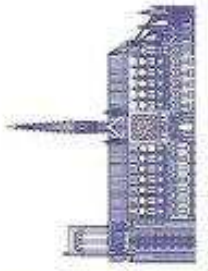
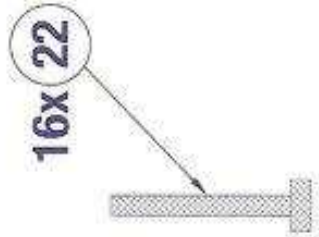
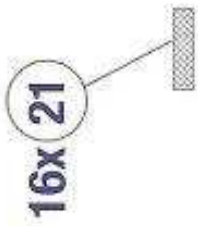
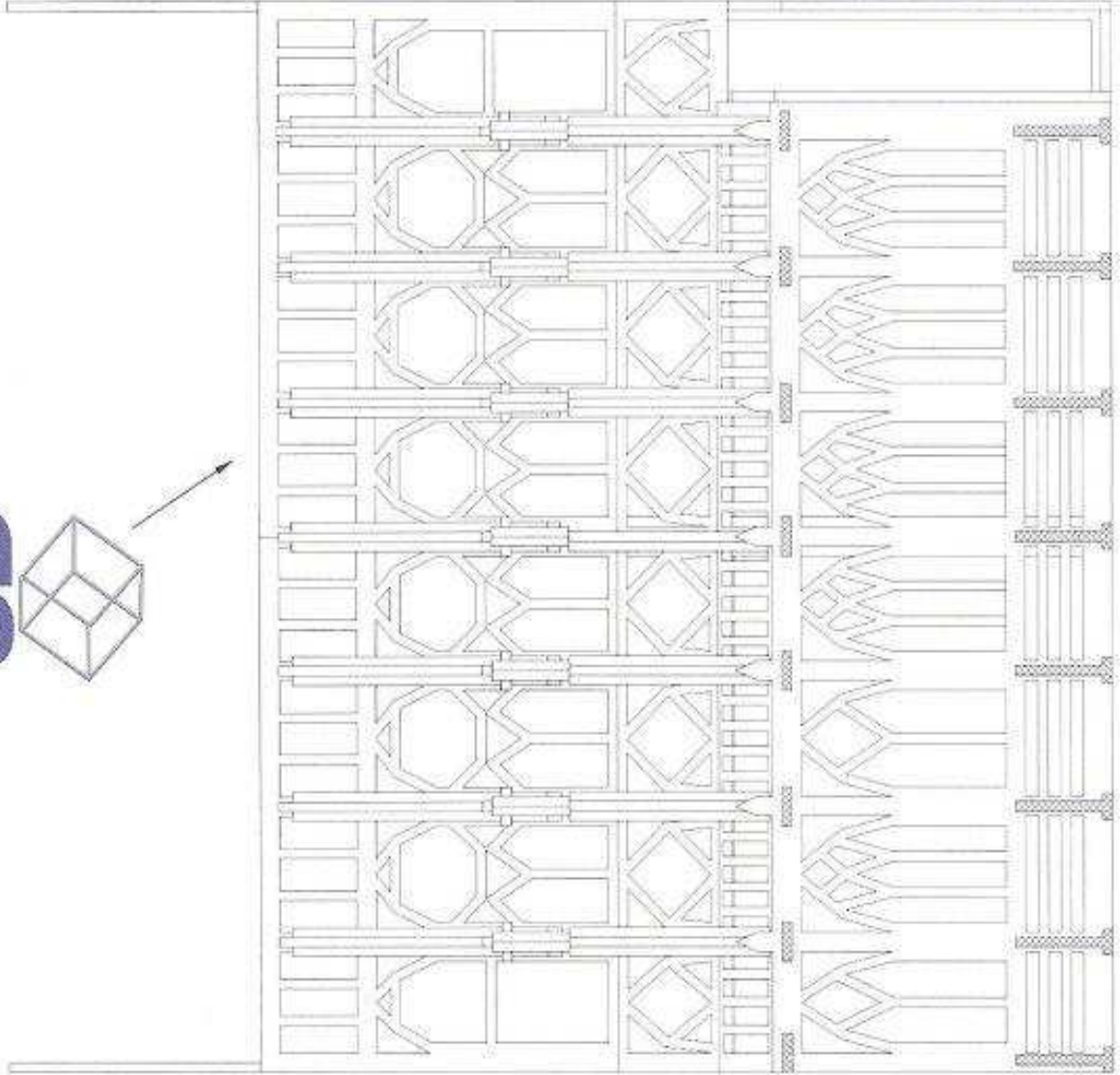

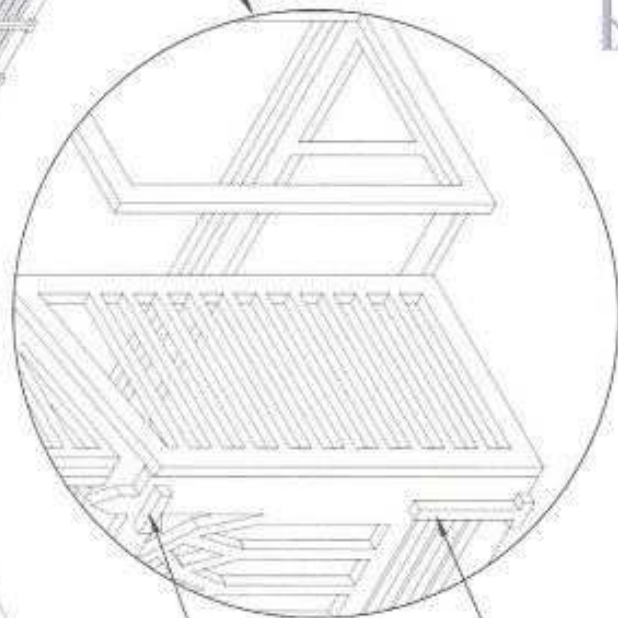
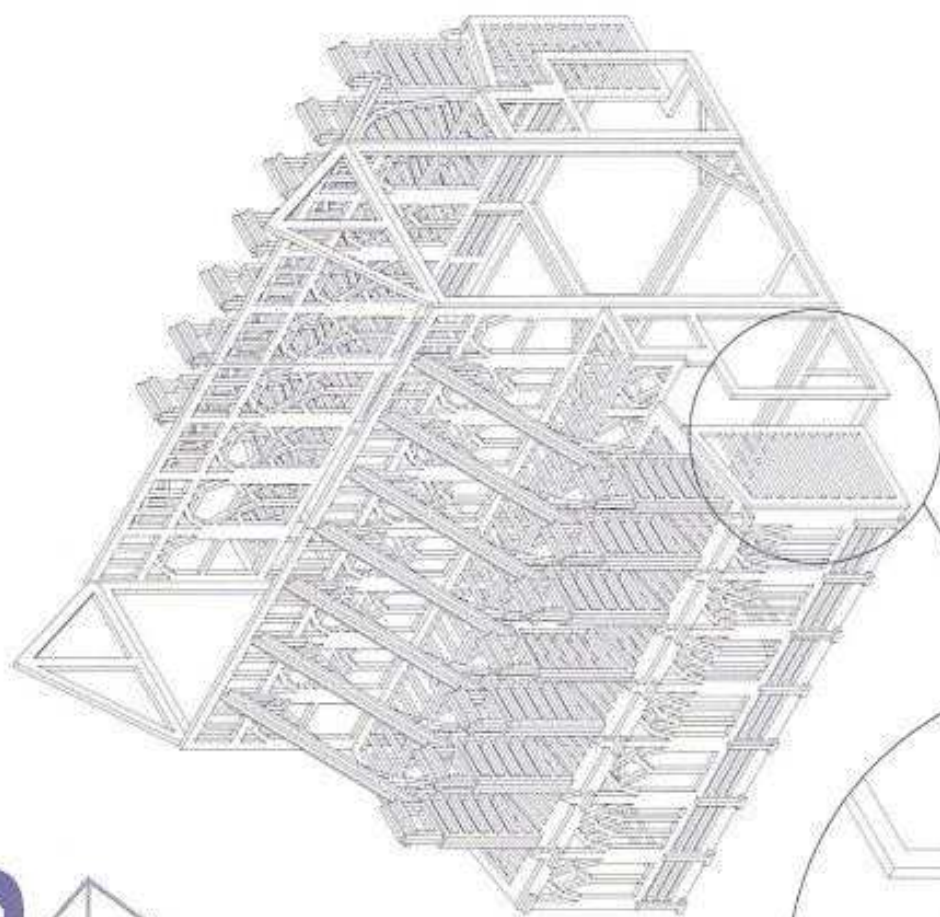
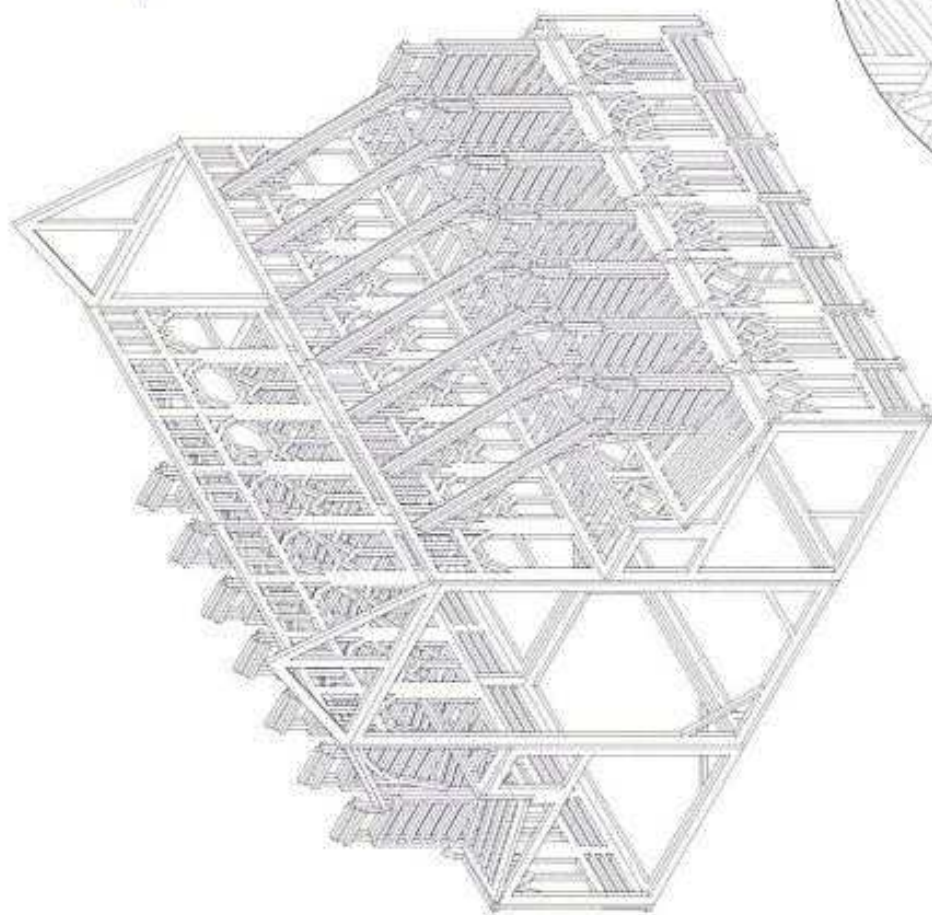
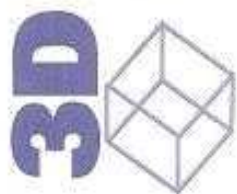

21

22

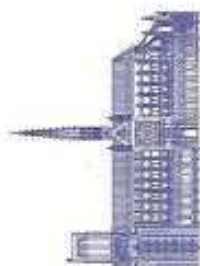

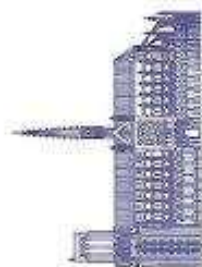
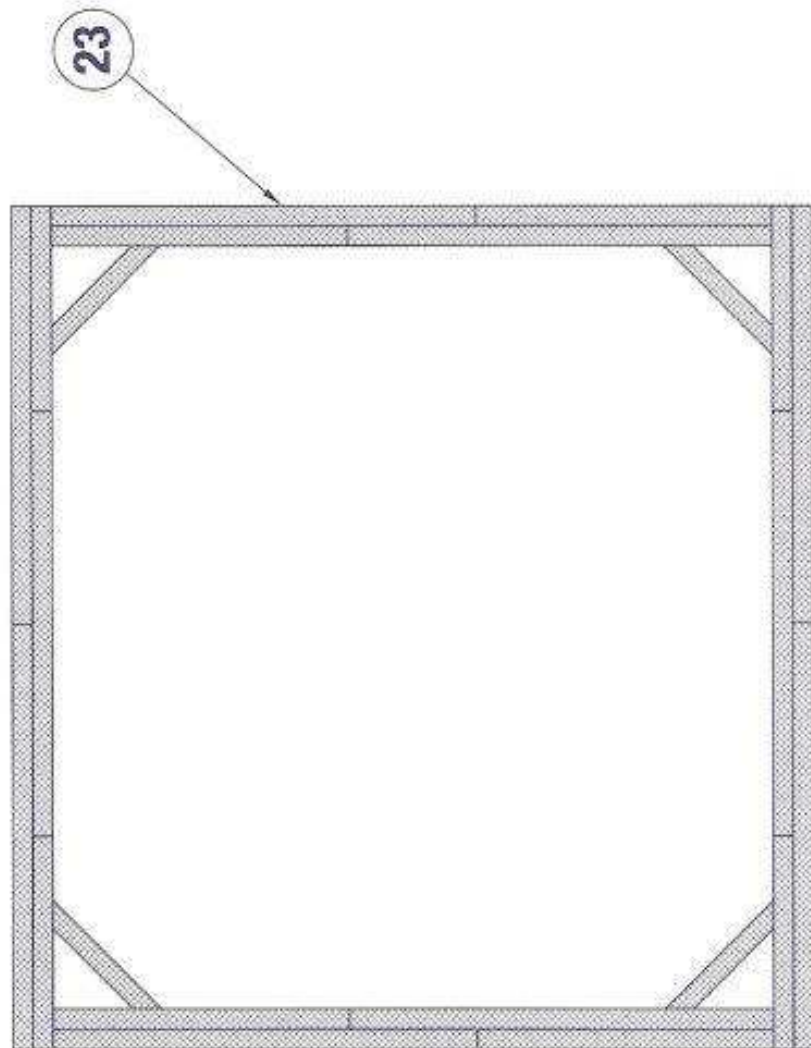

2x 24

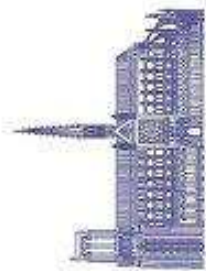
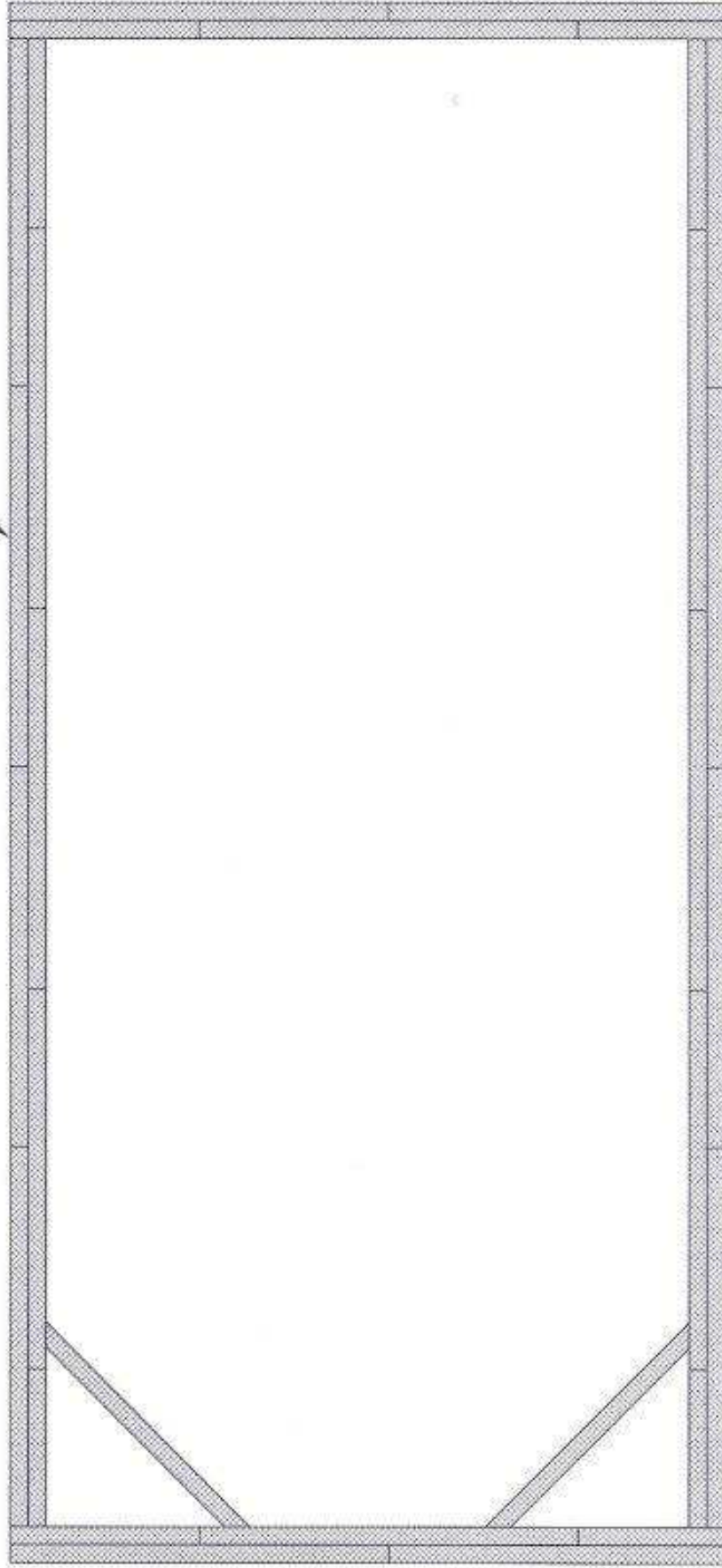

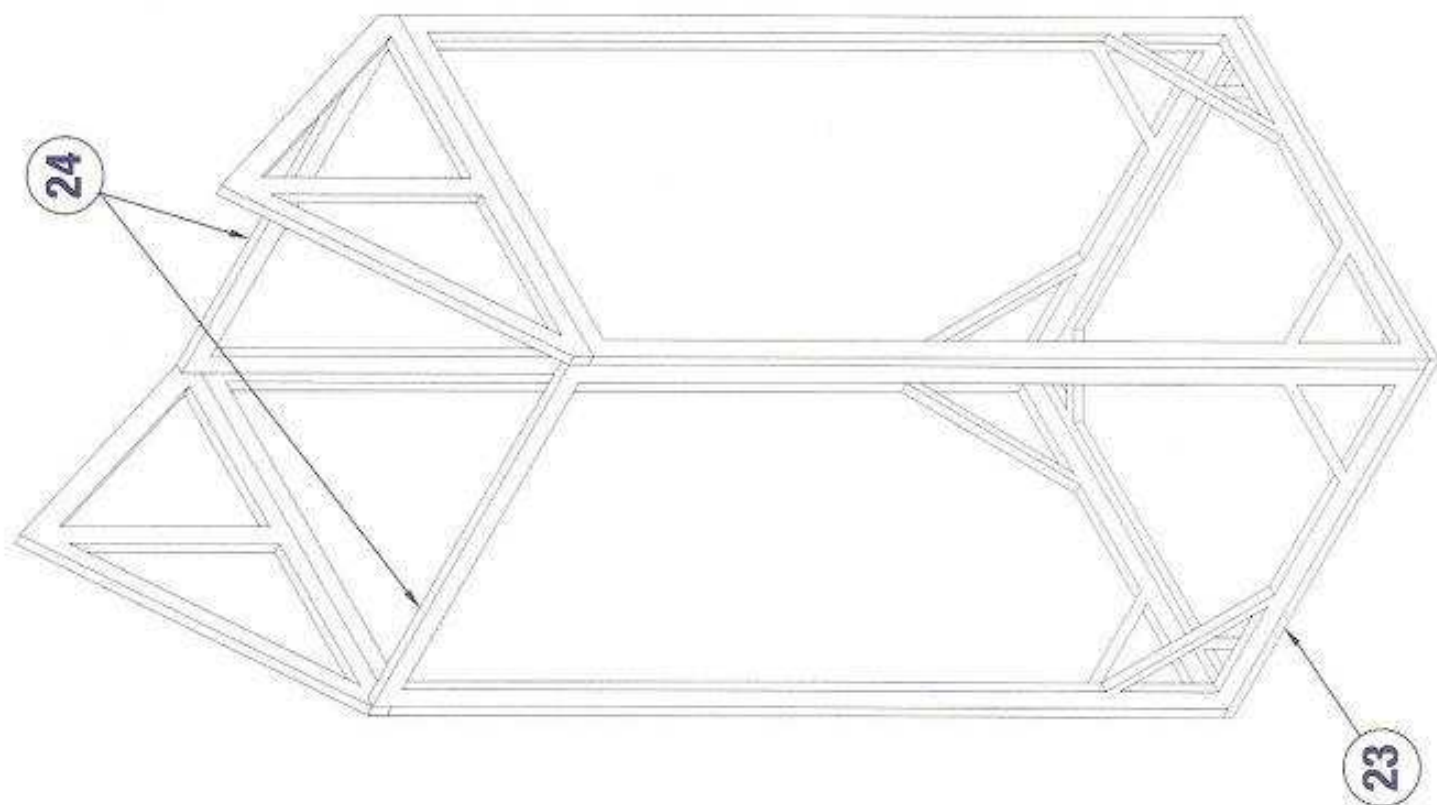

3D

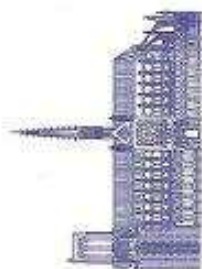
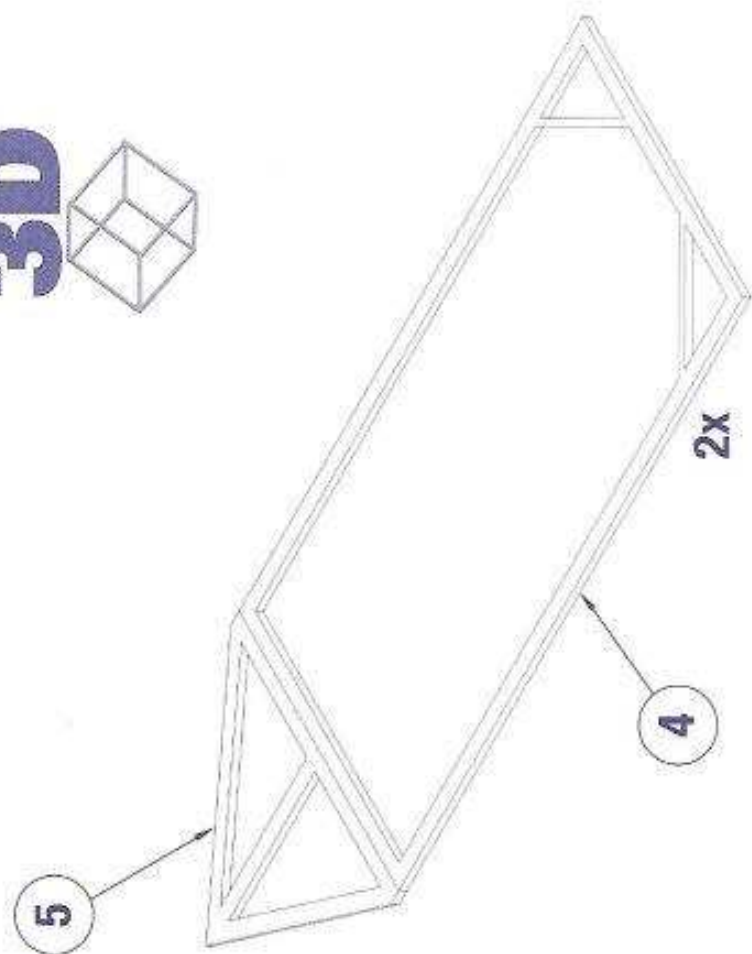

2x 25

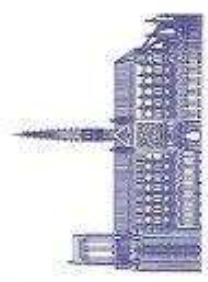
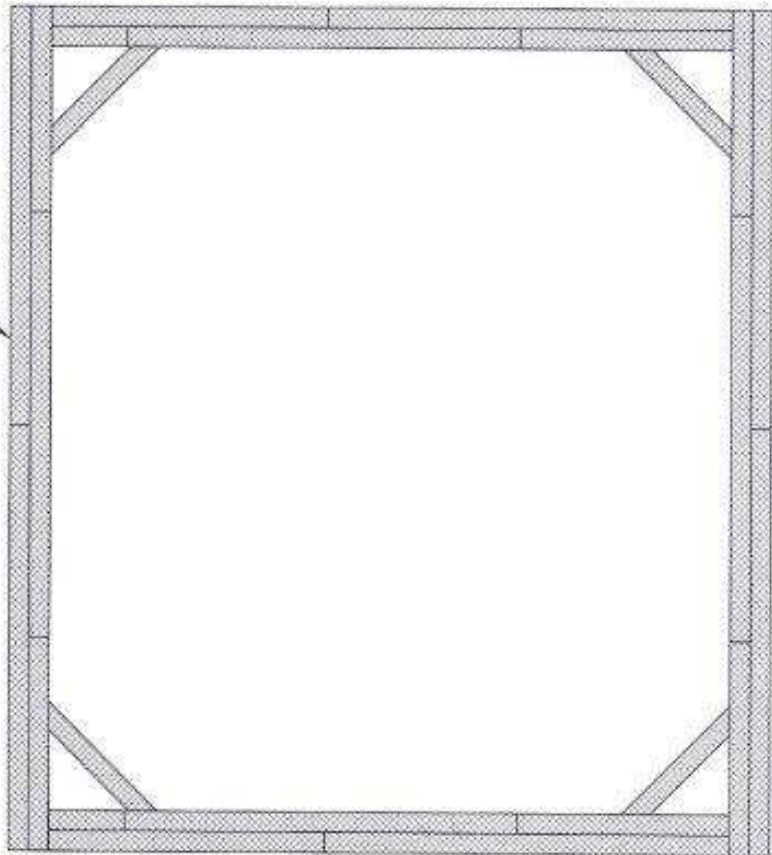

2x 26

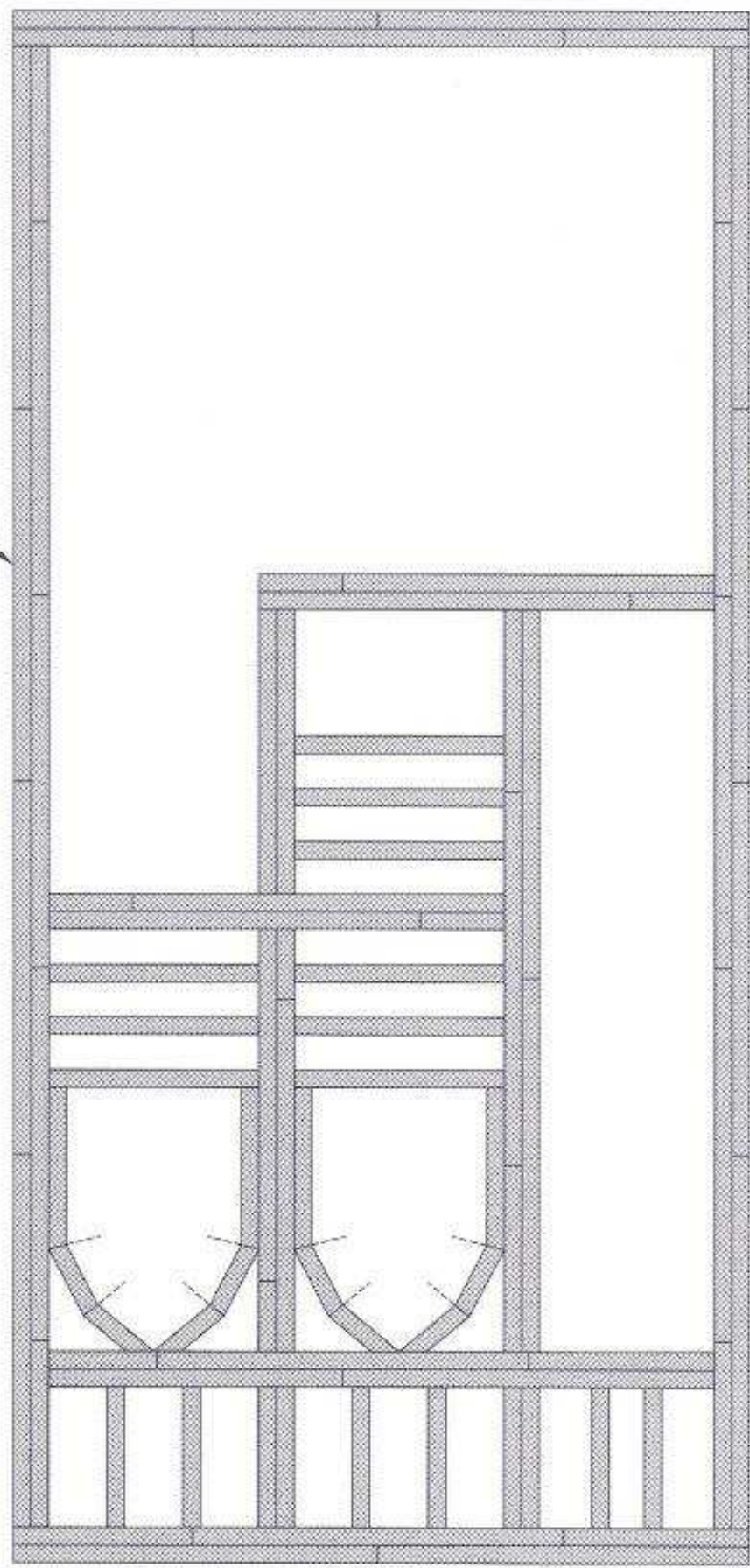

2x 27

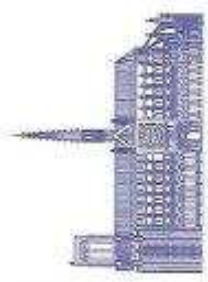
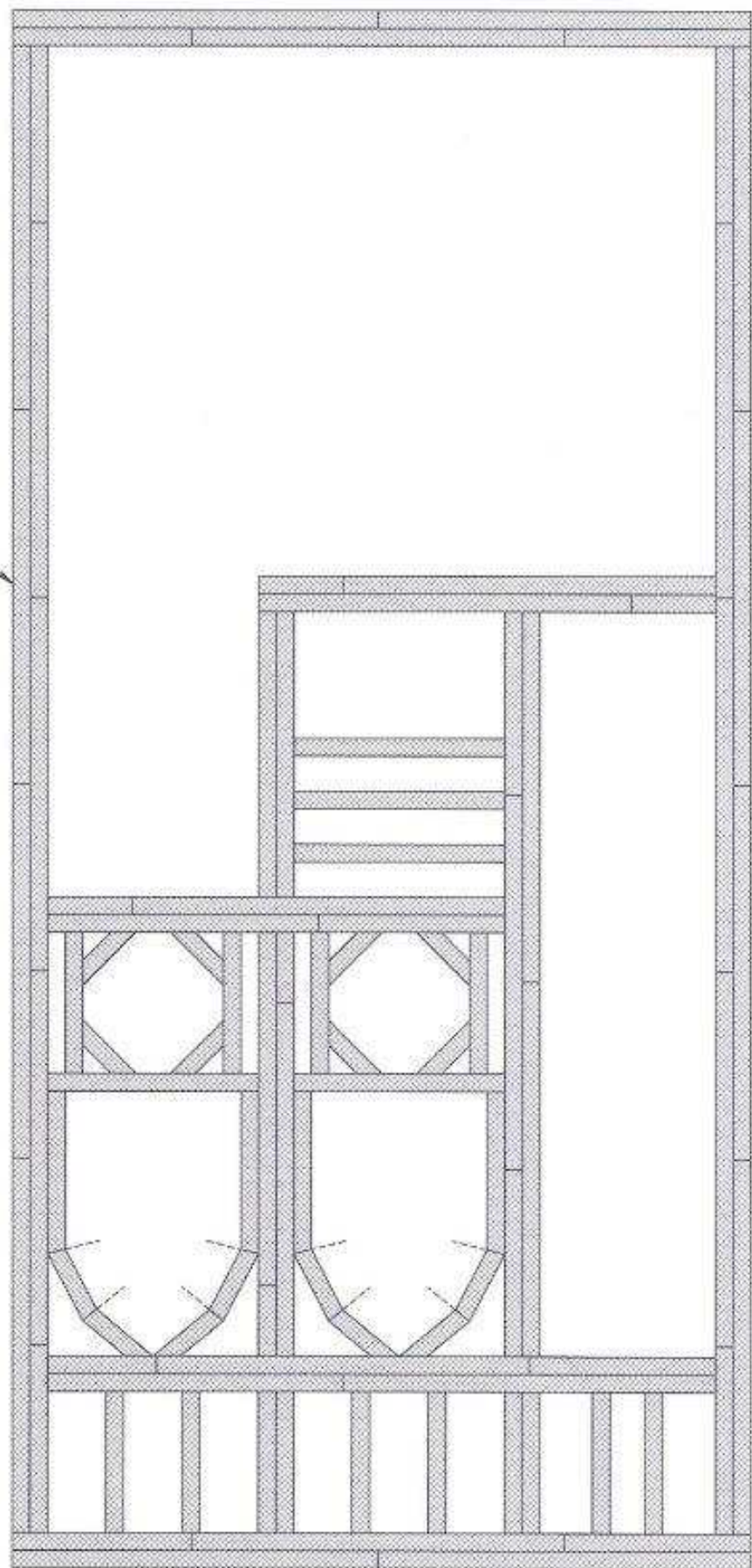

2x 28

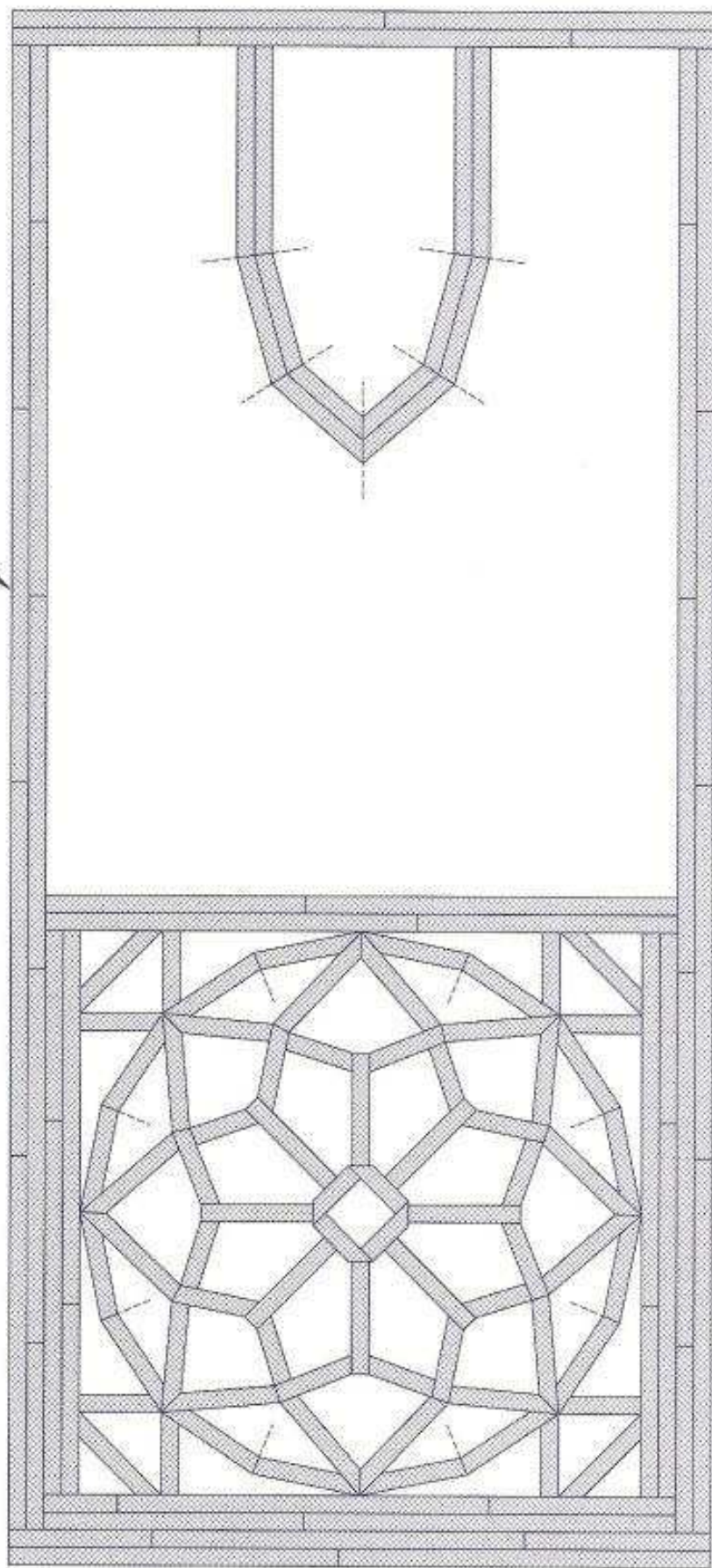

© 2006 Bejeux, Inc.

[www.matchitecture.com](http://www.matchitecture.com)

MATCHITECTURE

25 #05

2x 29

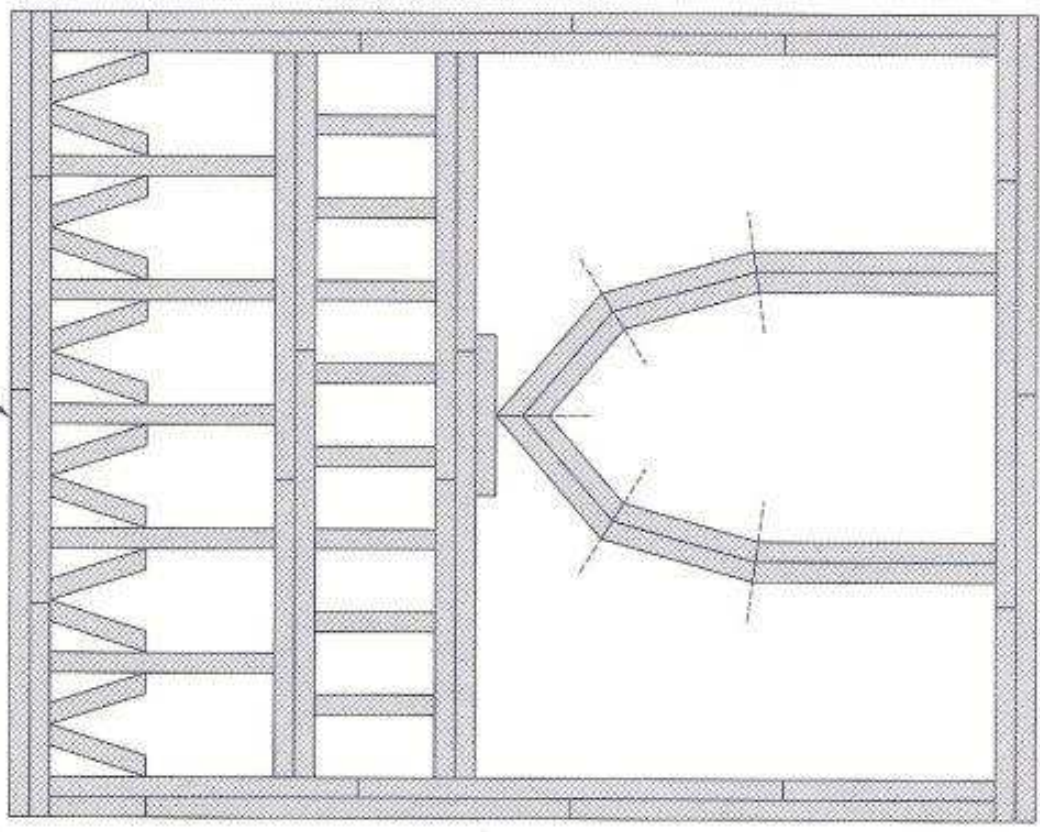

2x 30

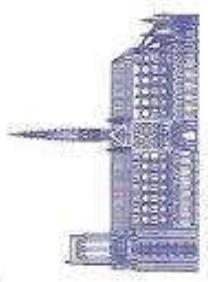
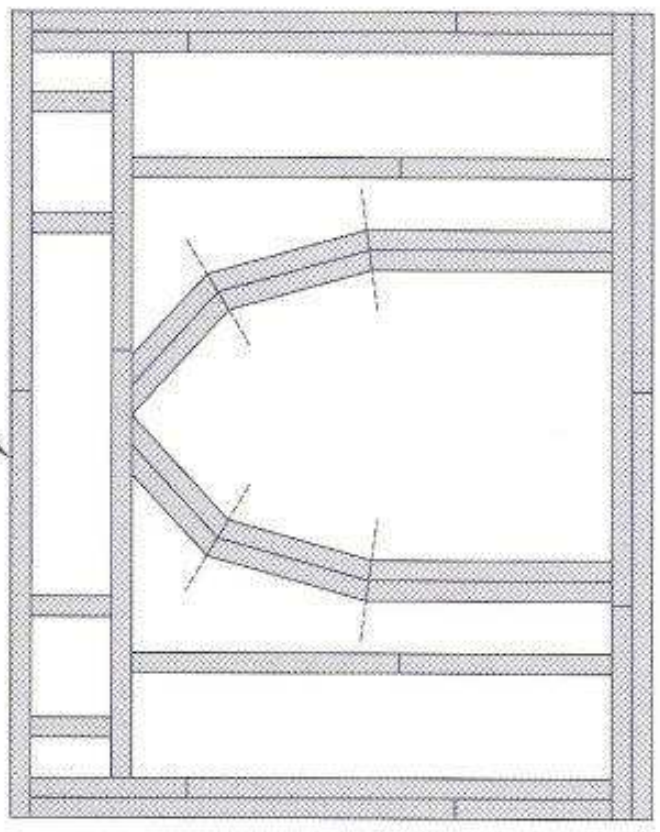

© 2006 Bojeux Inc.

www.matchitecture.com

MATCHITECTURE

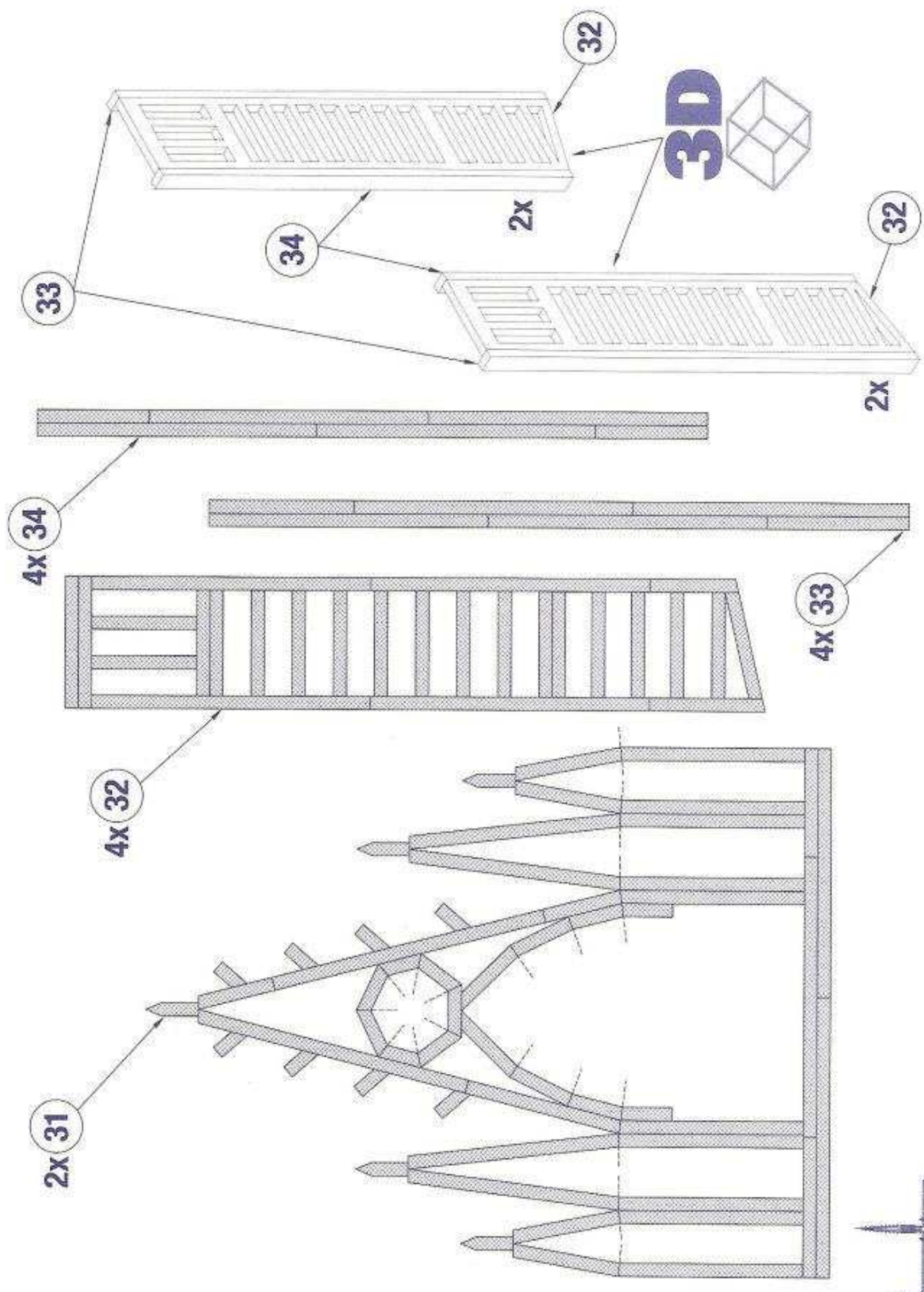

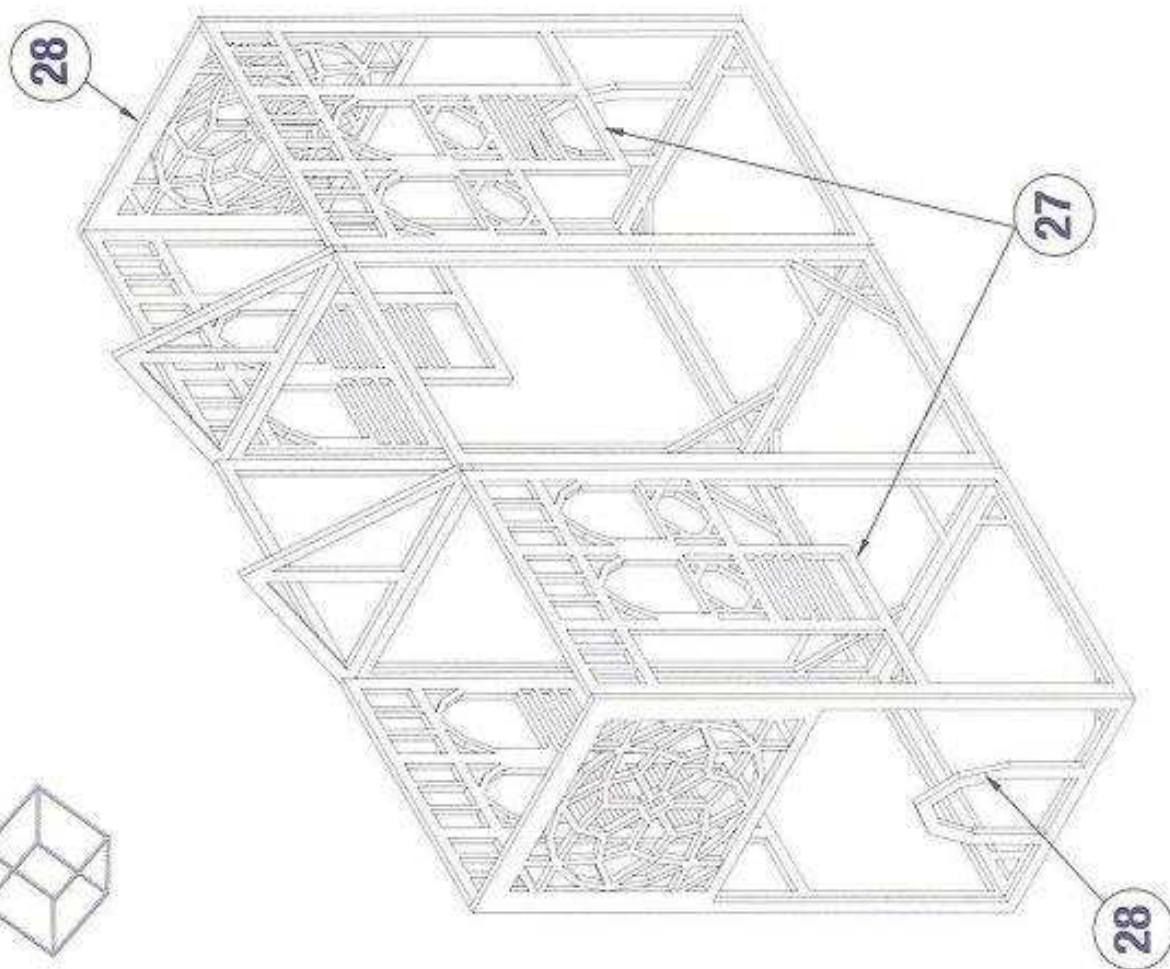
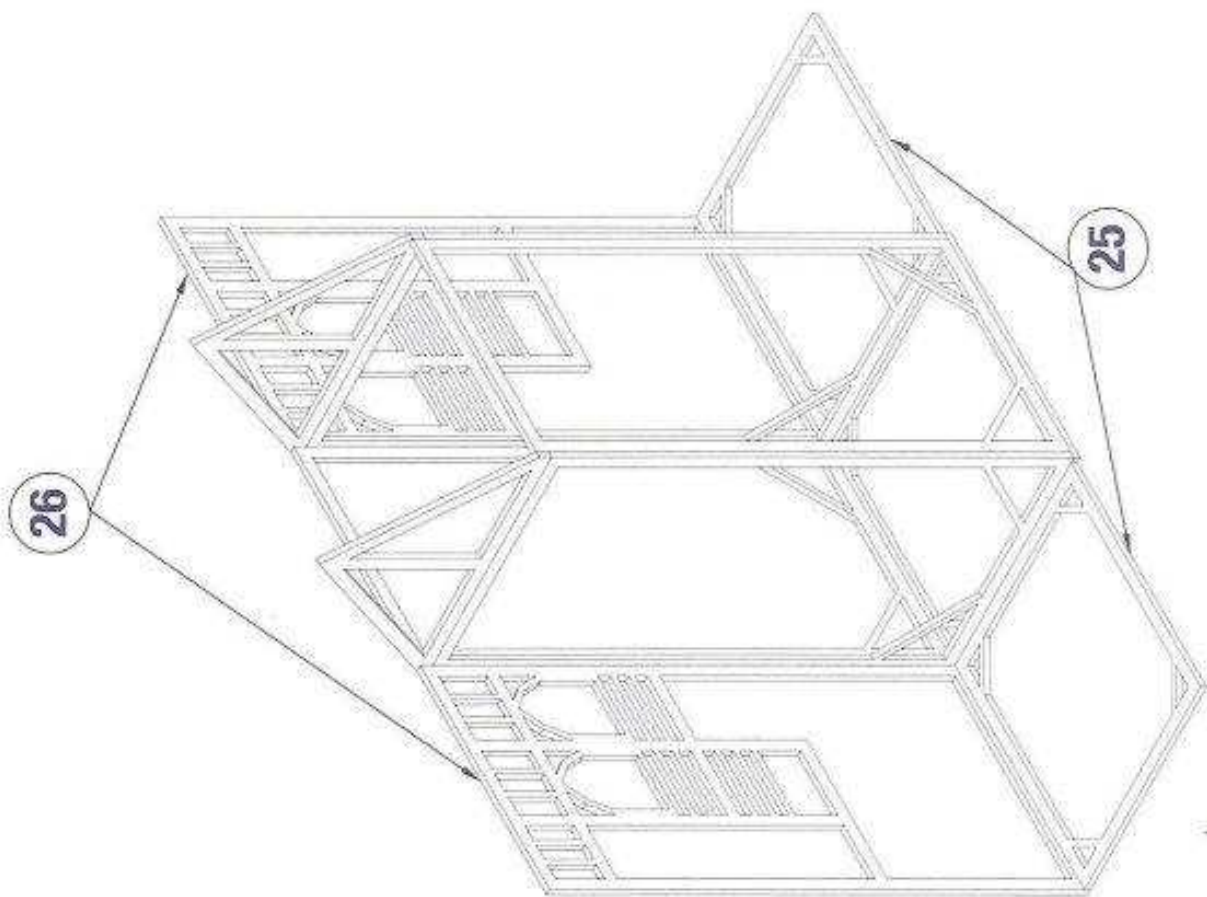
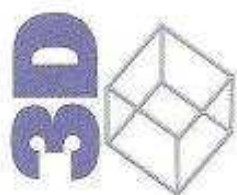

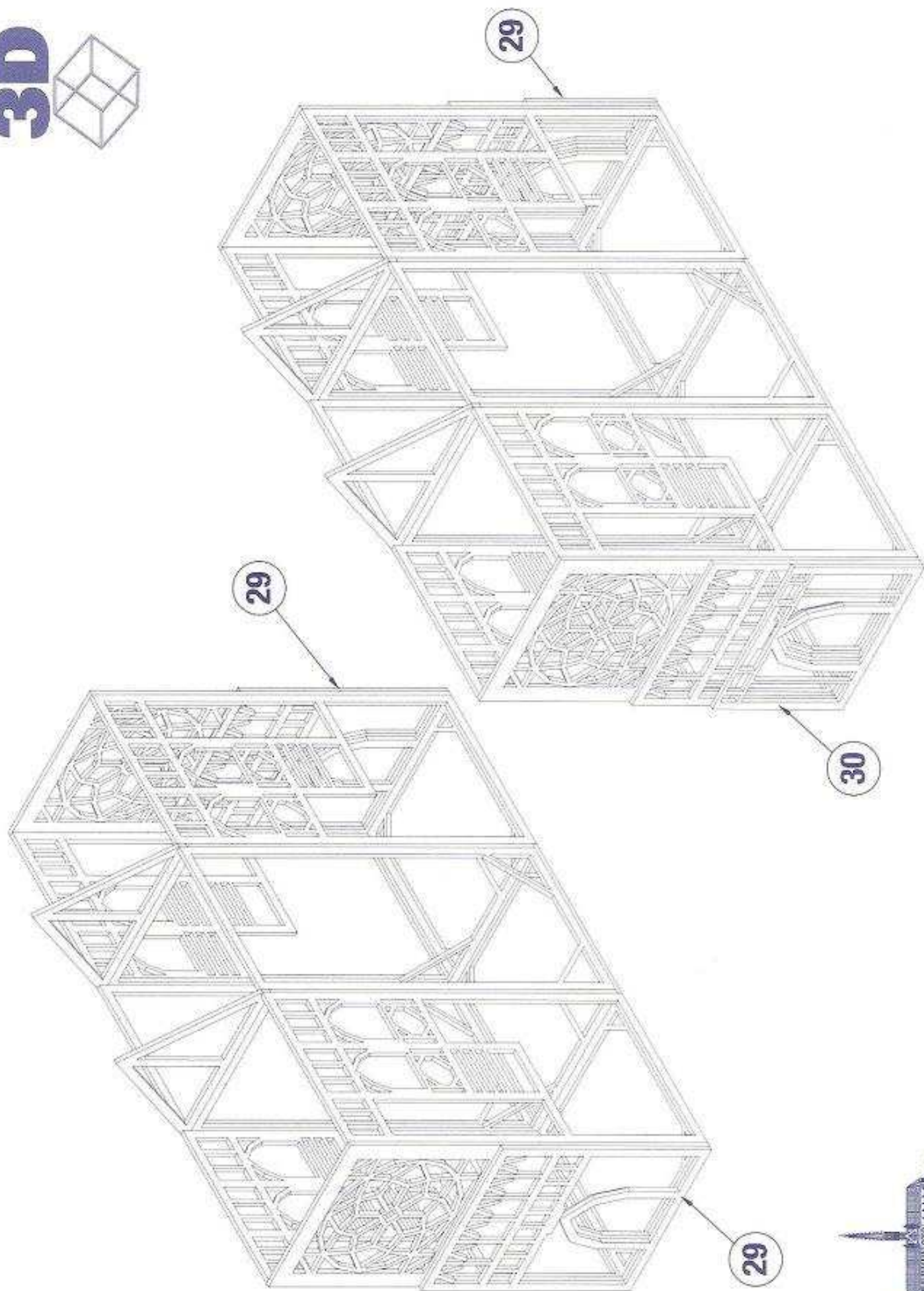
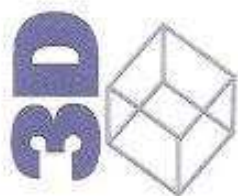

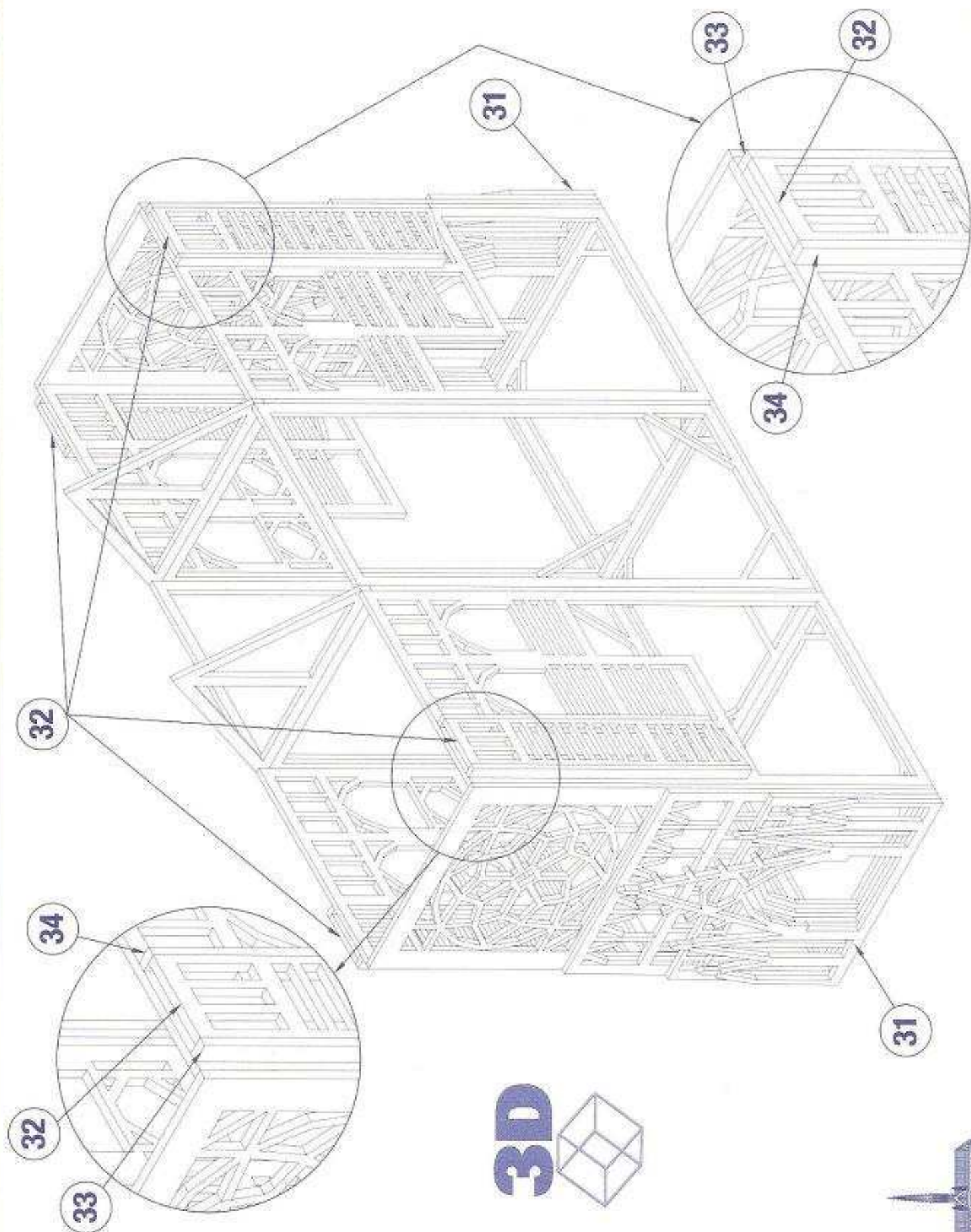

**3D** 

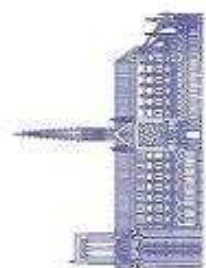

© 2006 Bjoerk Inc.

**3D**

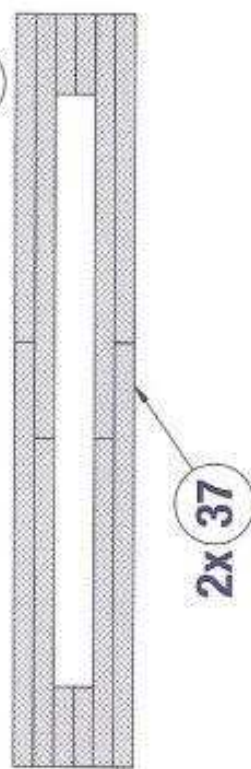
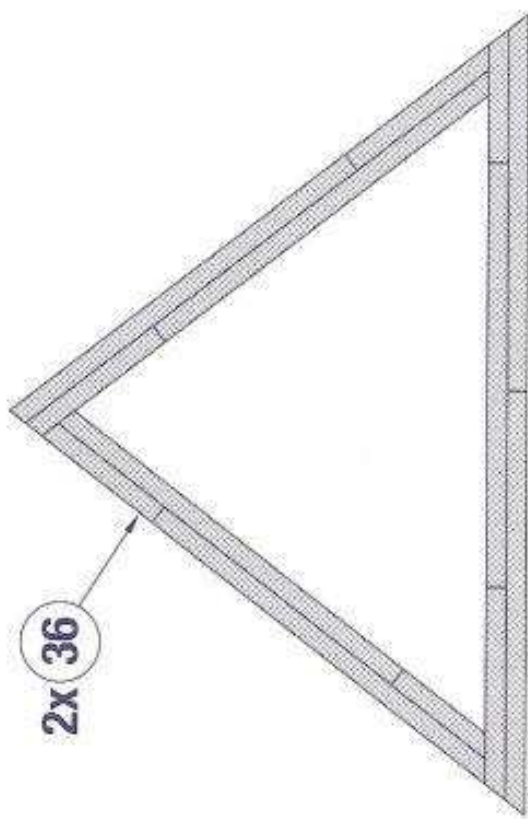
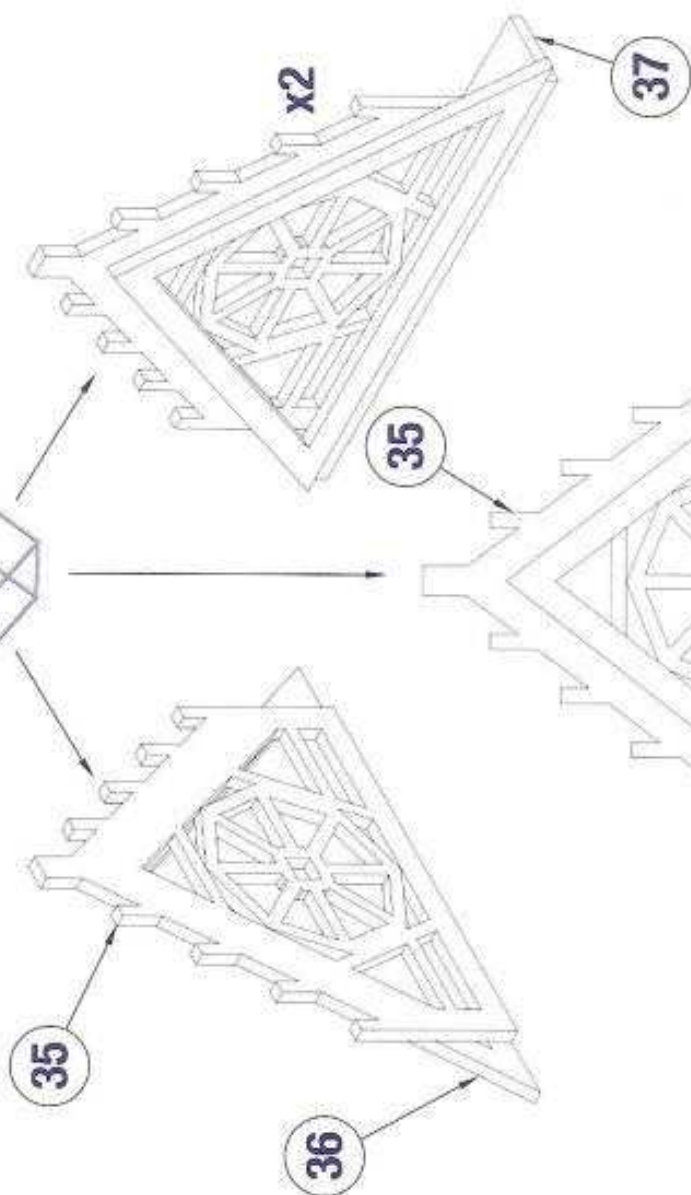
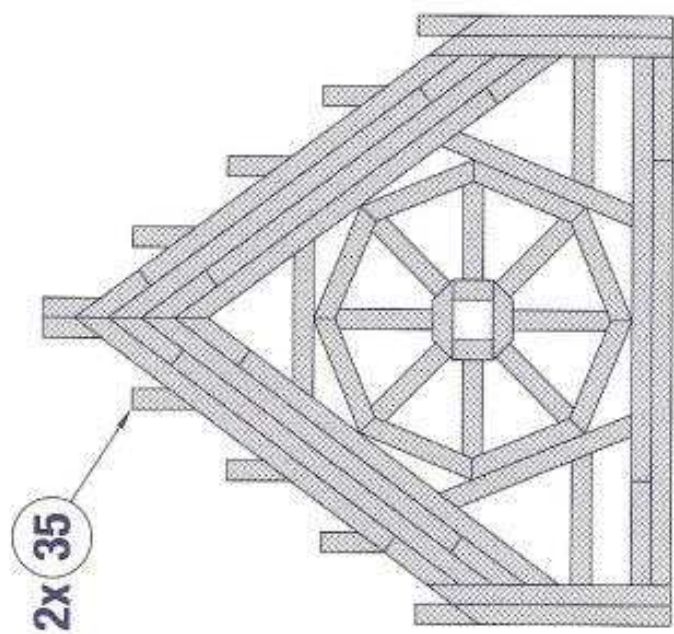

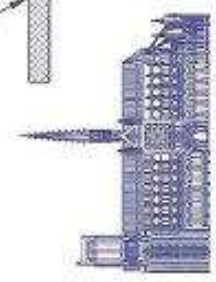
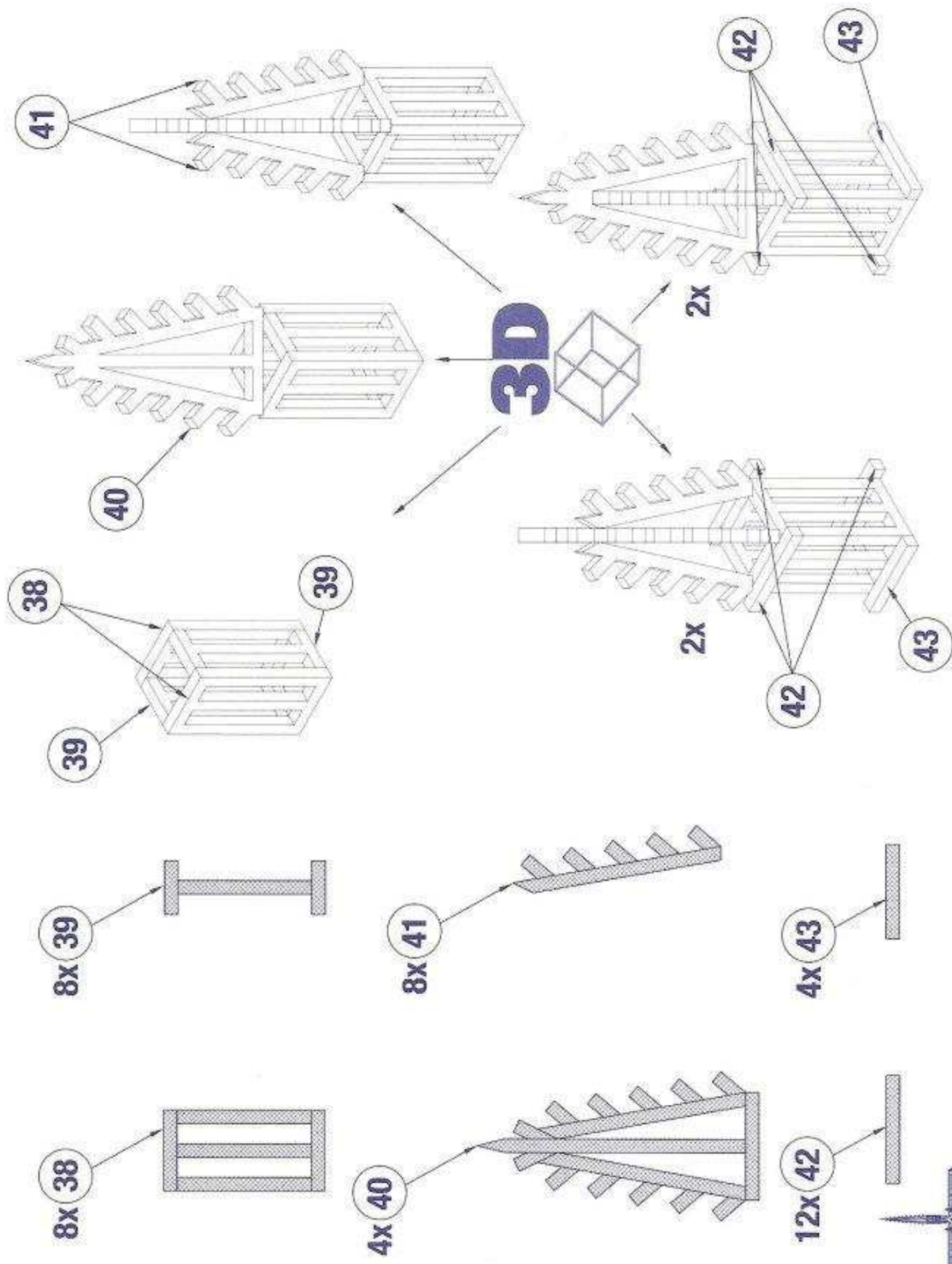

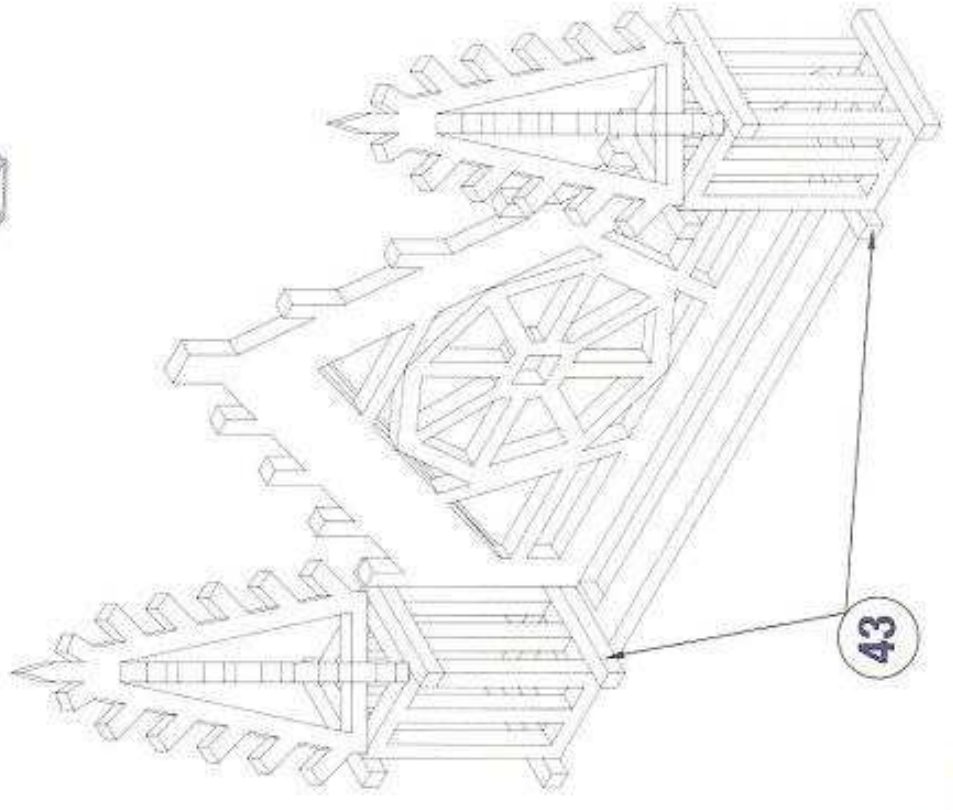
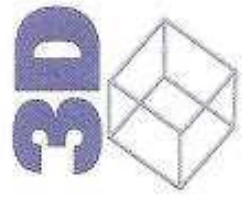
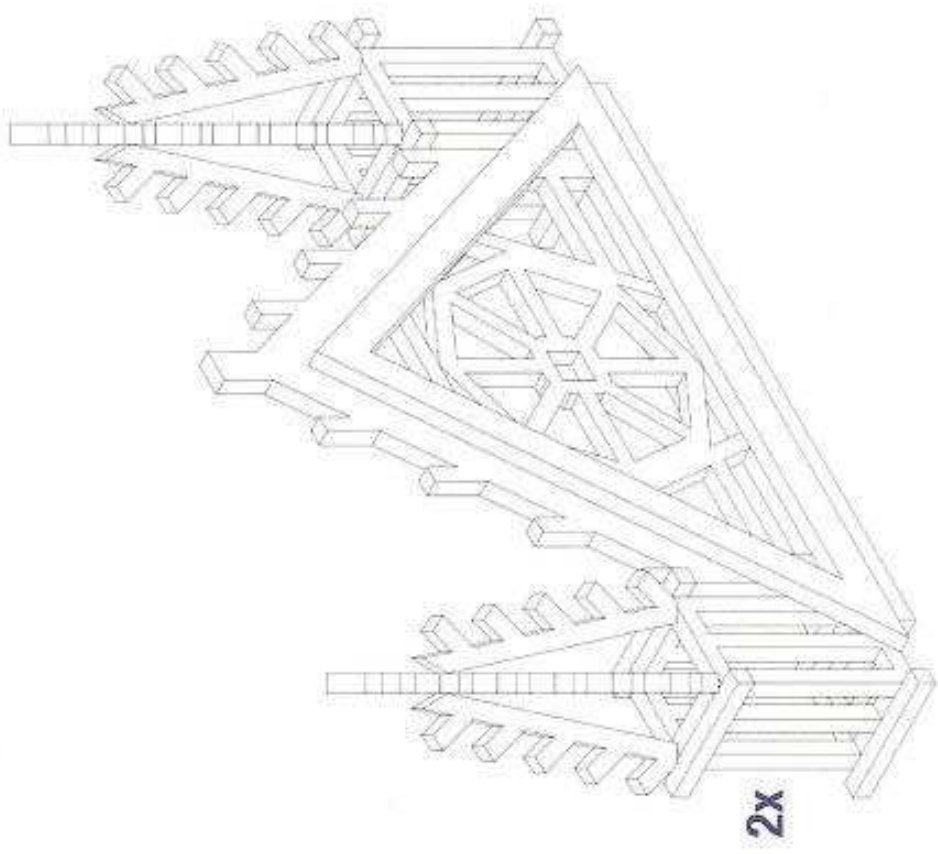

43

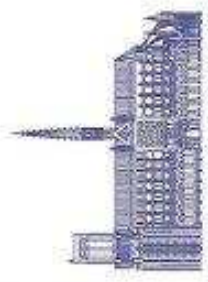

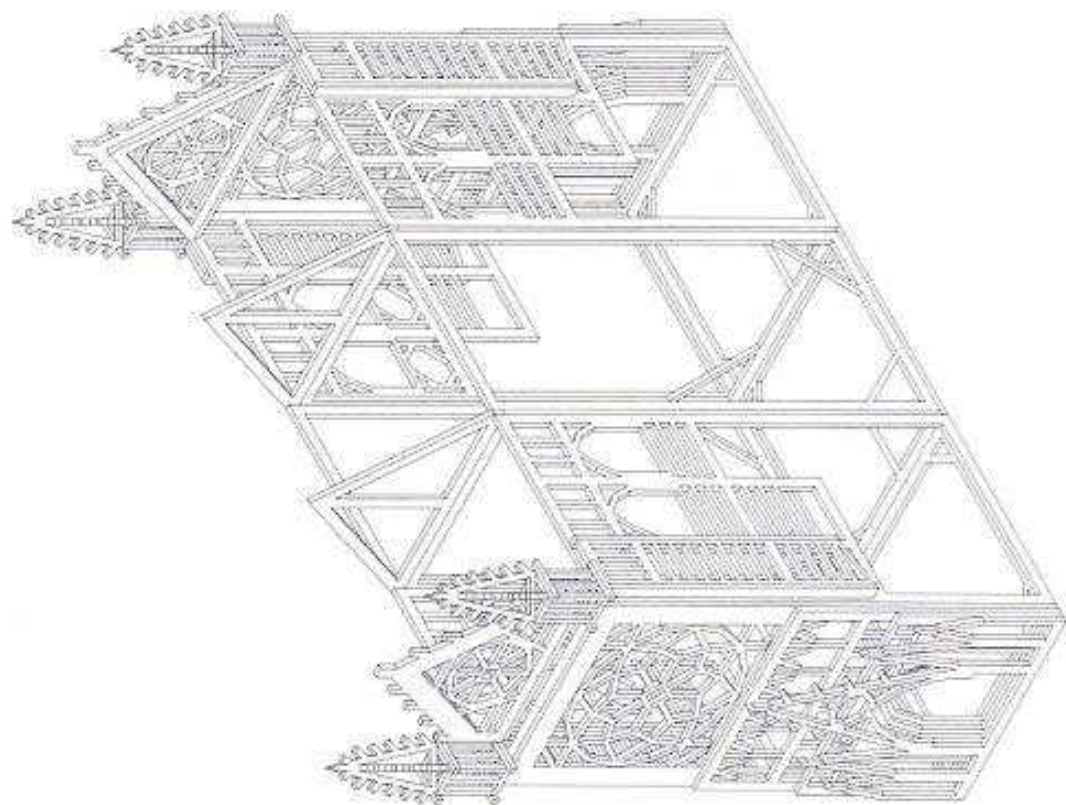
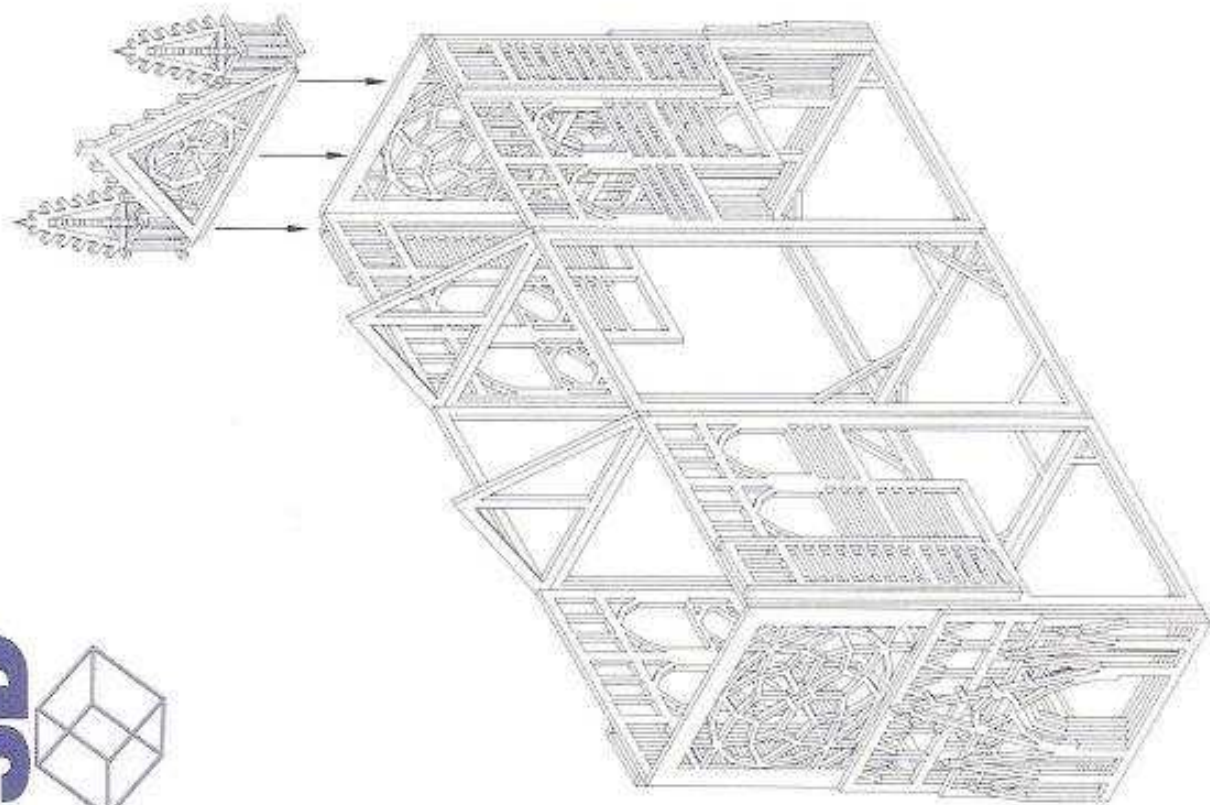
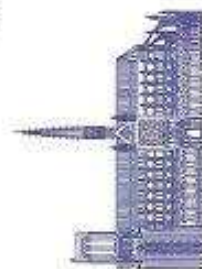
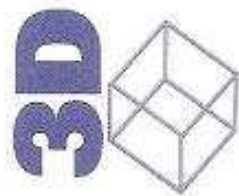

44

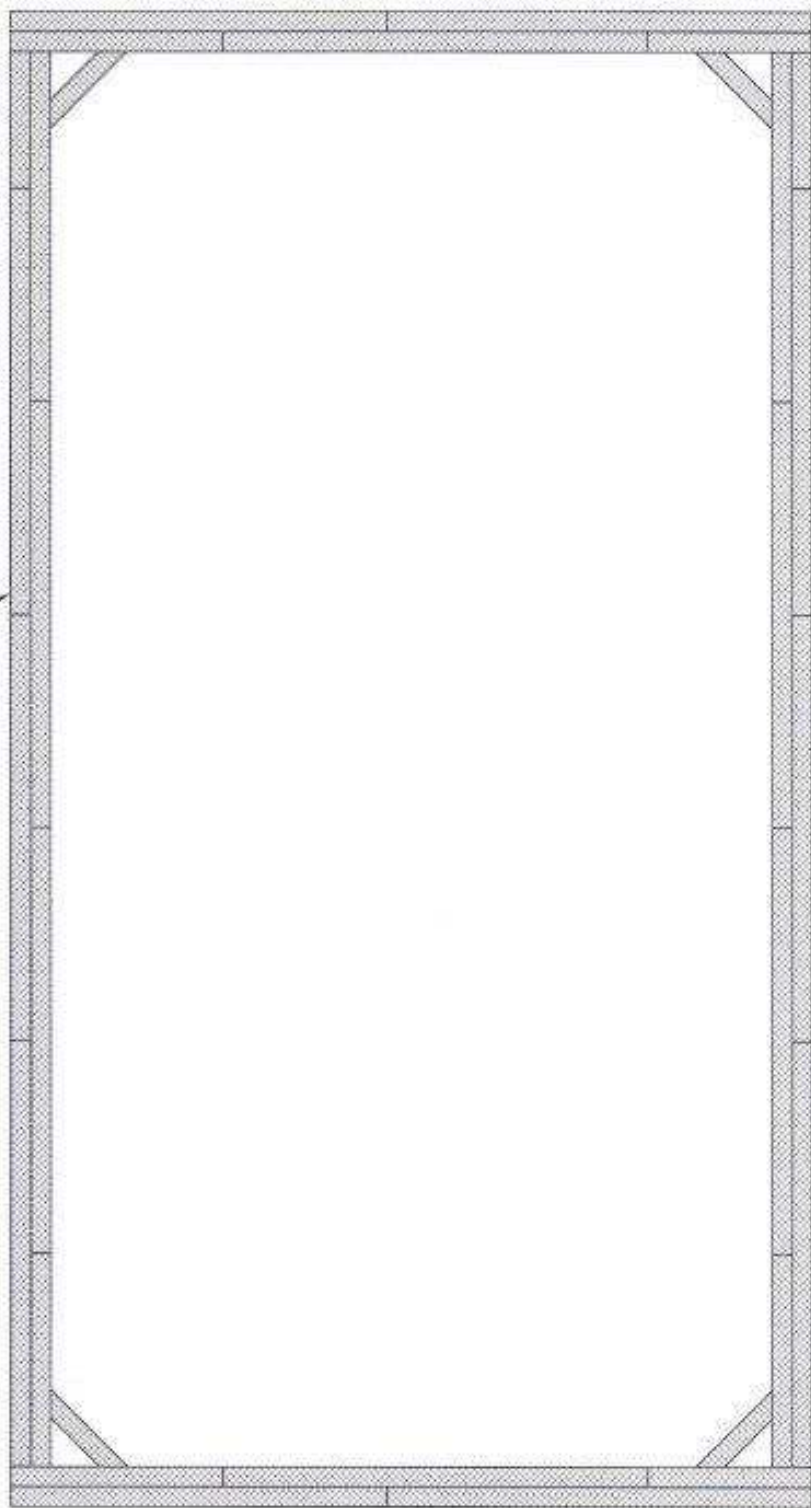

2x 45

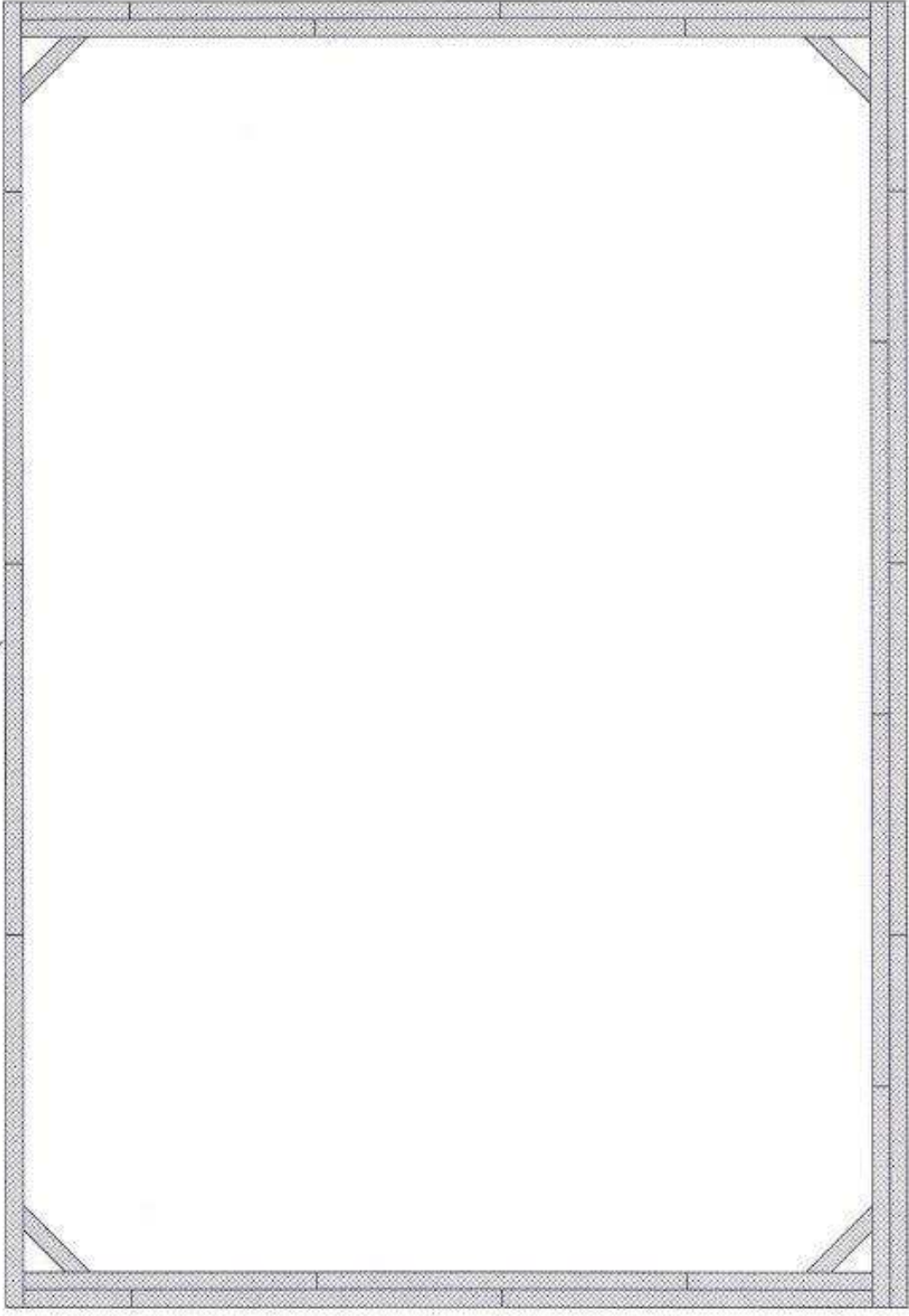

© 2006 Bajoux Inc.

[www.matchitecture.com](http://www.matchitecture.com)

MATCHITECTURE

**3D**

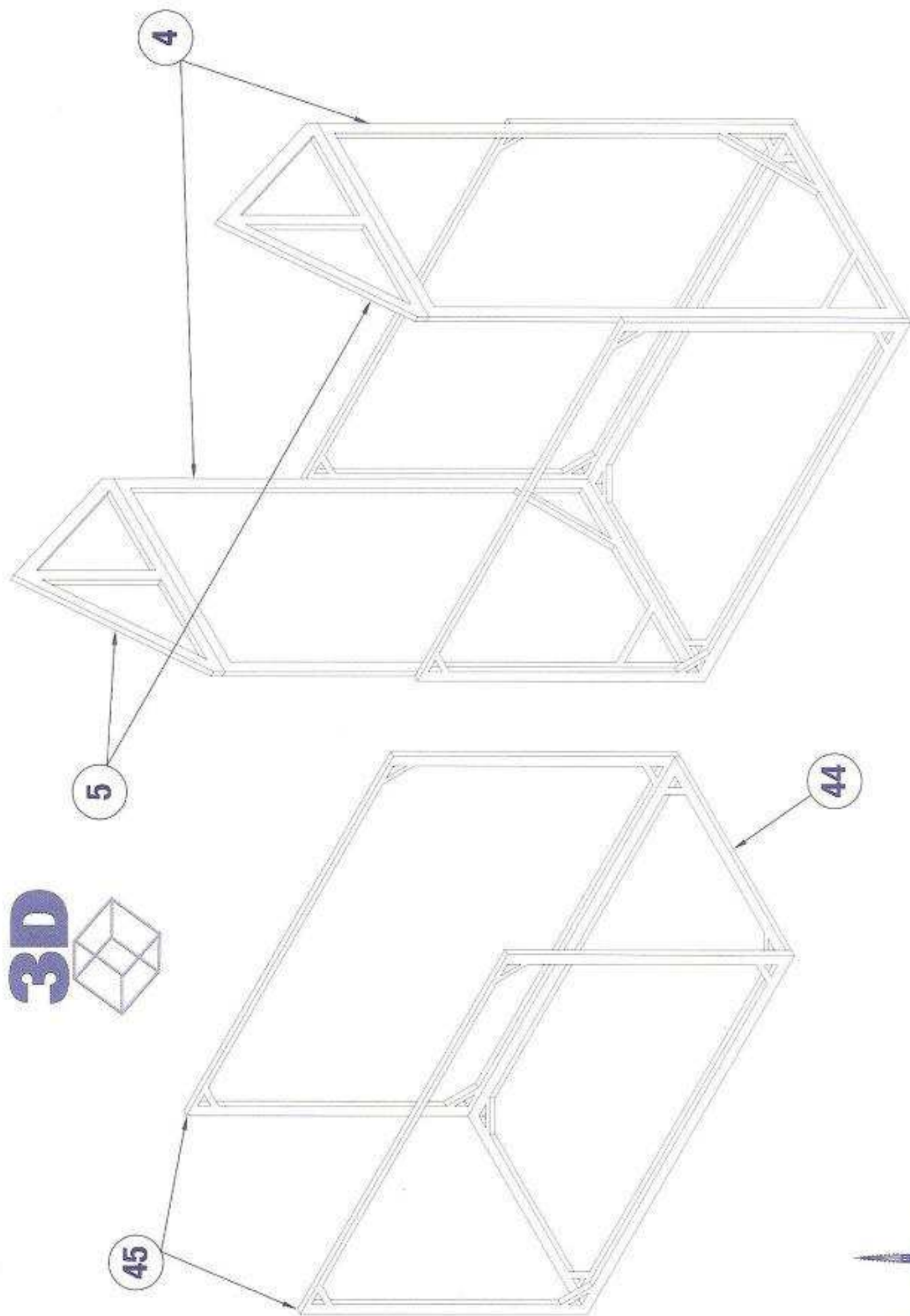

2x 46

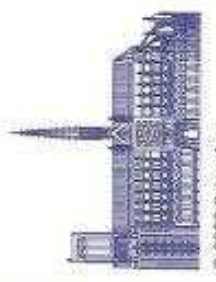
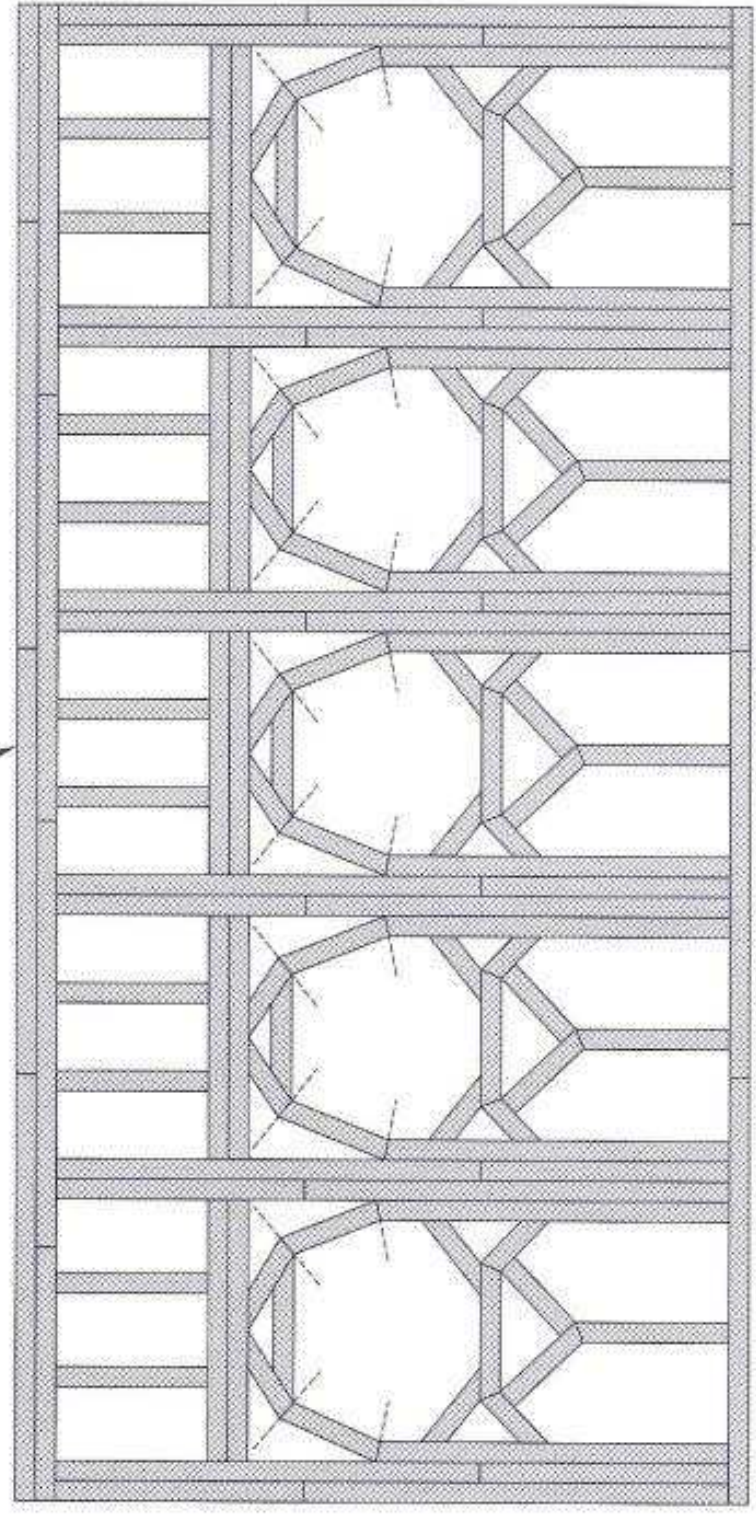

2x 48

4x 47

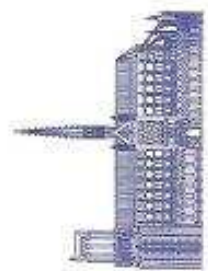
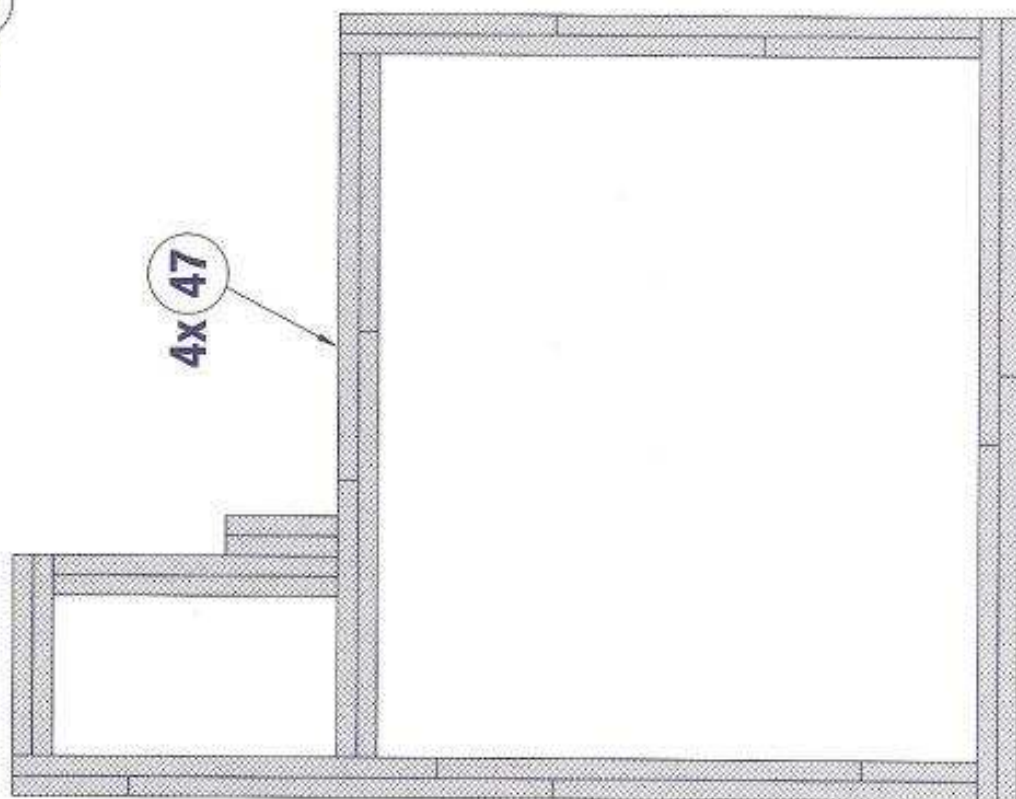
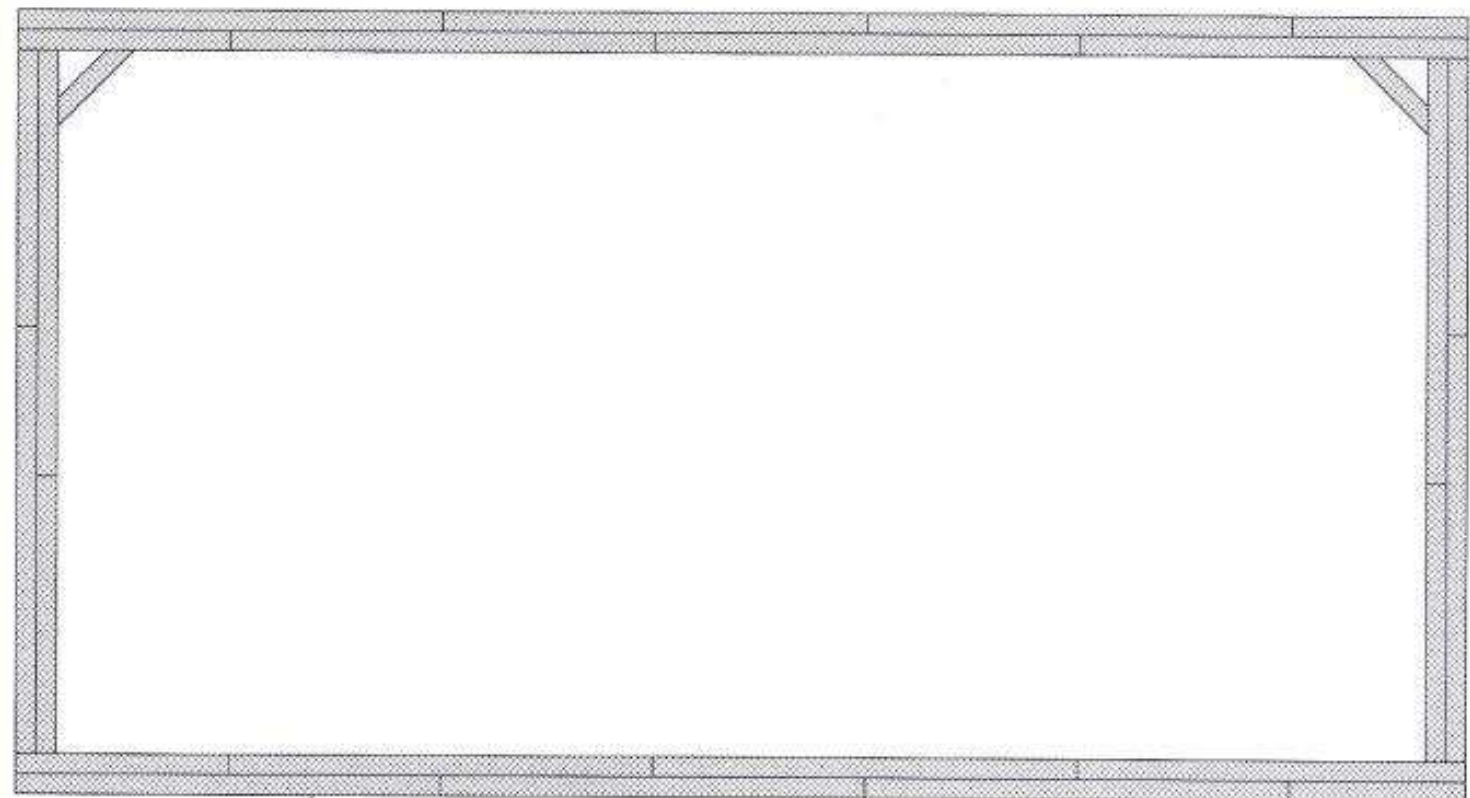

© 2006 Boykin Inc.

www.matchitecture.com

MATCHITECTURE

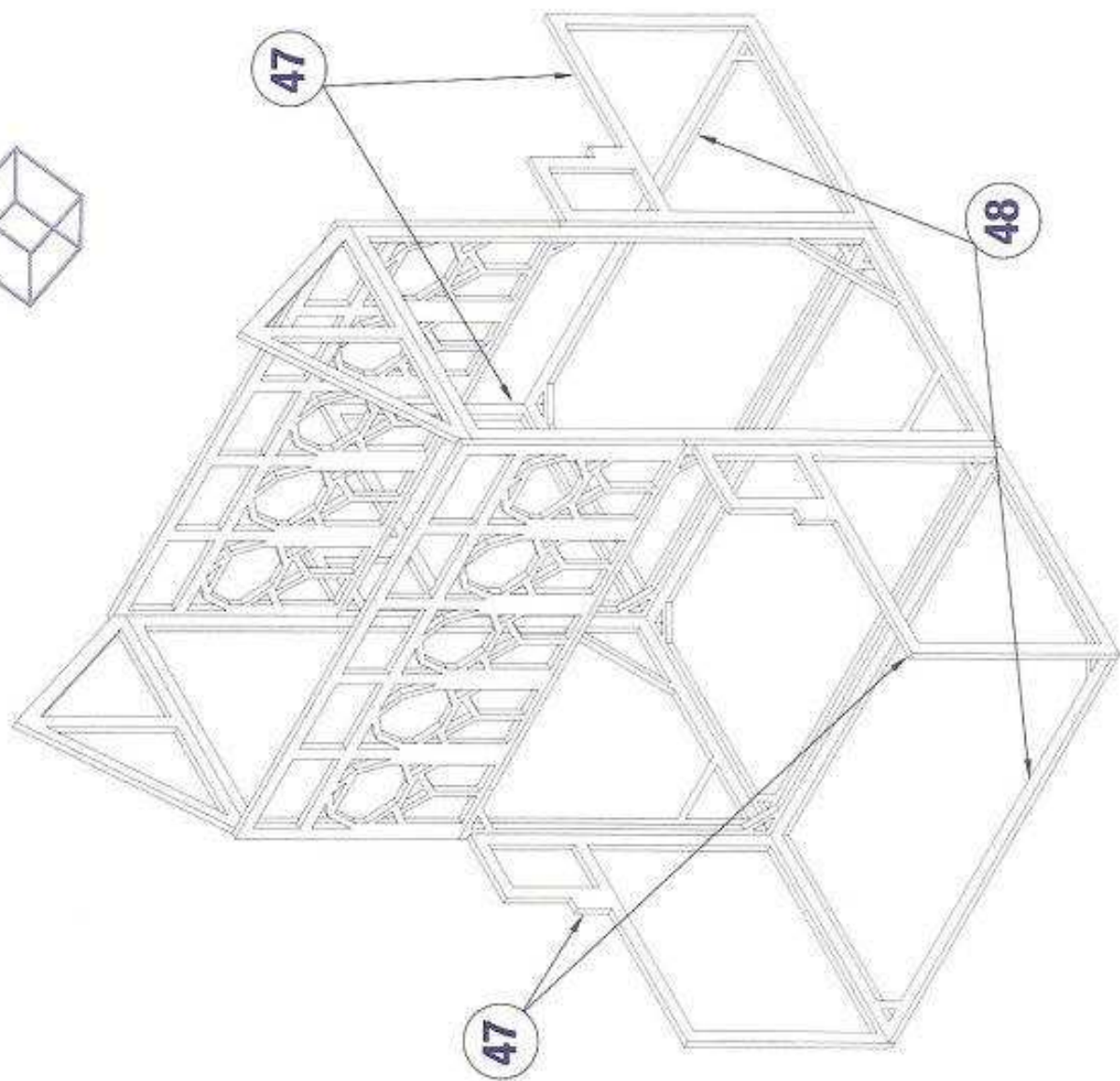
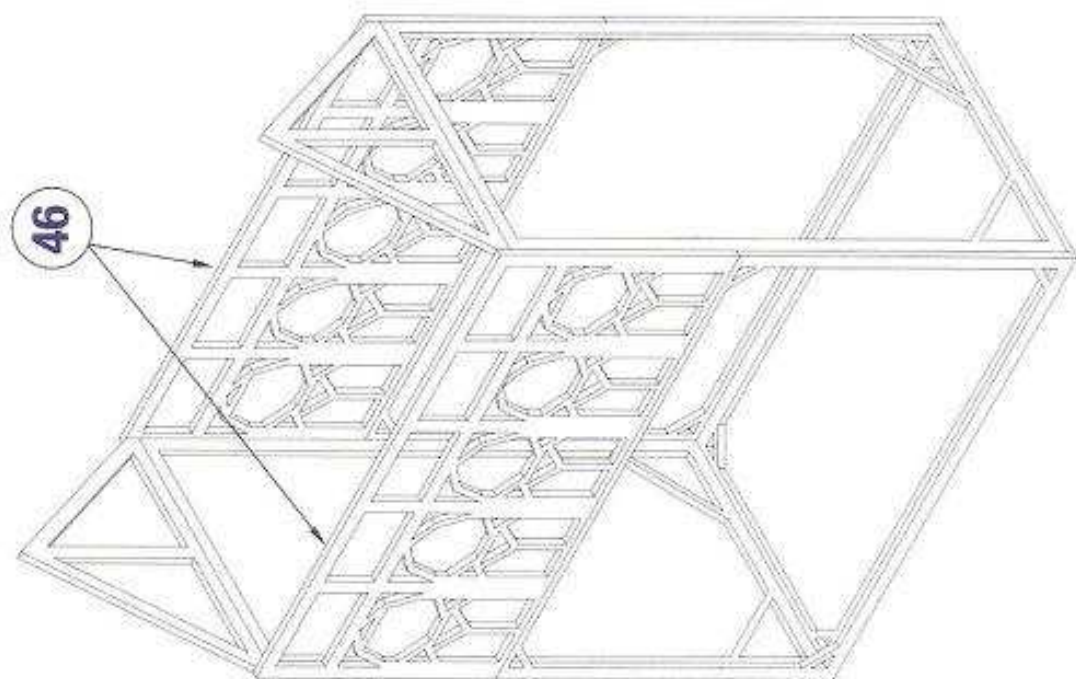

2x 49

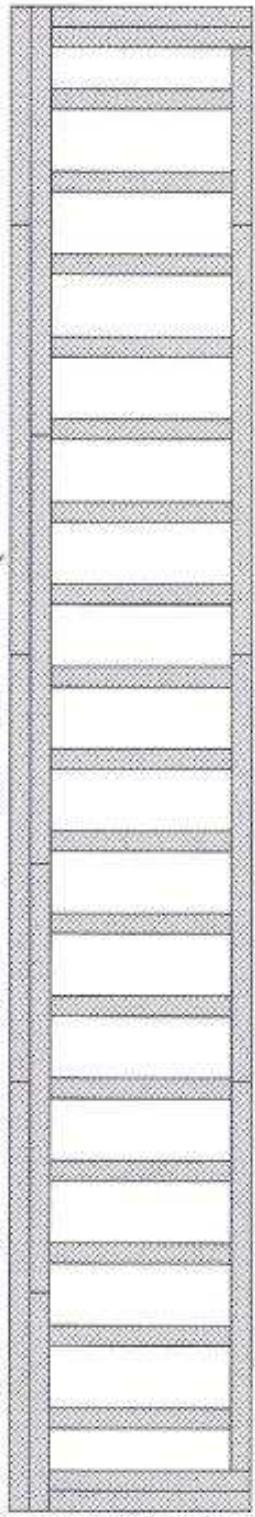

2x 50

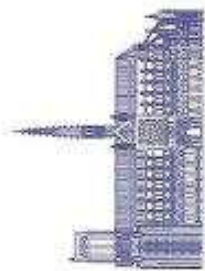
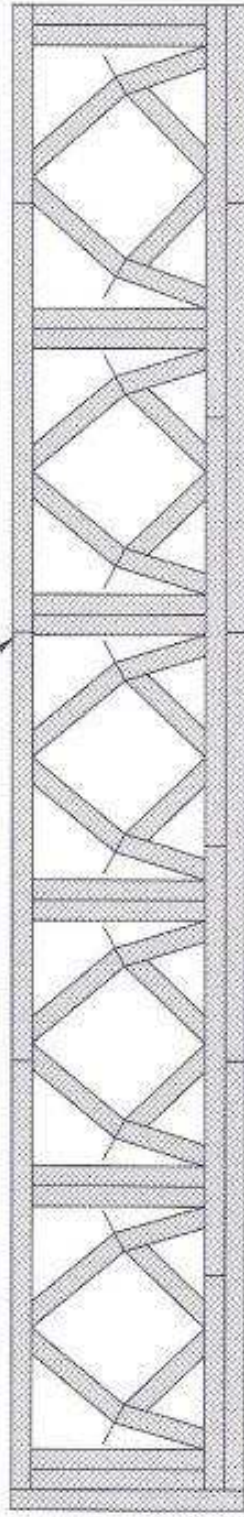

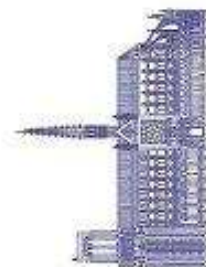
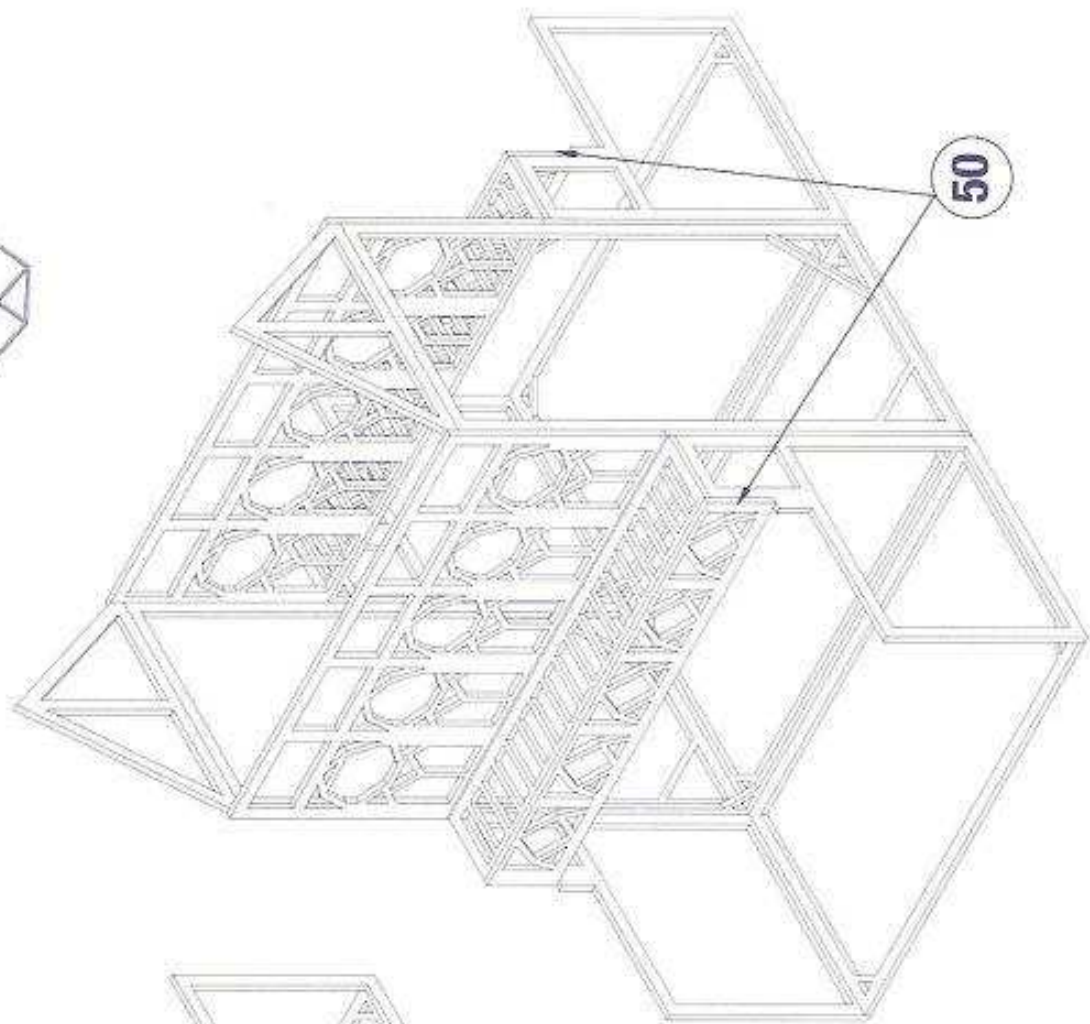
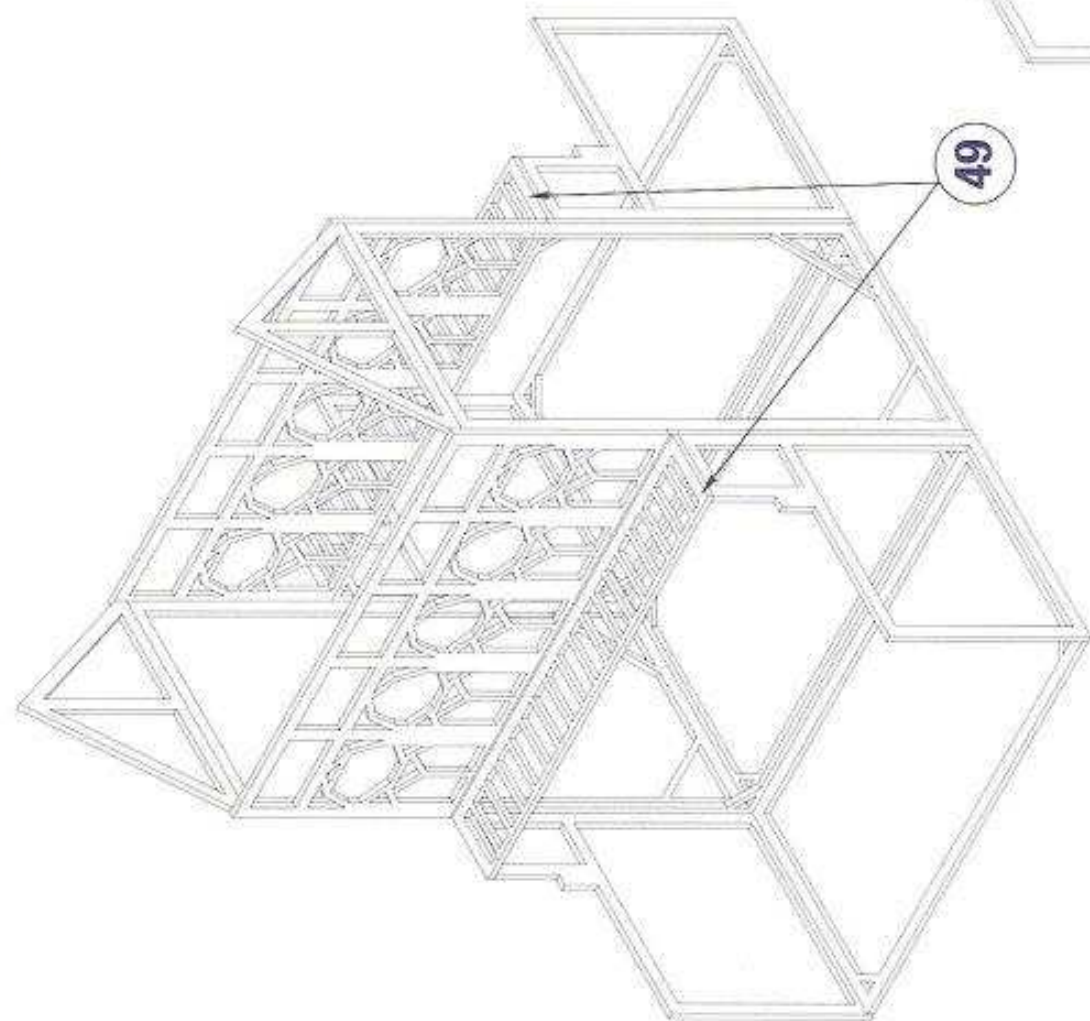
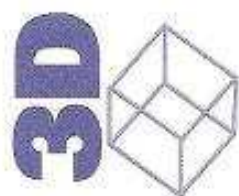

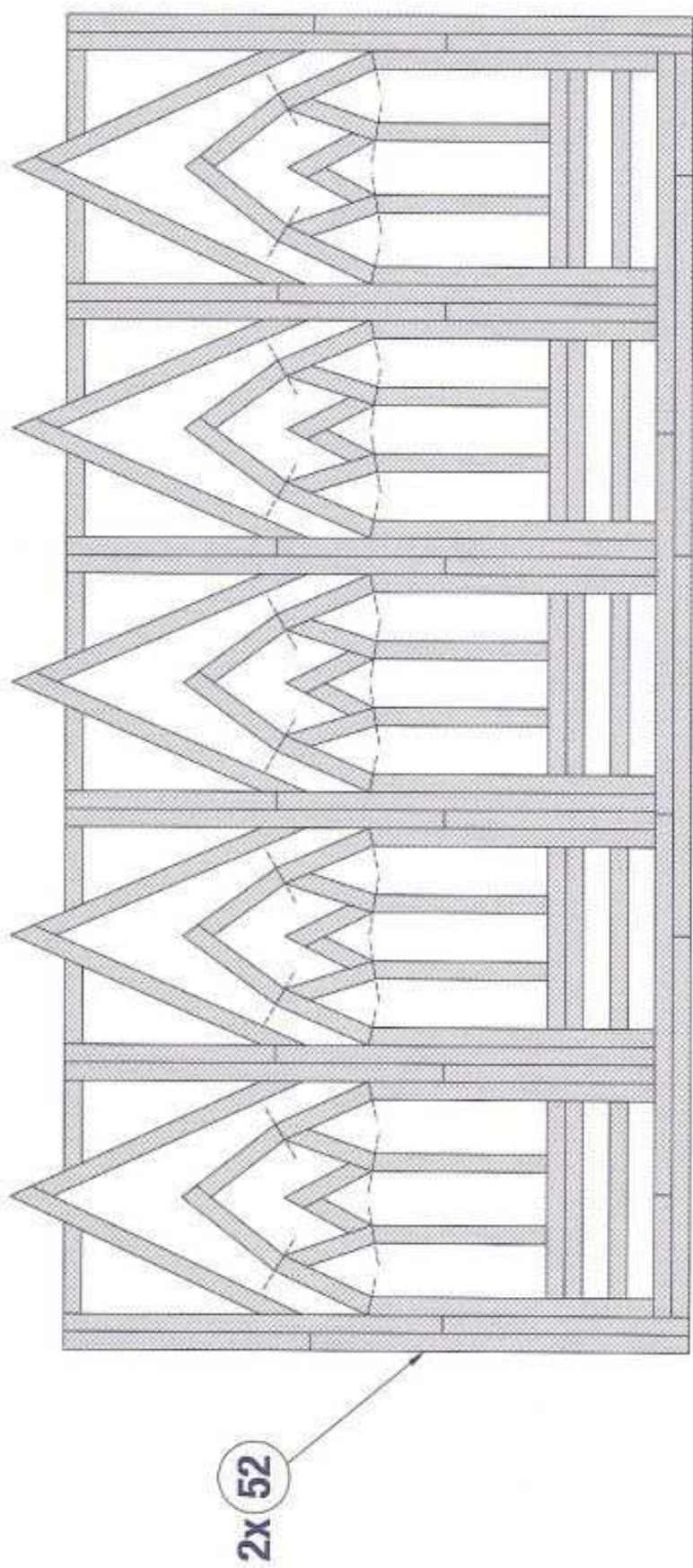
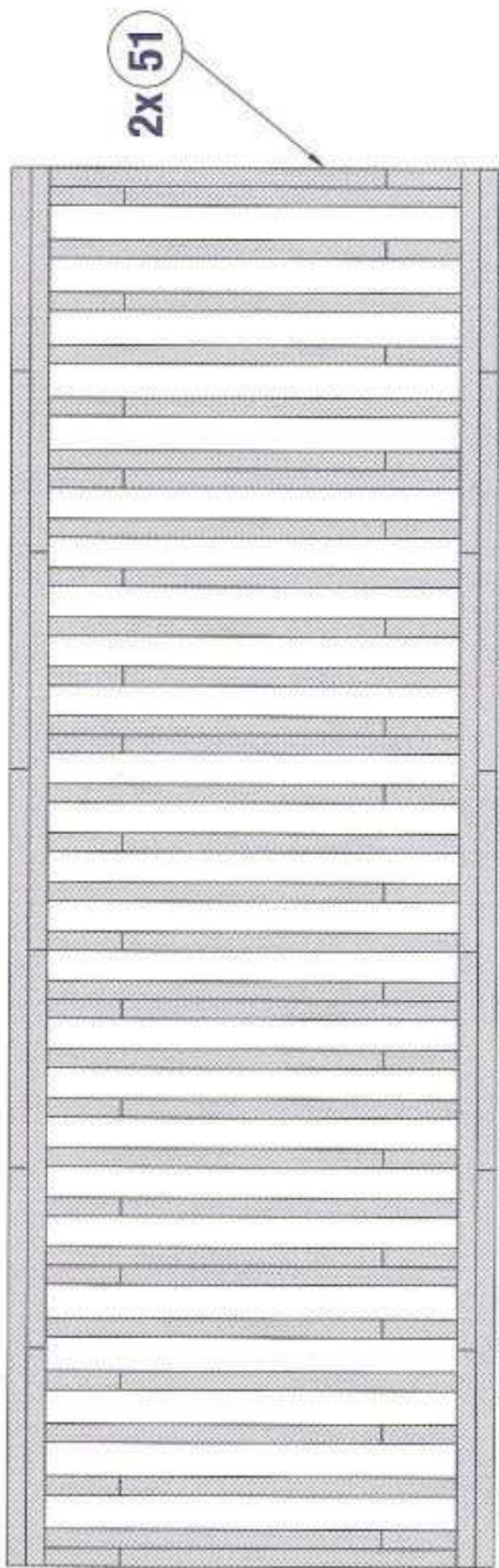

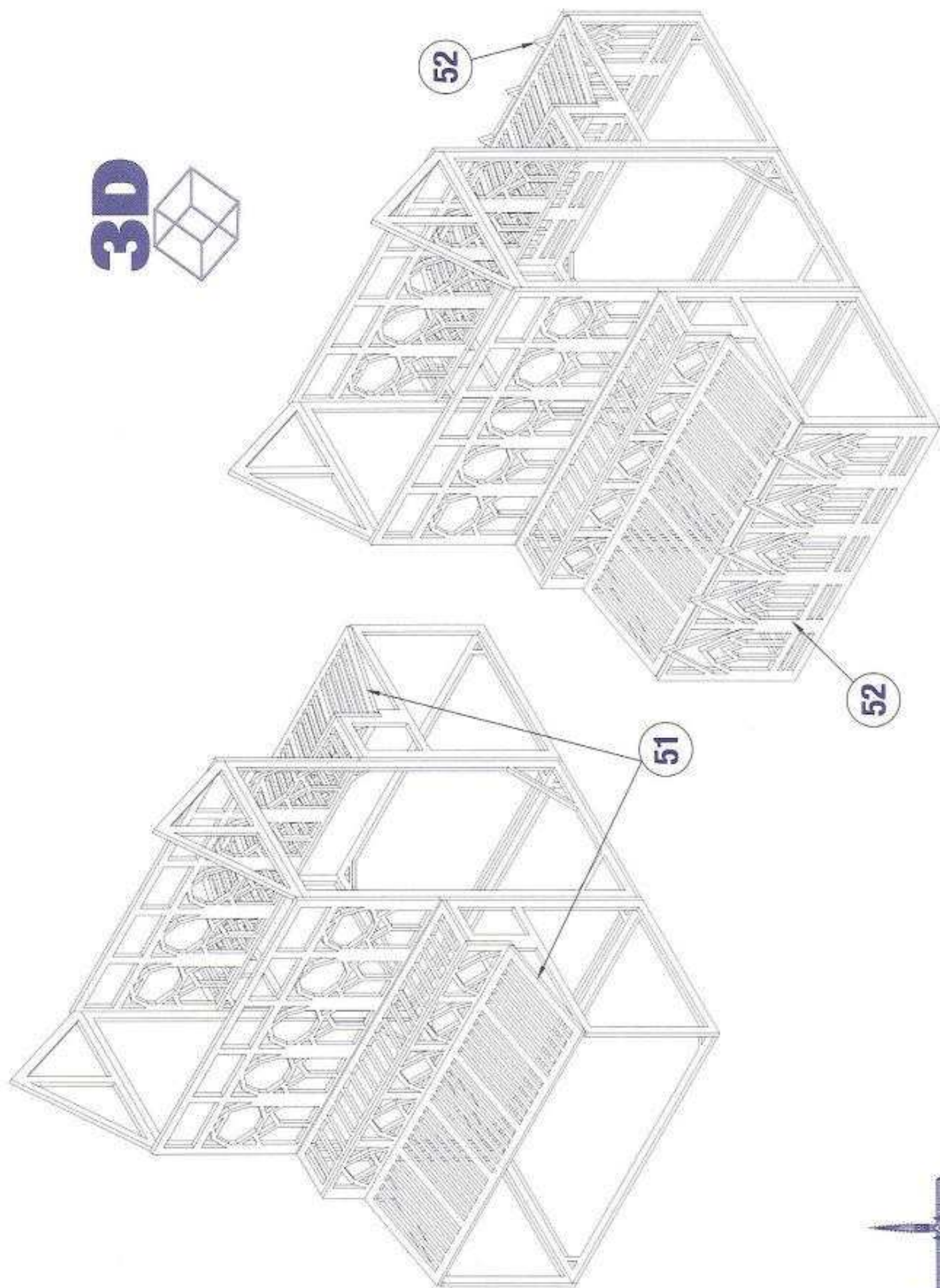

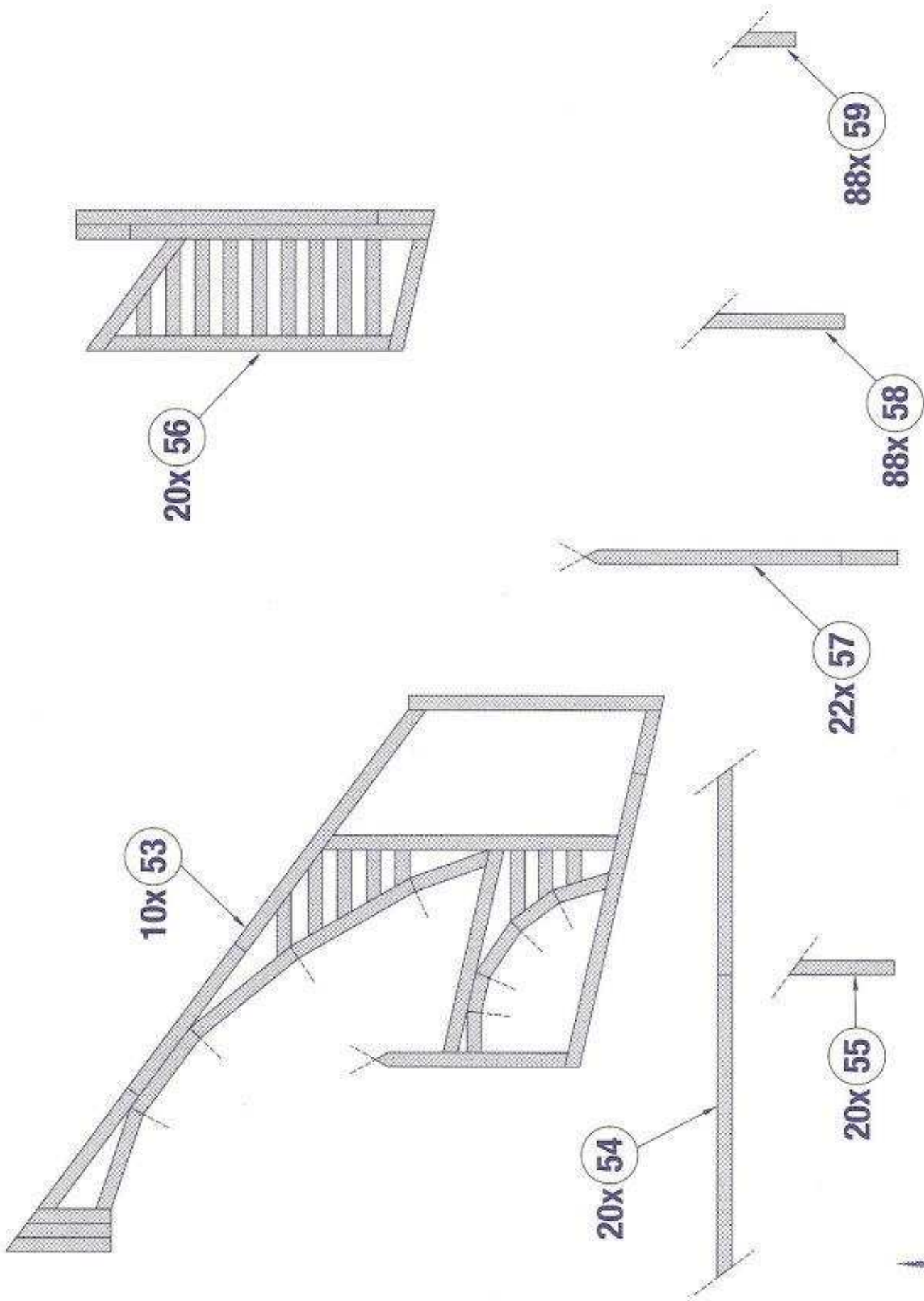

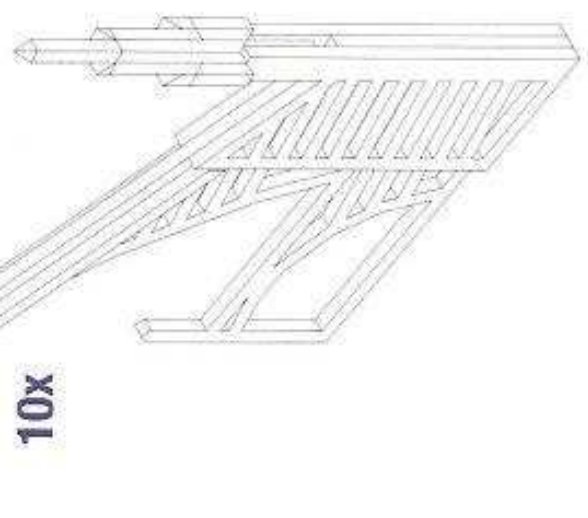

10x

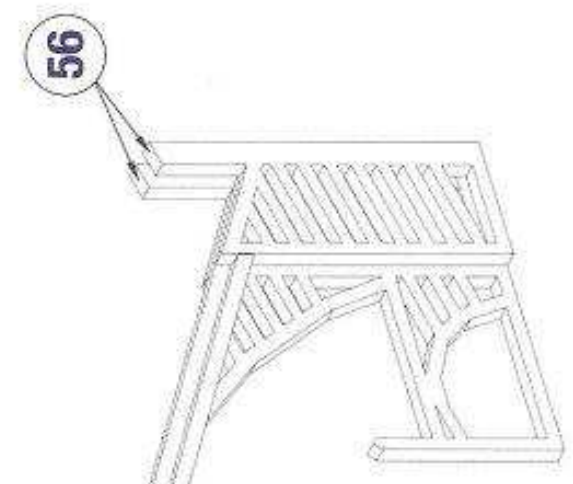
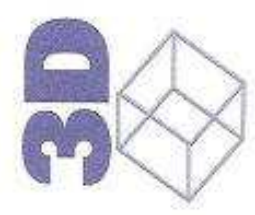

56

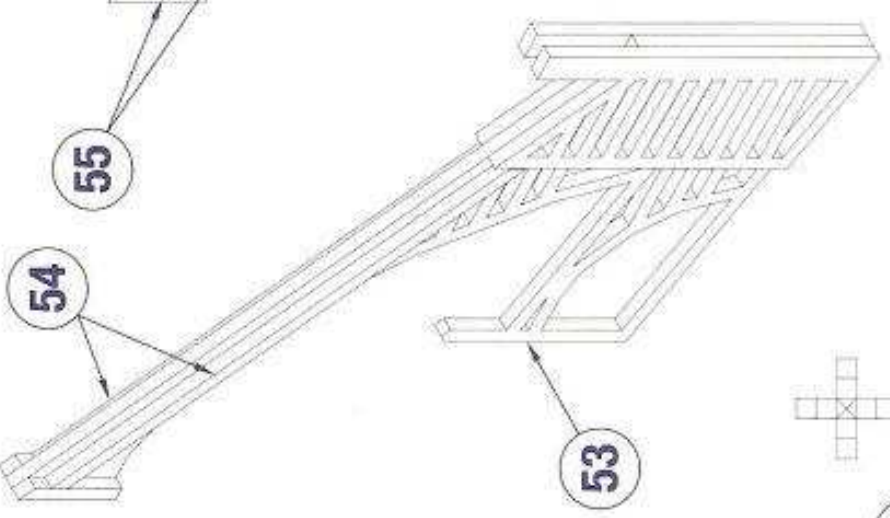

55

54

53



22x



57

58

59

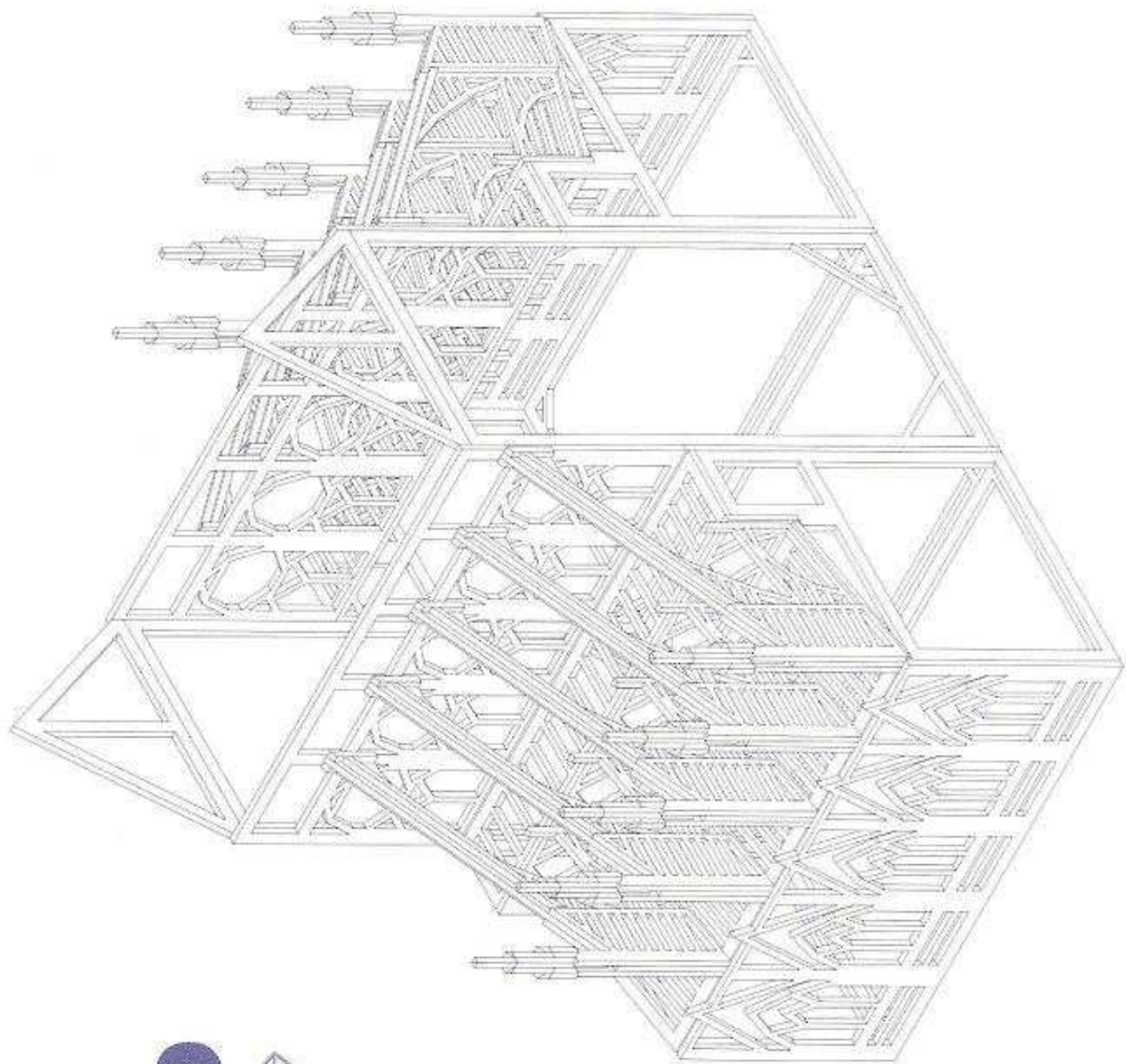
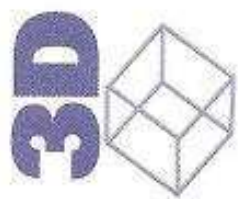

© 2006 Bojoux Inc.

[www.matchitecture.com](http://www.matchitecture.com)

MATCHITECTURE

**3D**

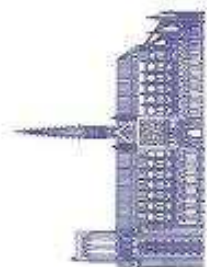
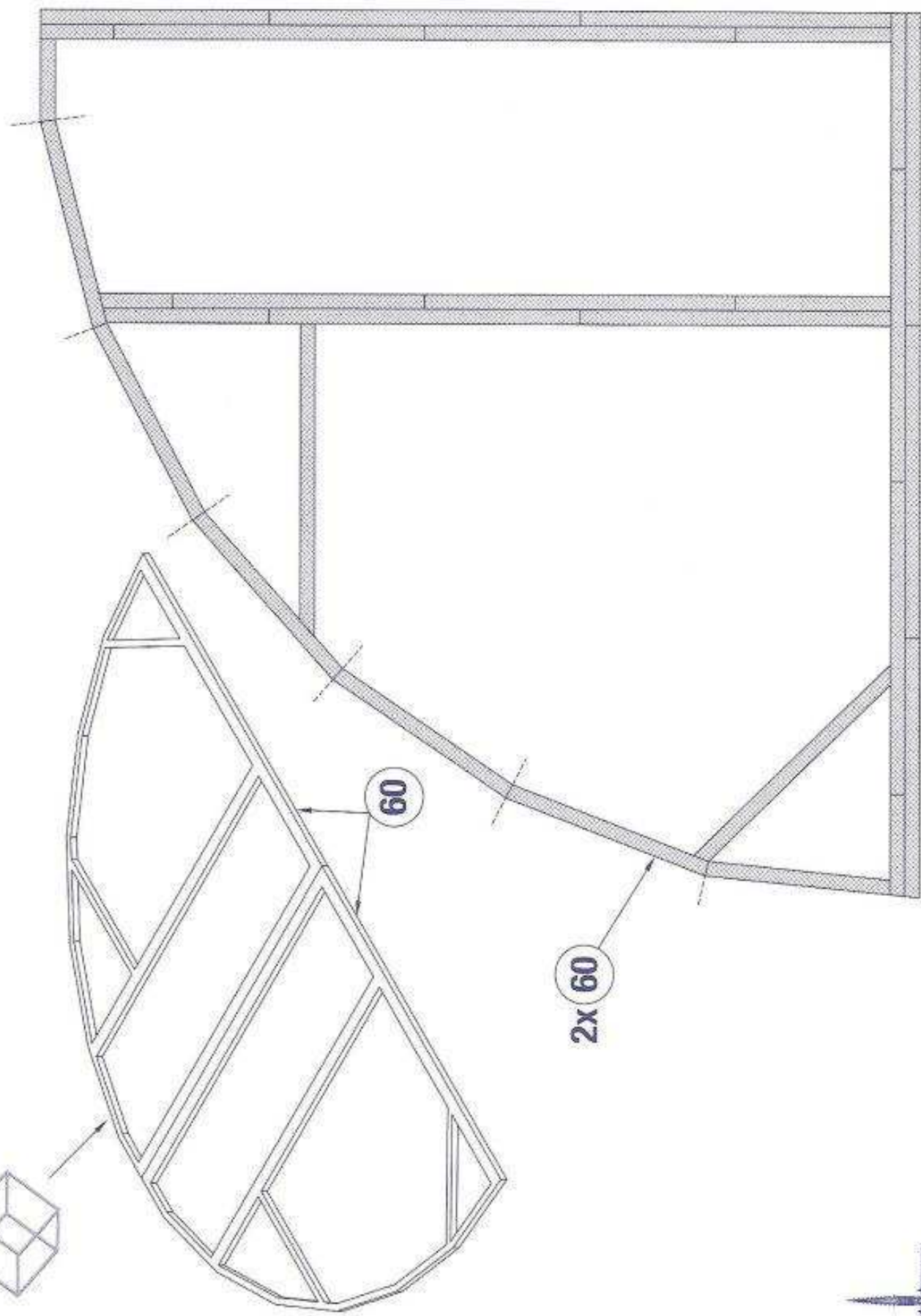

© 2006 Bojeux Inc.

[www.matchitecture.com](http://www.matchitecture.com)

**MATCHITECTURE**

**3D**

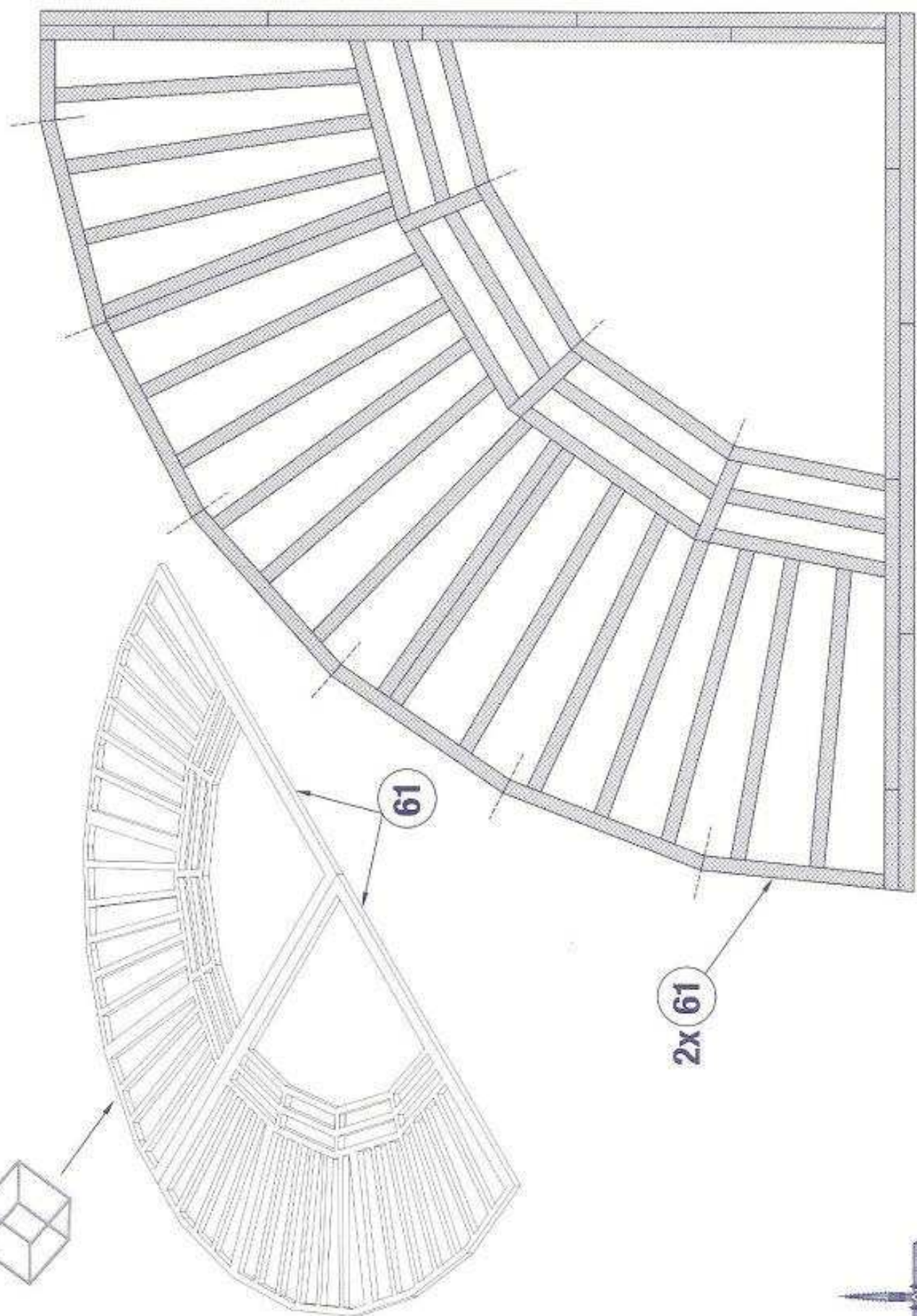

61

2x 61

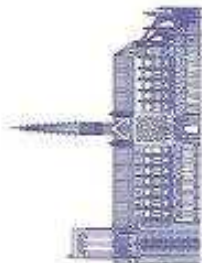

© 2005 Regieux Inc.

[www.matchitecture.com](http://www.matchitecture.com)

**MATCHITECTURE**

49 / 105

**3D**

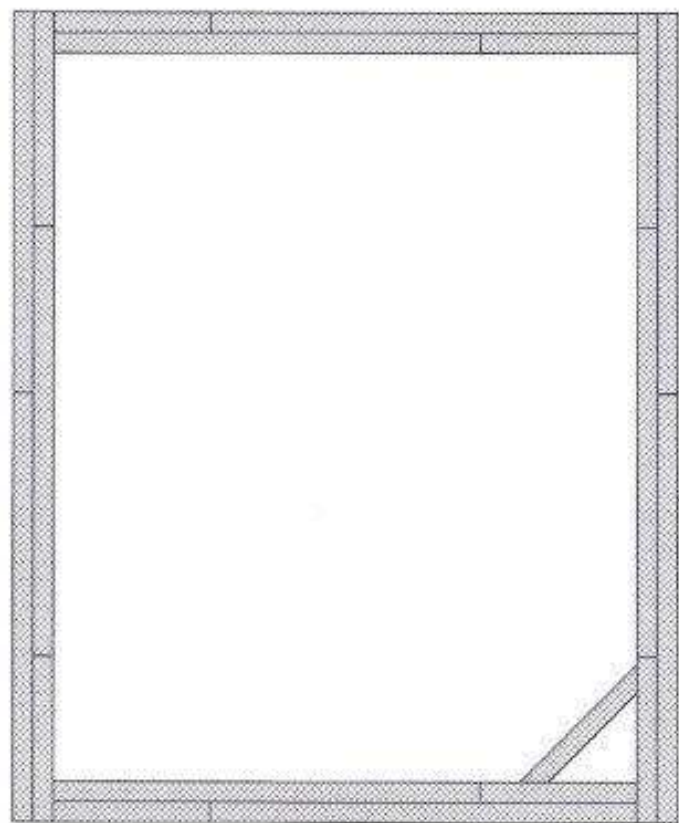

**3x 62**

**62**

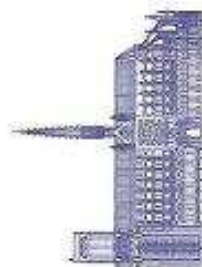
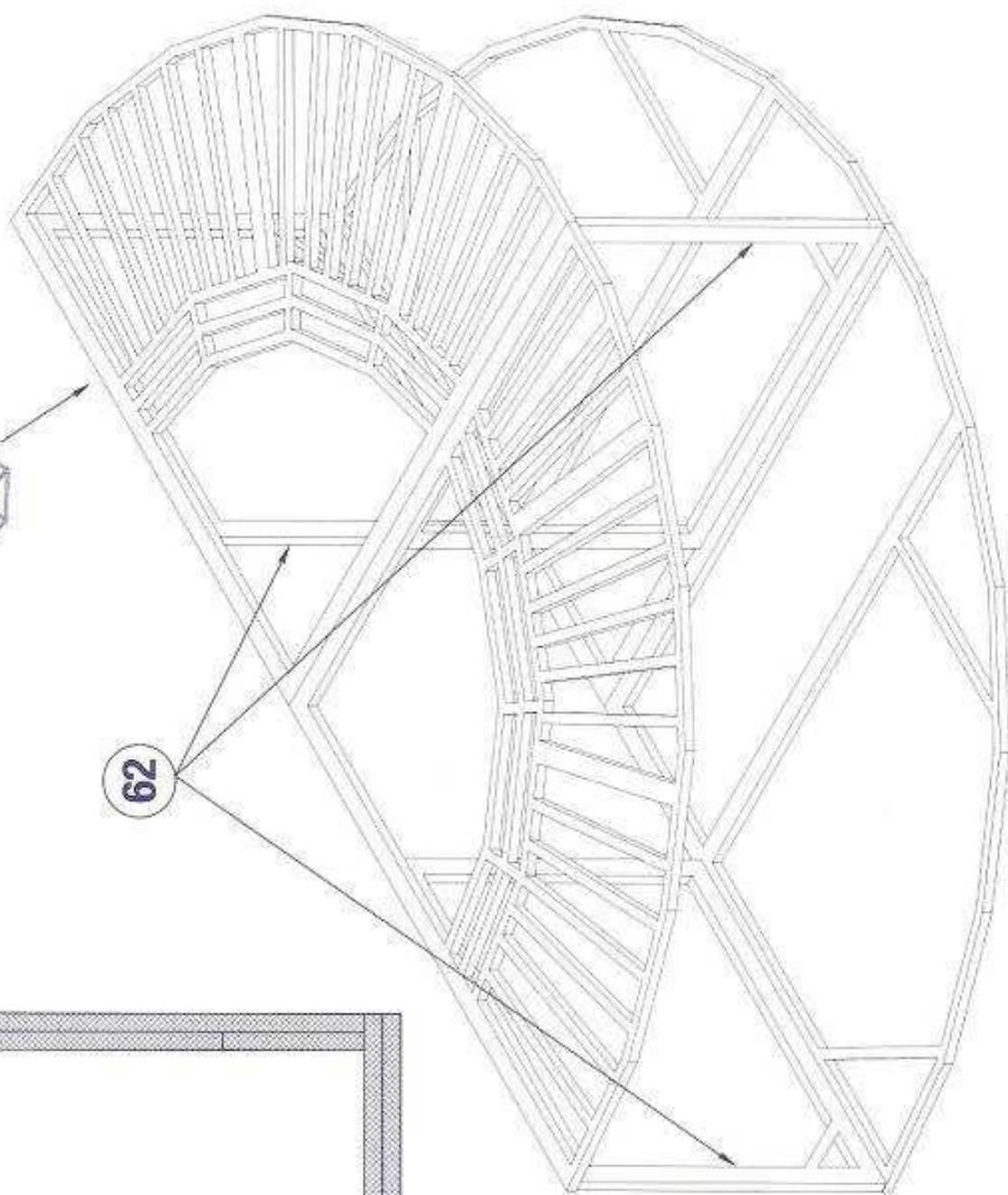

© 2008 Begoux Inc.

[www.matchitecture.com](http://www.matchitecture.com)

**MATCHITECTURE**

50 / 105

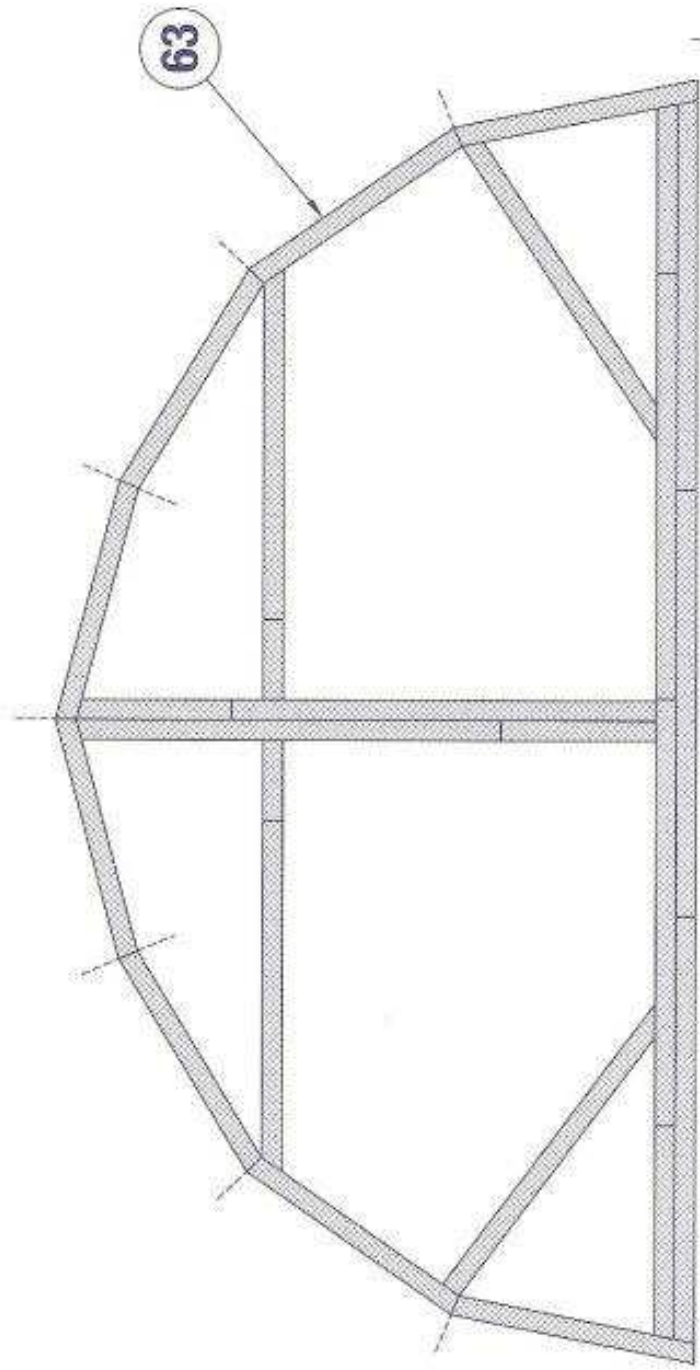

65

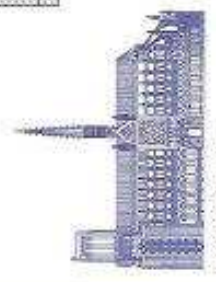
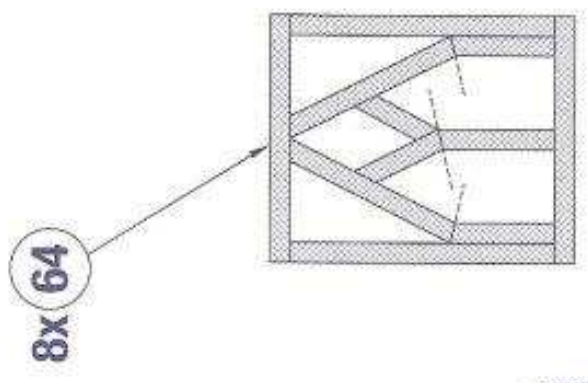
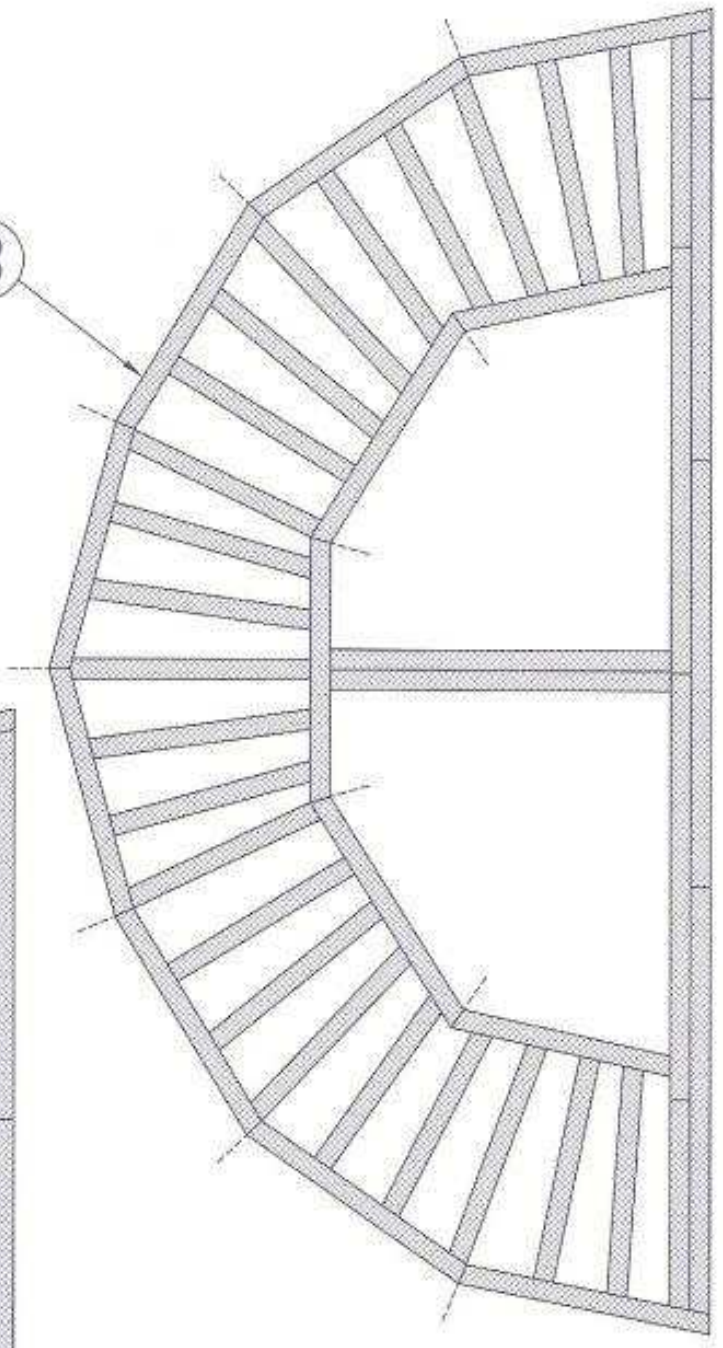

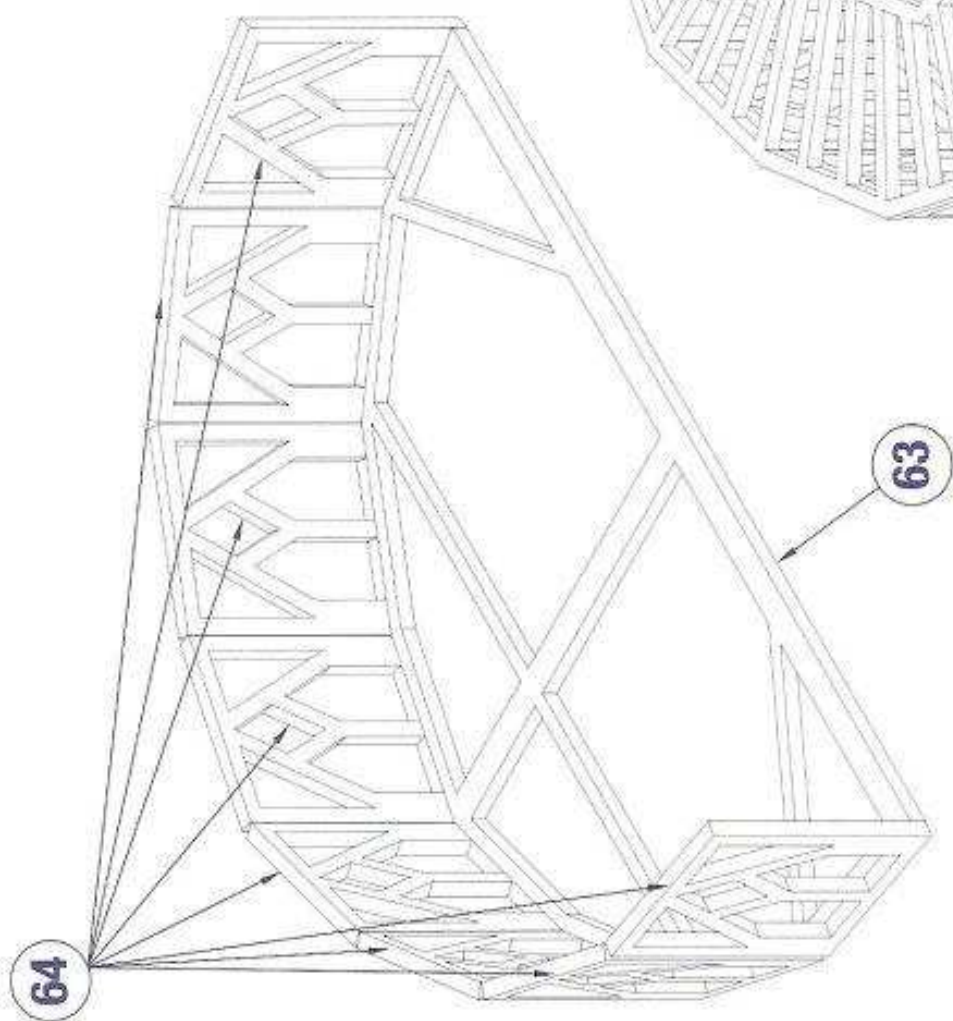

65

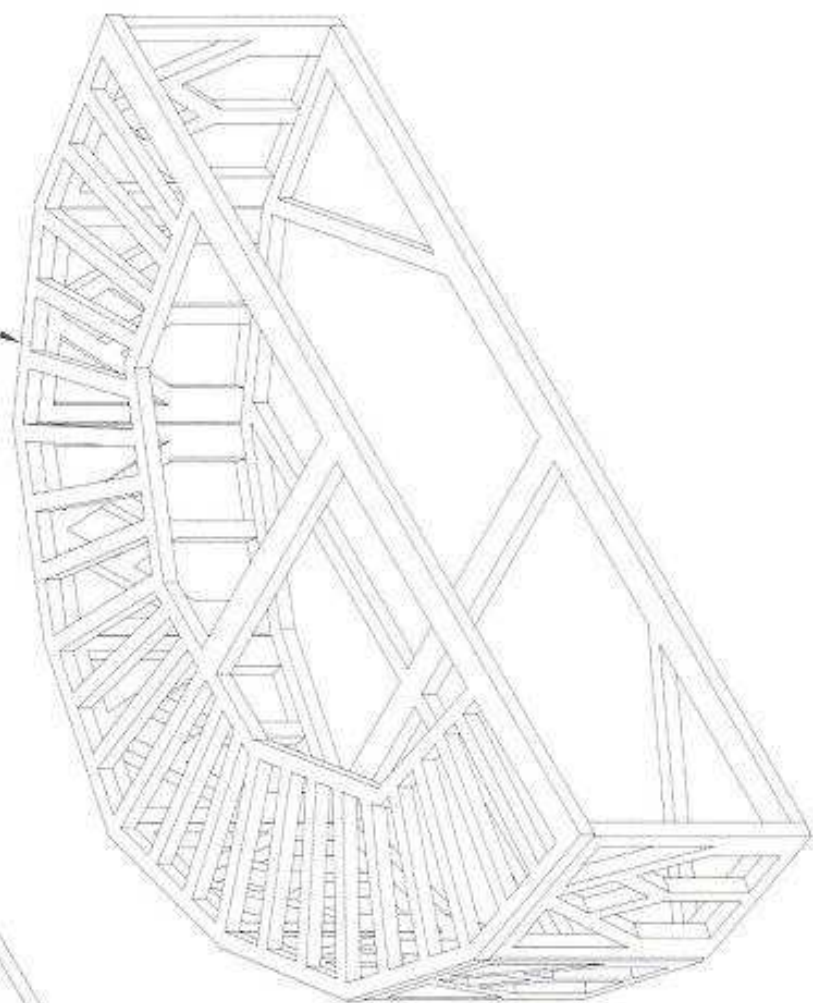

63

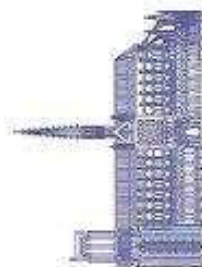

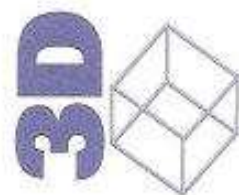
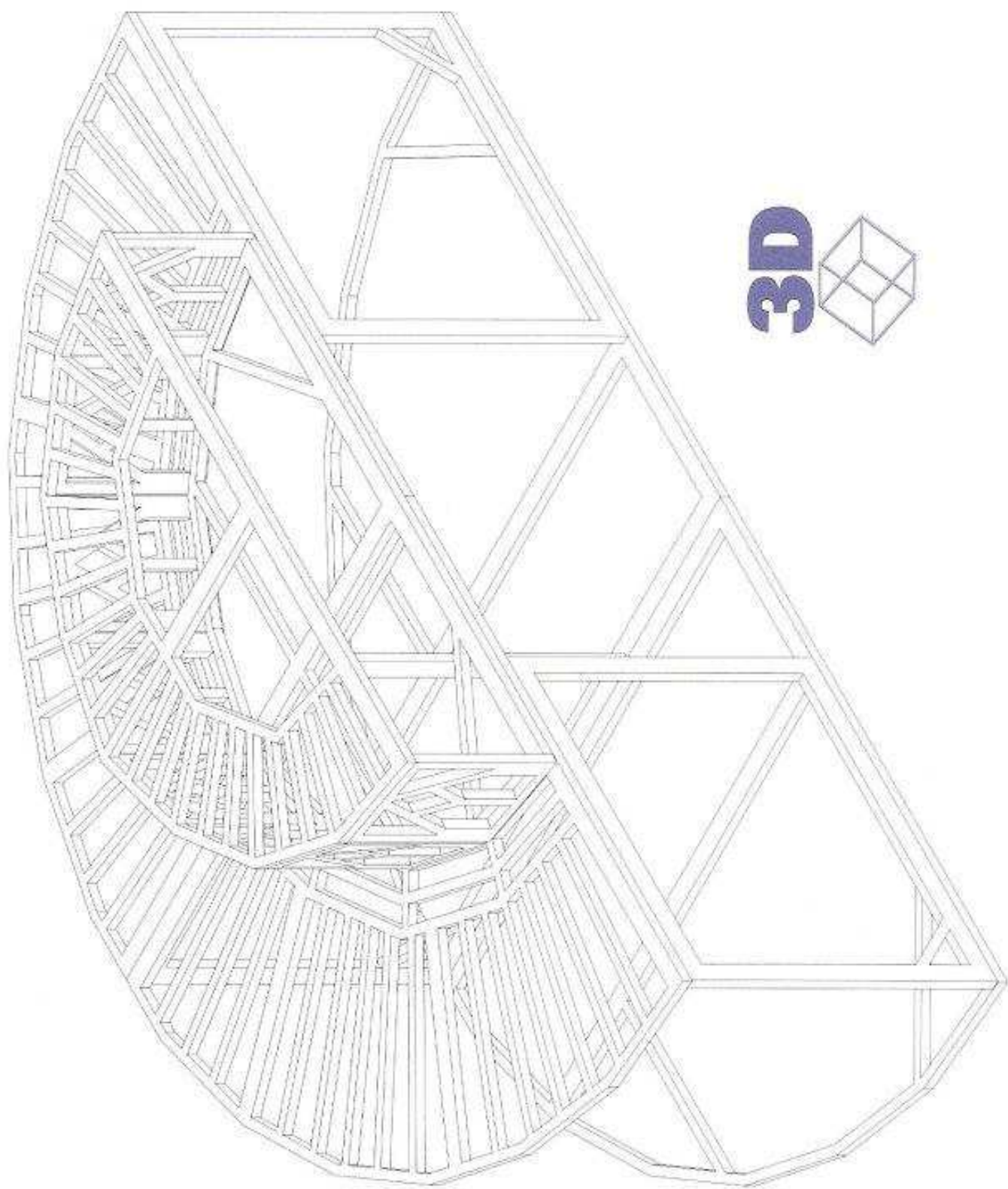

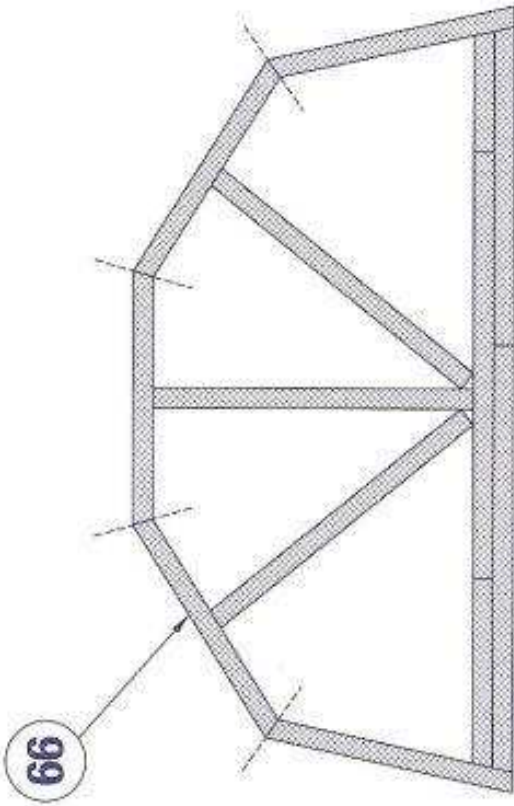

66

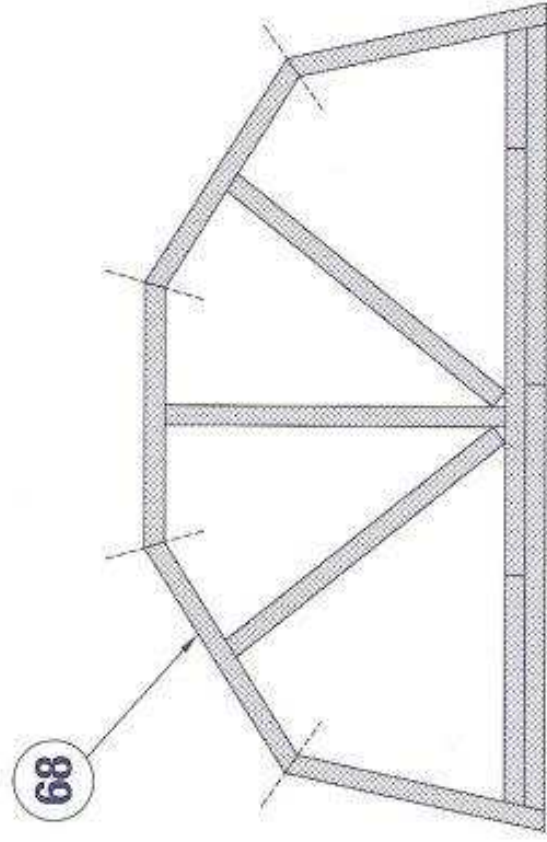

68

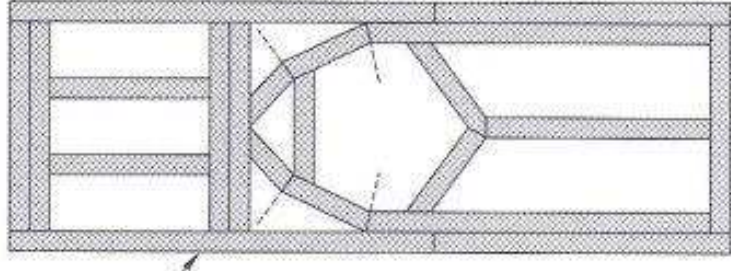

5x67

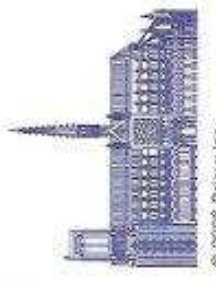

© 2006 Bojeux, Inc.

www.matchitecture.com

MATCHITECTURE

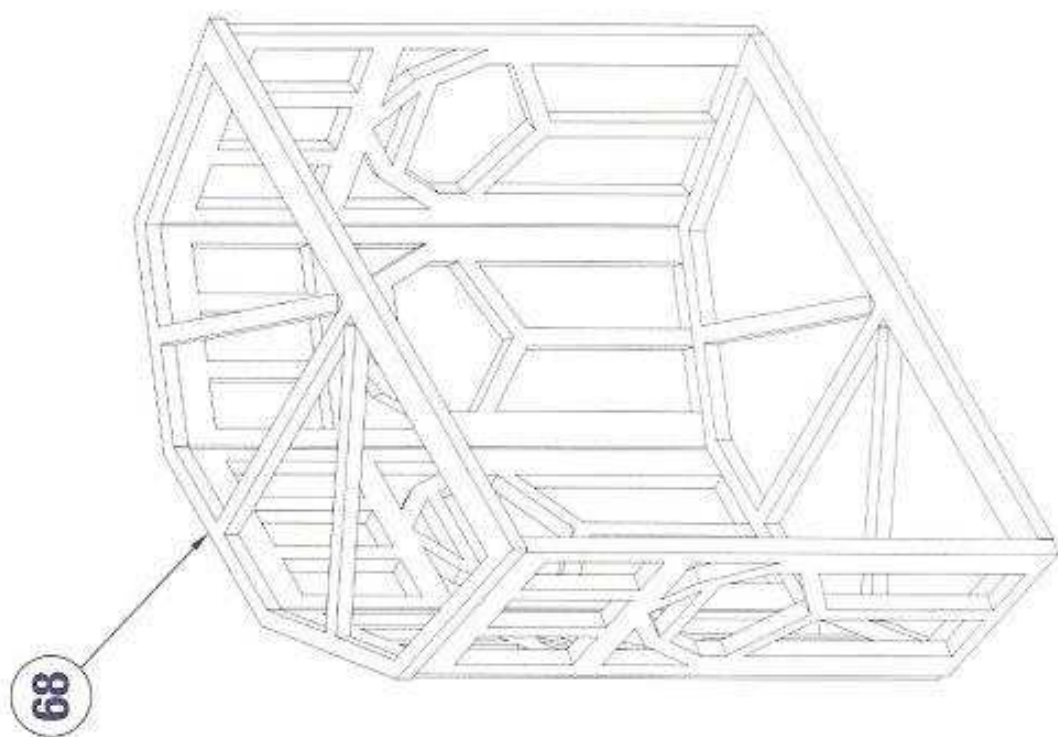
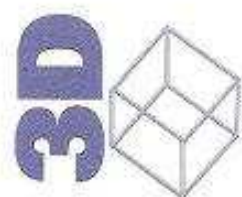
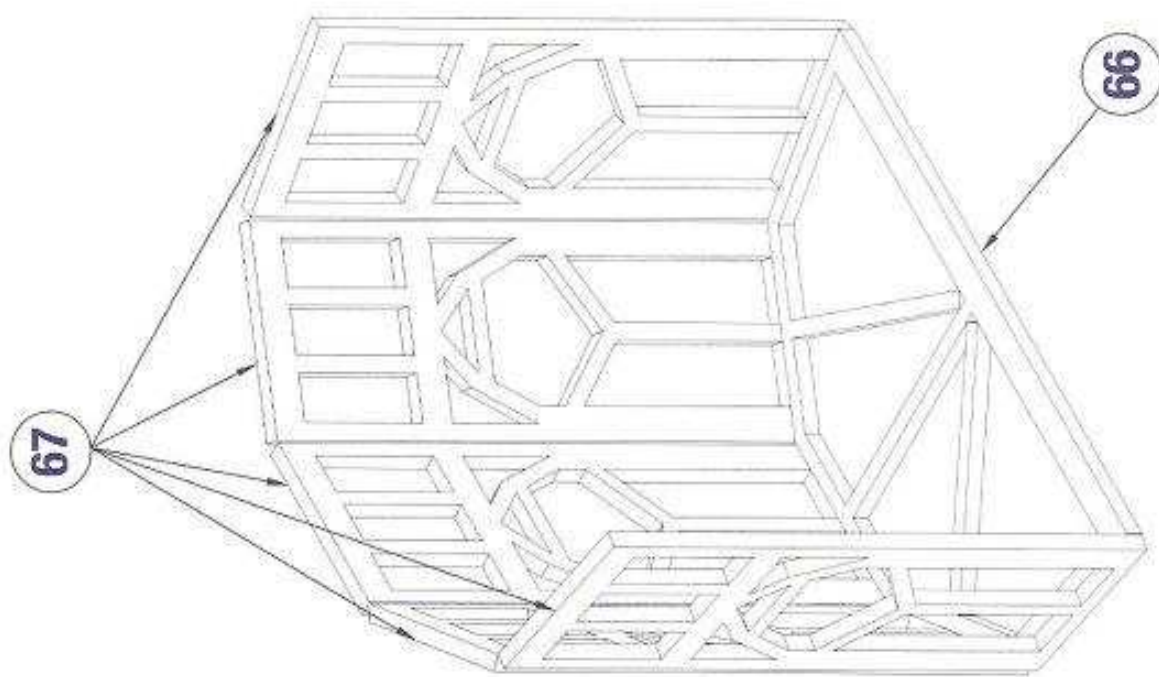

**3D** 

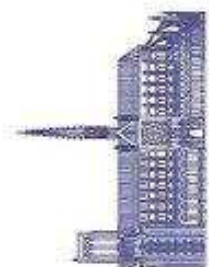
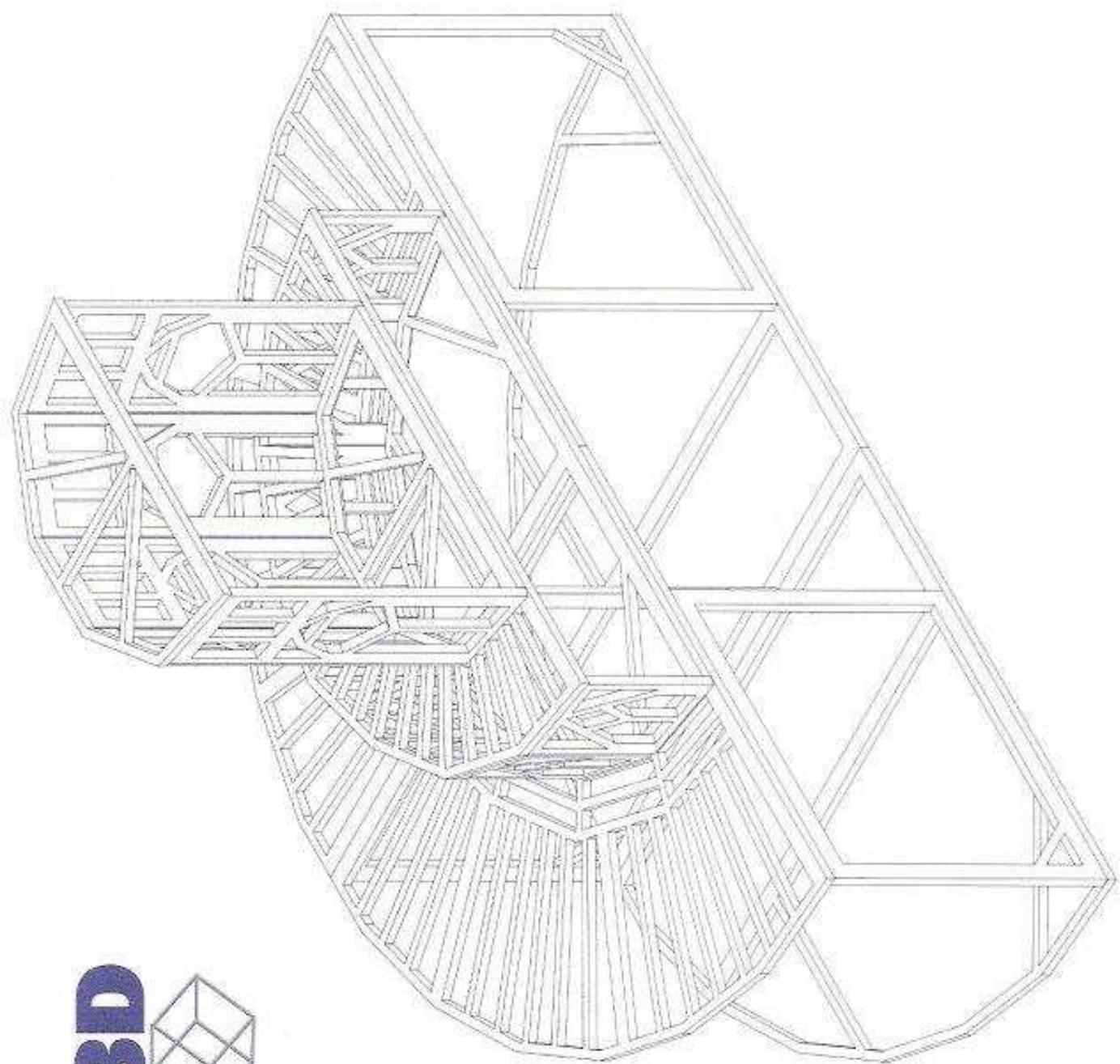

© 2006 Bujoux Inc.

[www.matchitecture.com](http://www.matchitecture.com)

**MATCHITECTURE**

56 / 105

**3D**

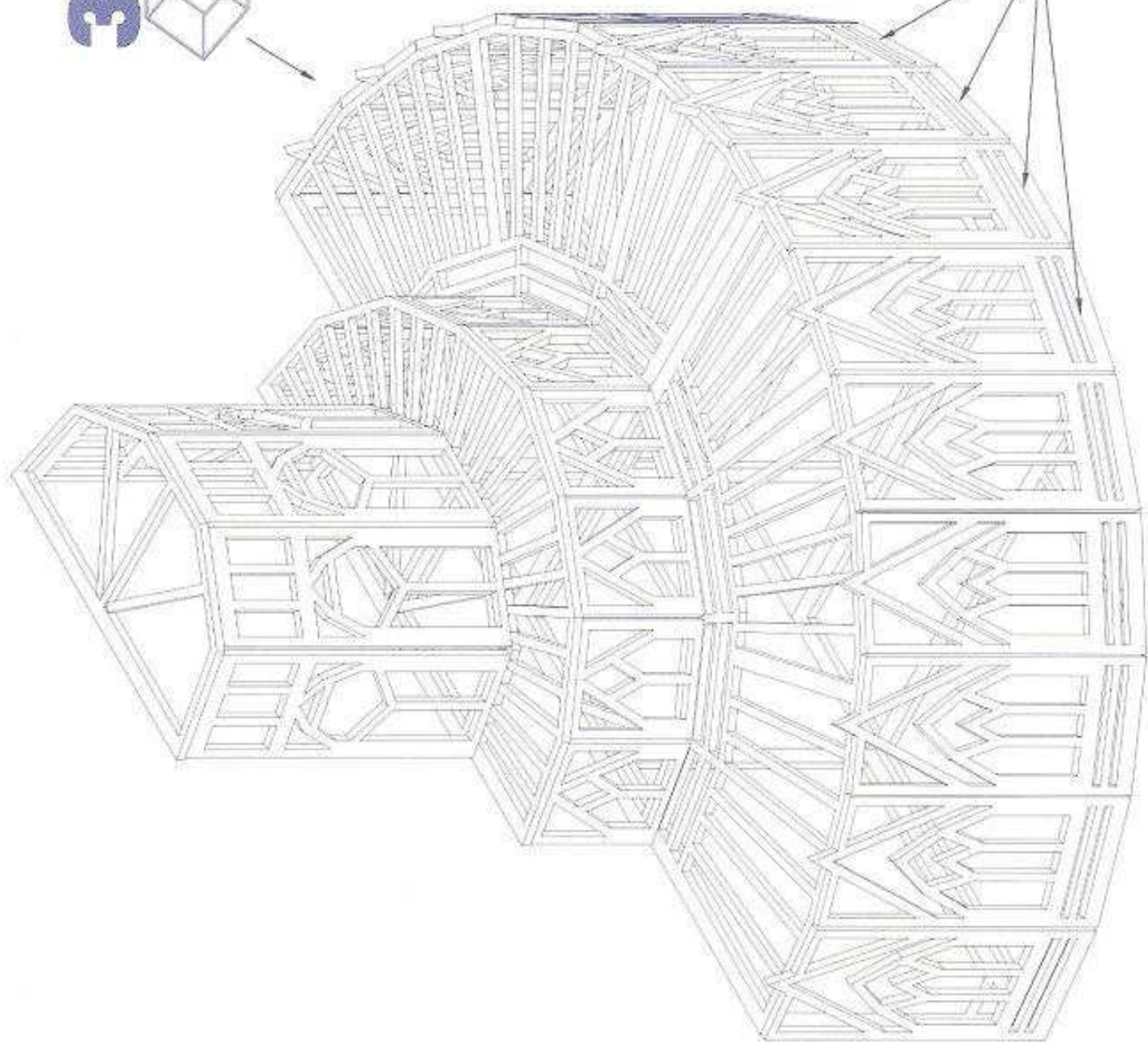

**13x 69**

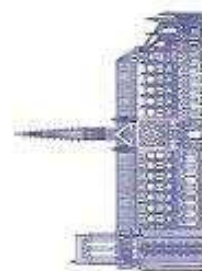
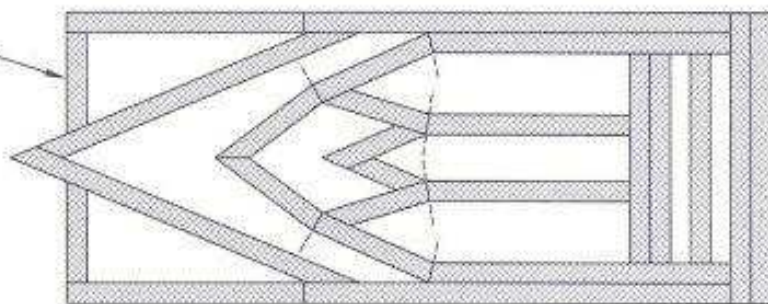

© 2006 Belex Inc.

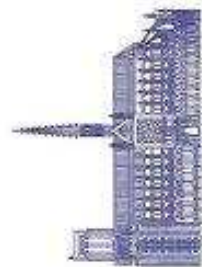
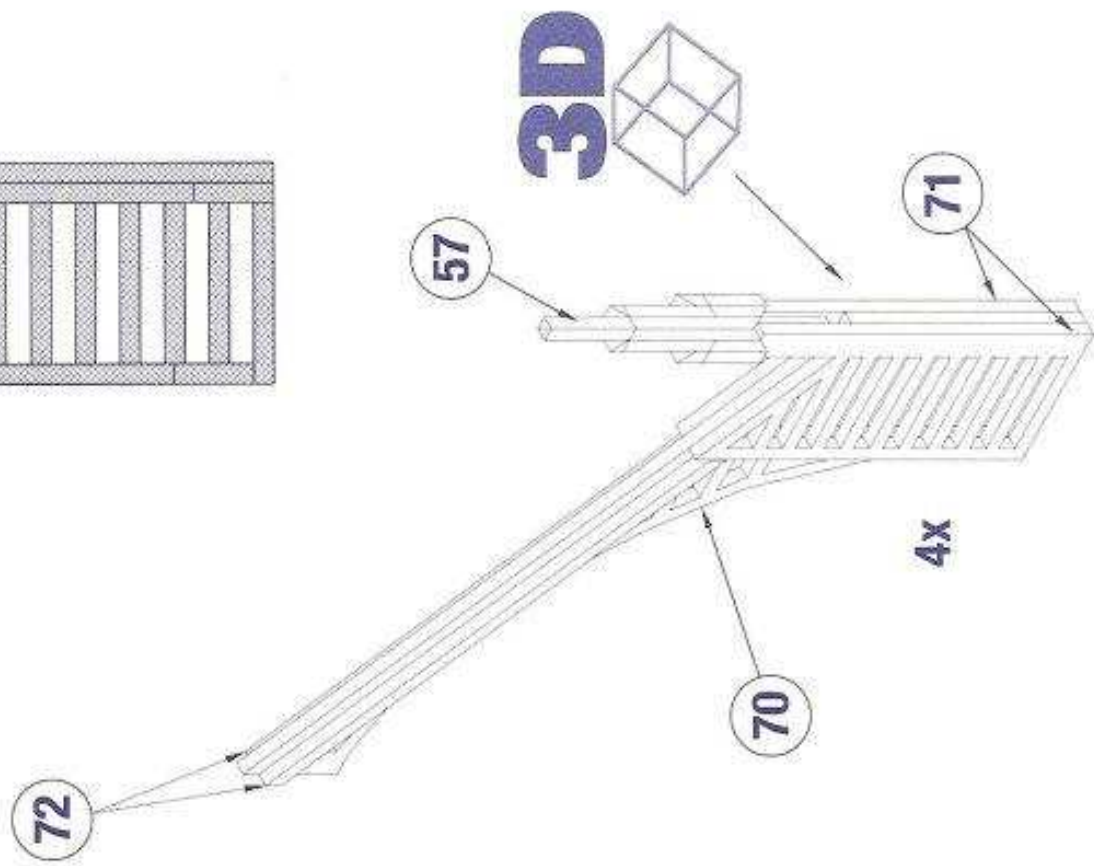
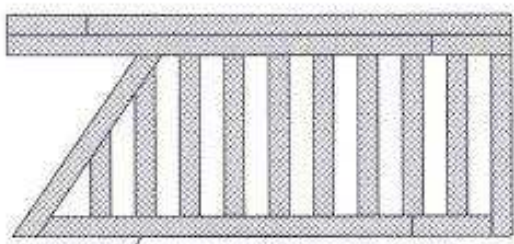
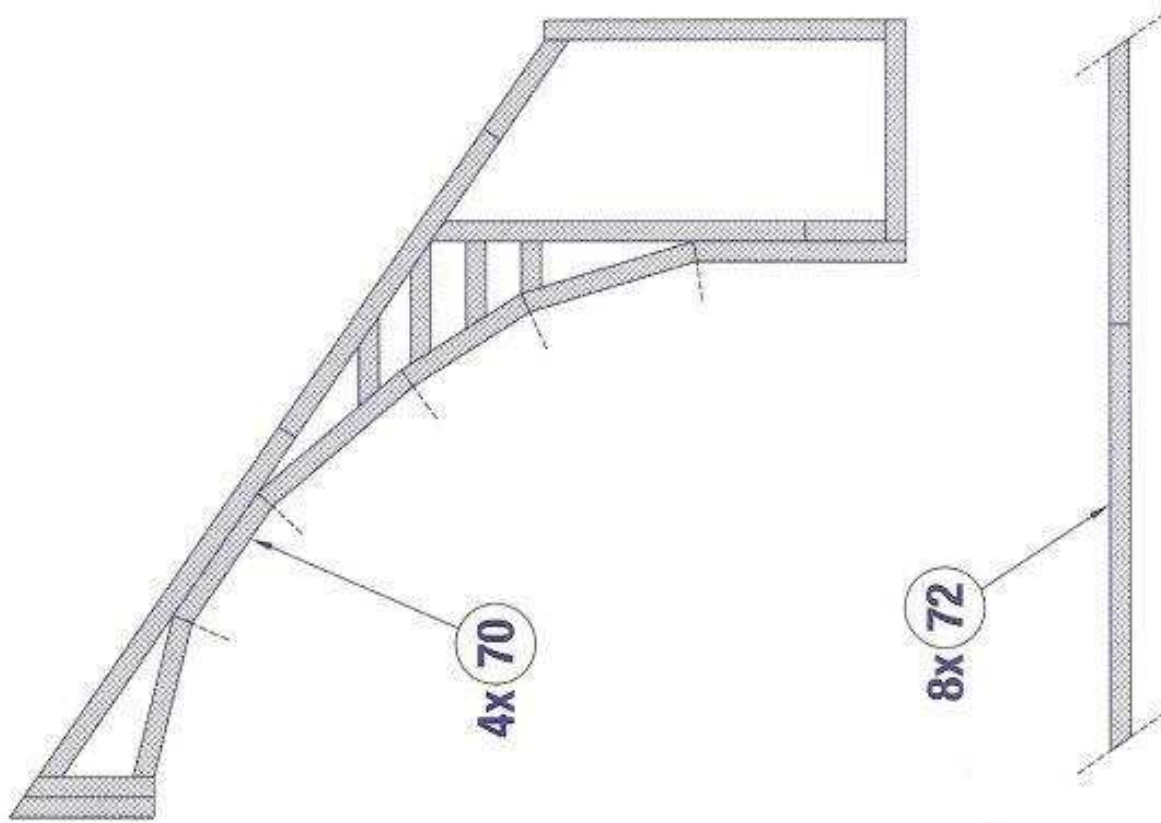

**3D**



16x 73



16x 74

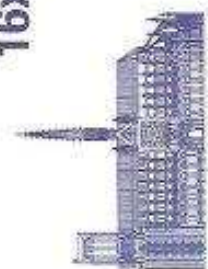
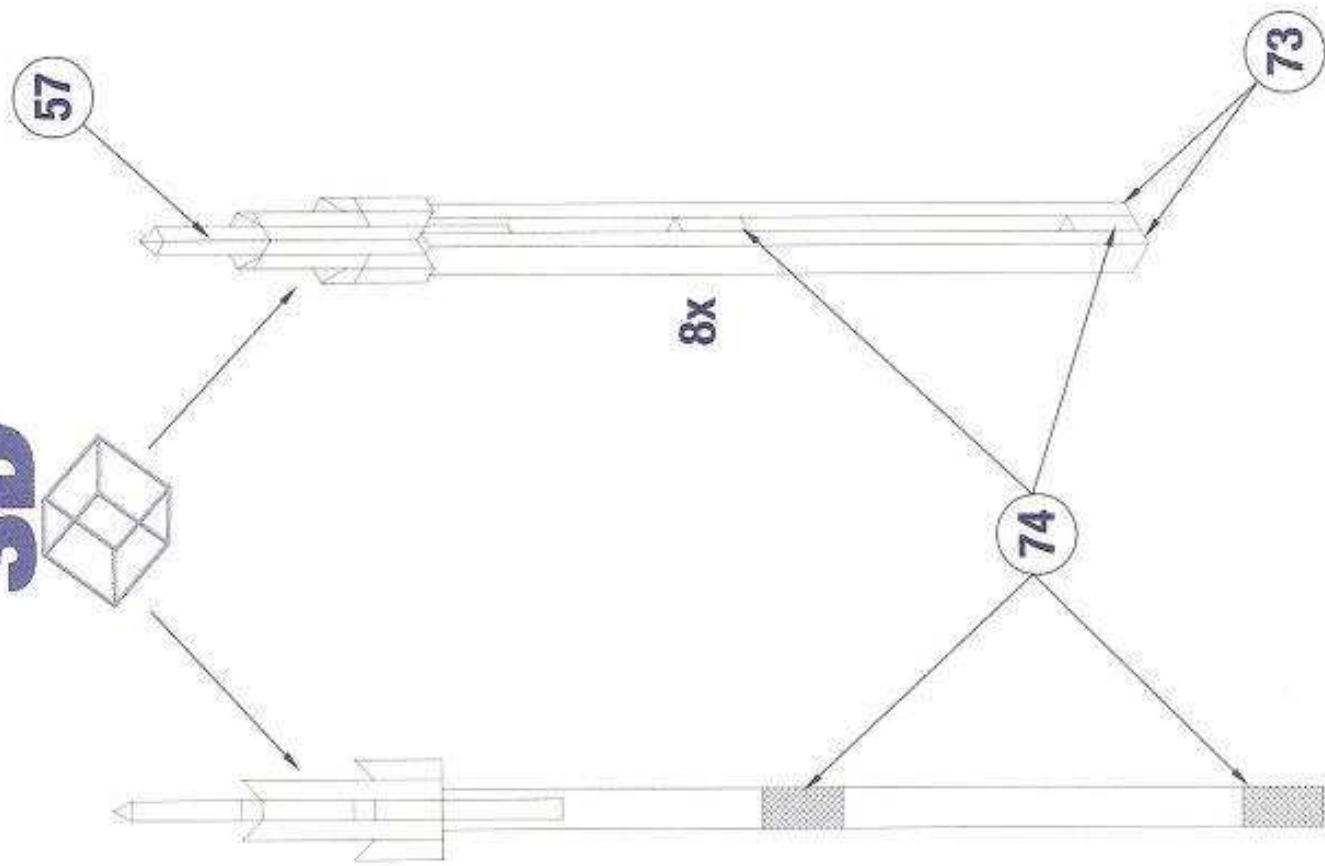

**3D** 

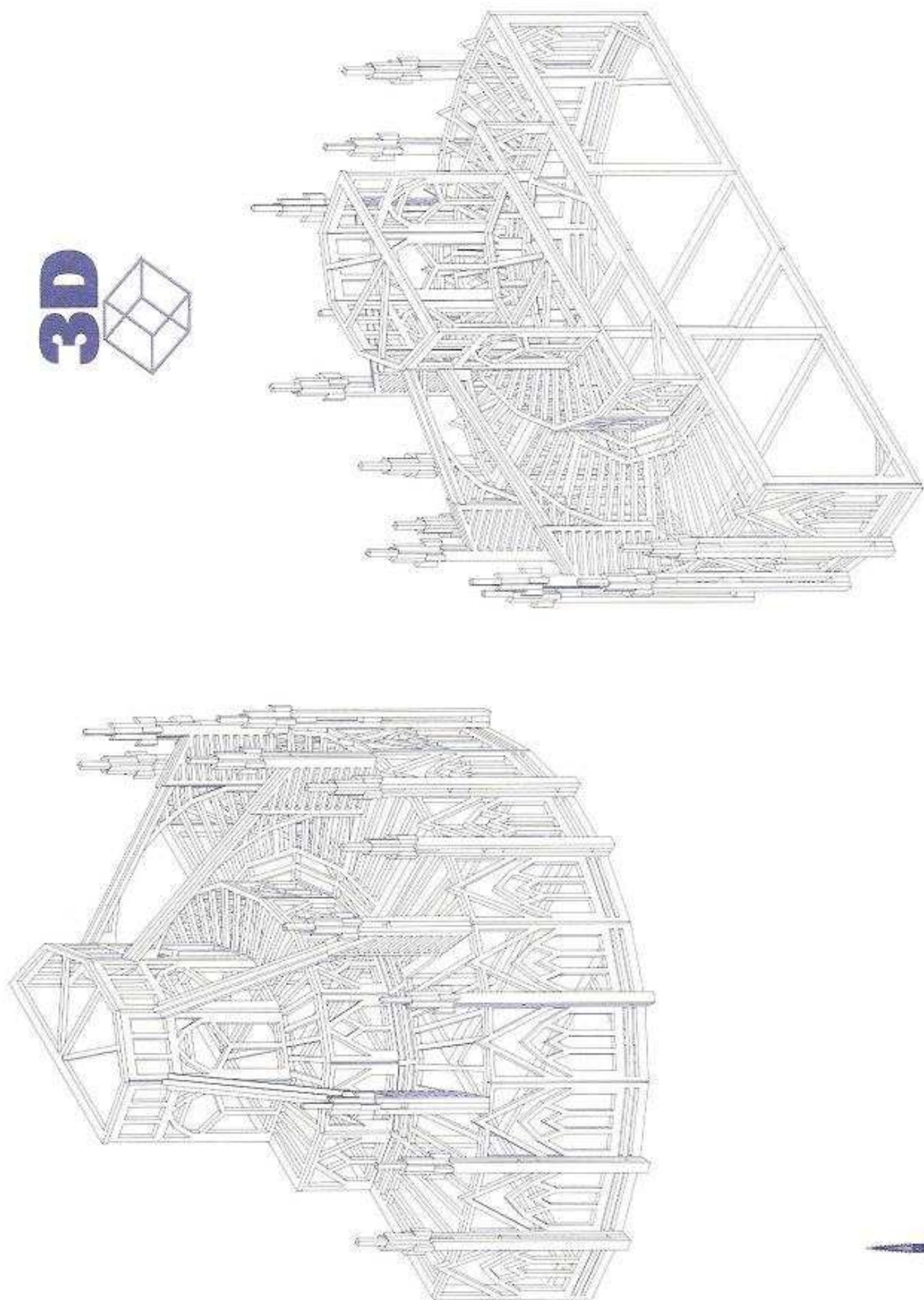

© 2006 Bajoux Inc.

[www.matchitecture.com](http://www.matchitecture.com)

**MATCHITECTURE**

60 / 105

**3D**

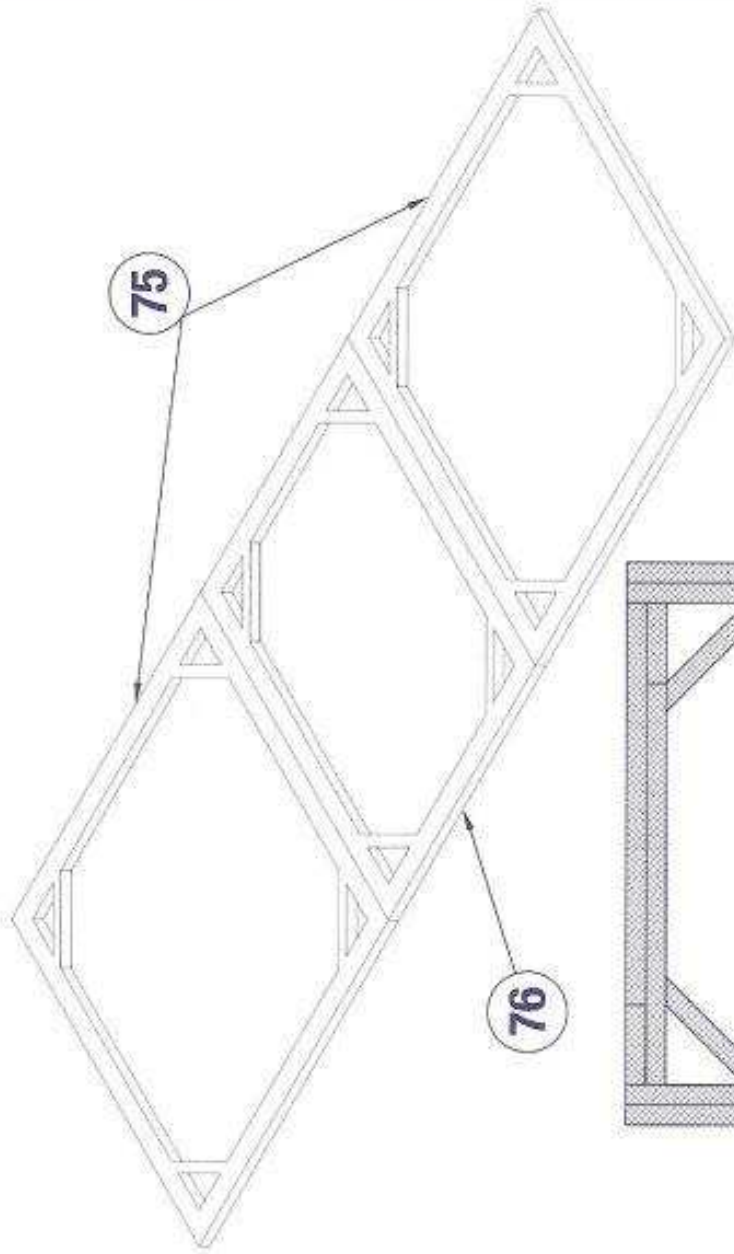

2x 75

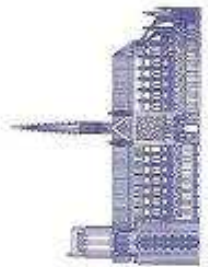
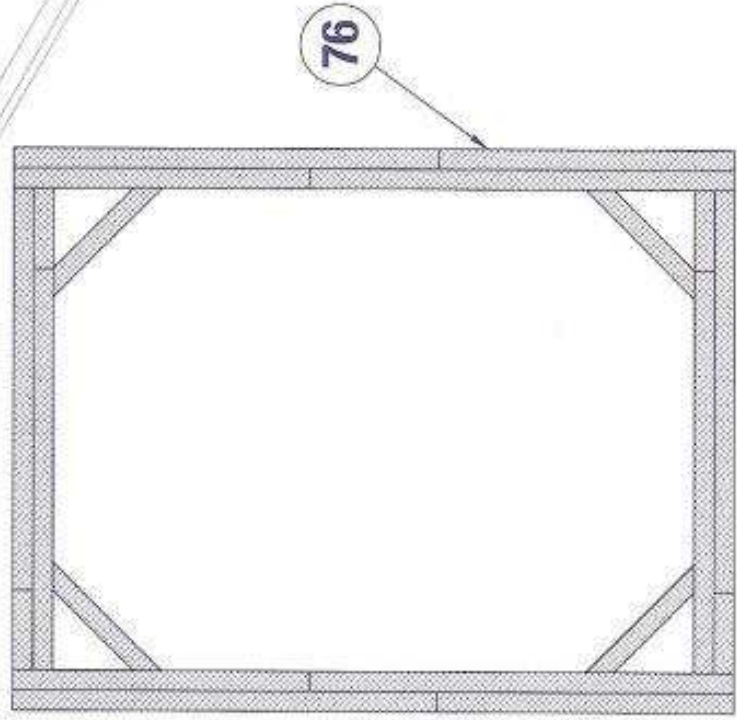
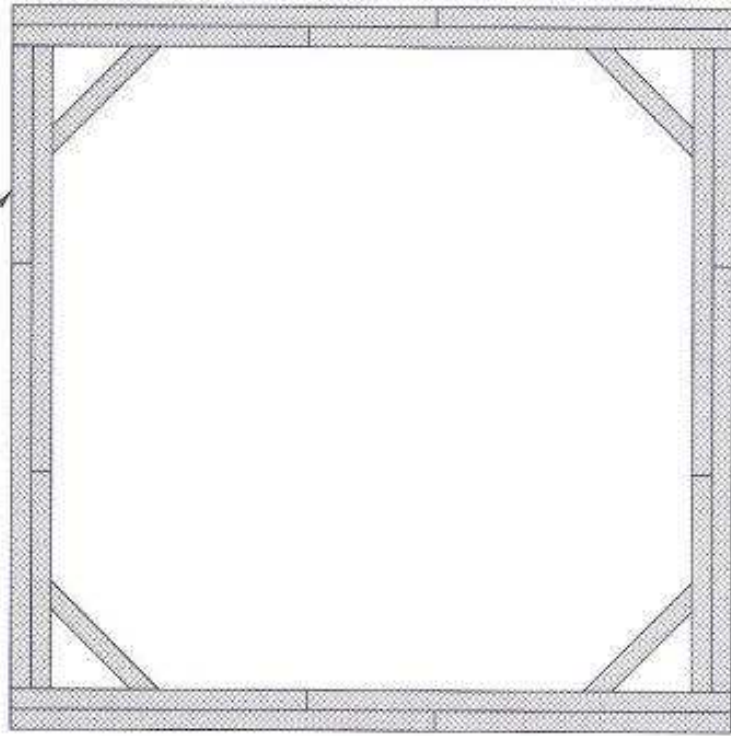

2x 77

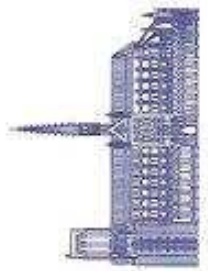
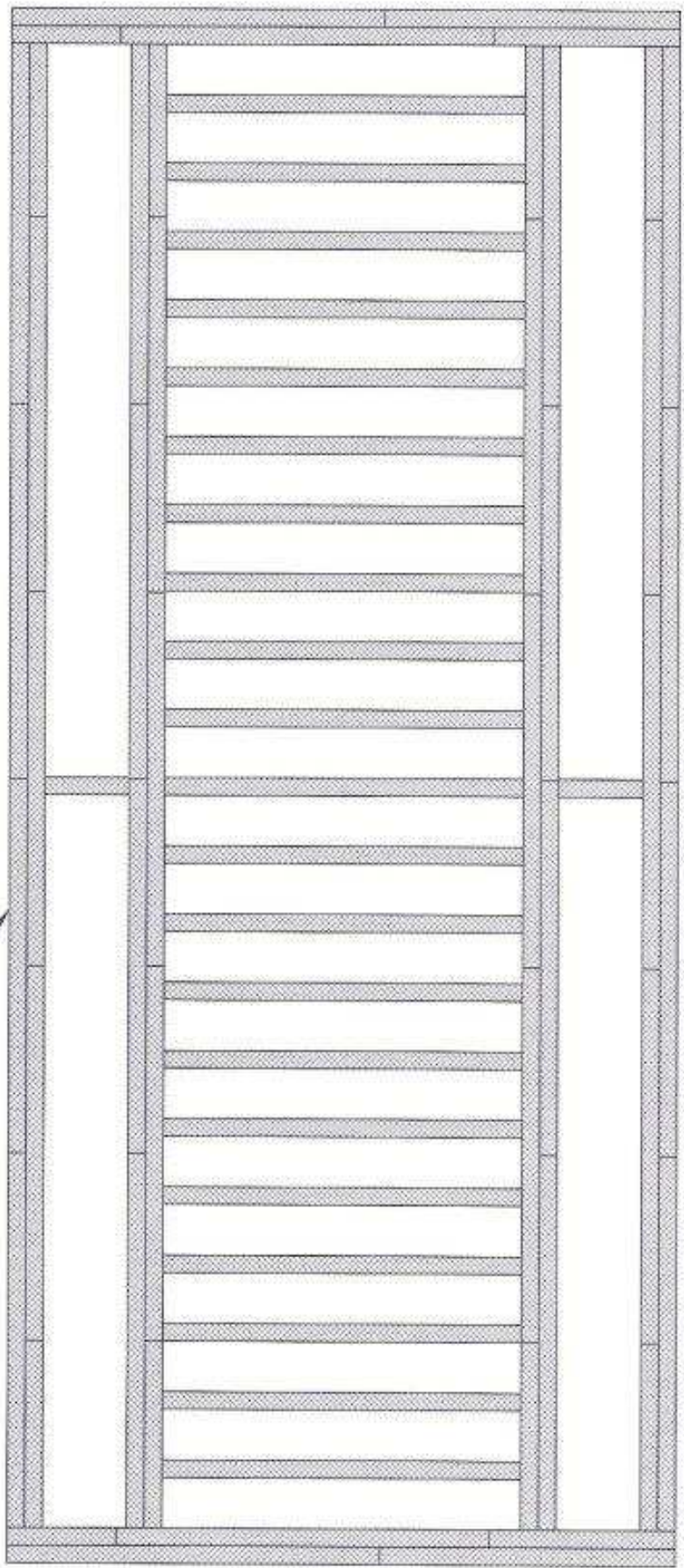

2x 78

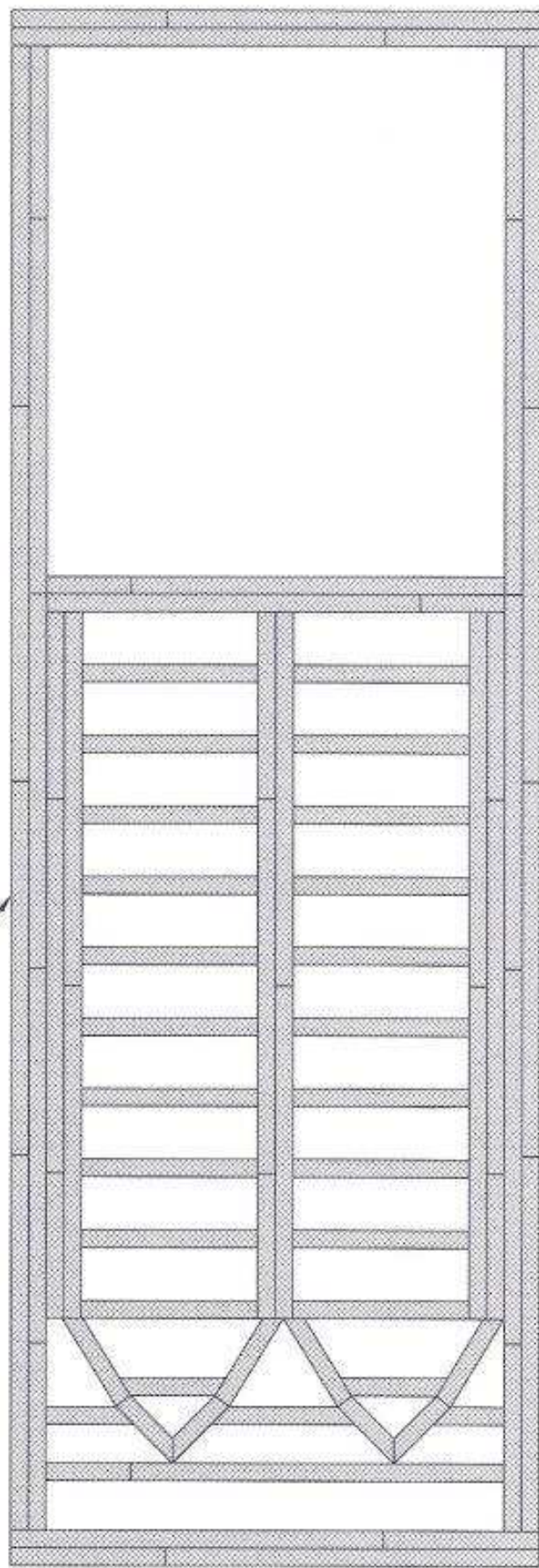

79

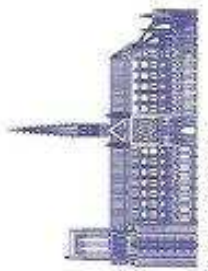
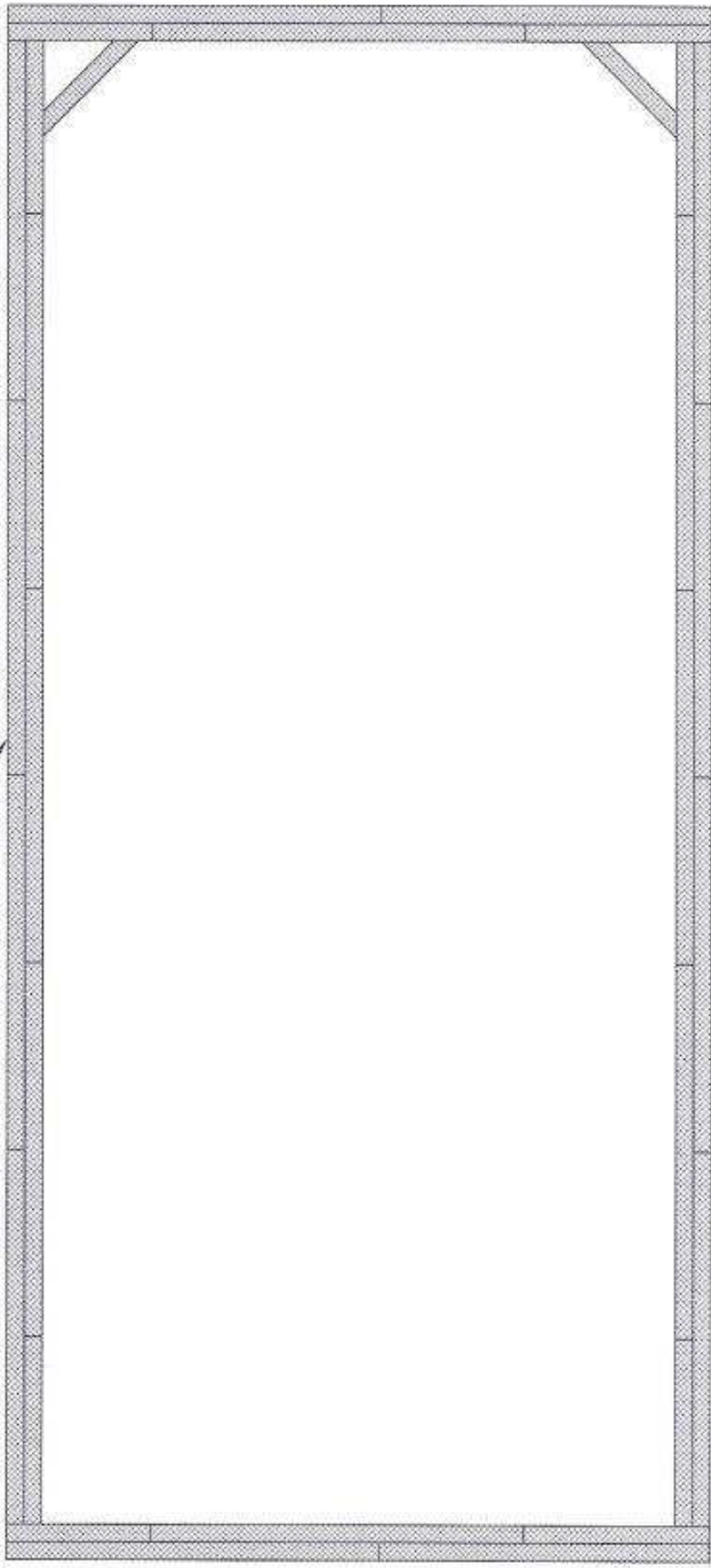

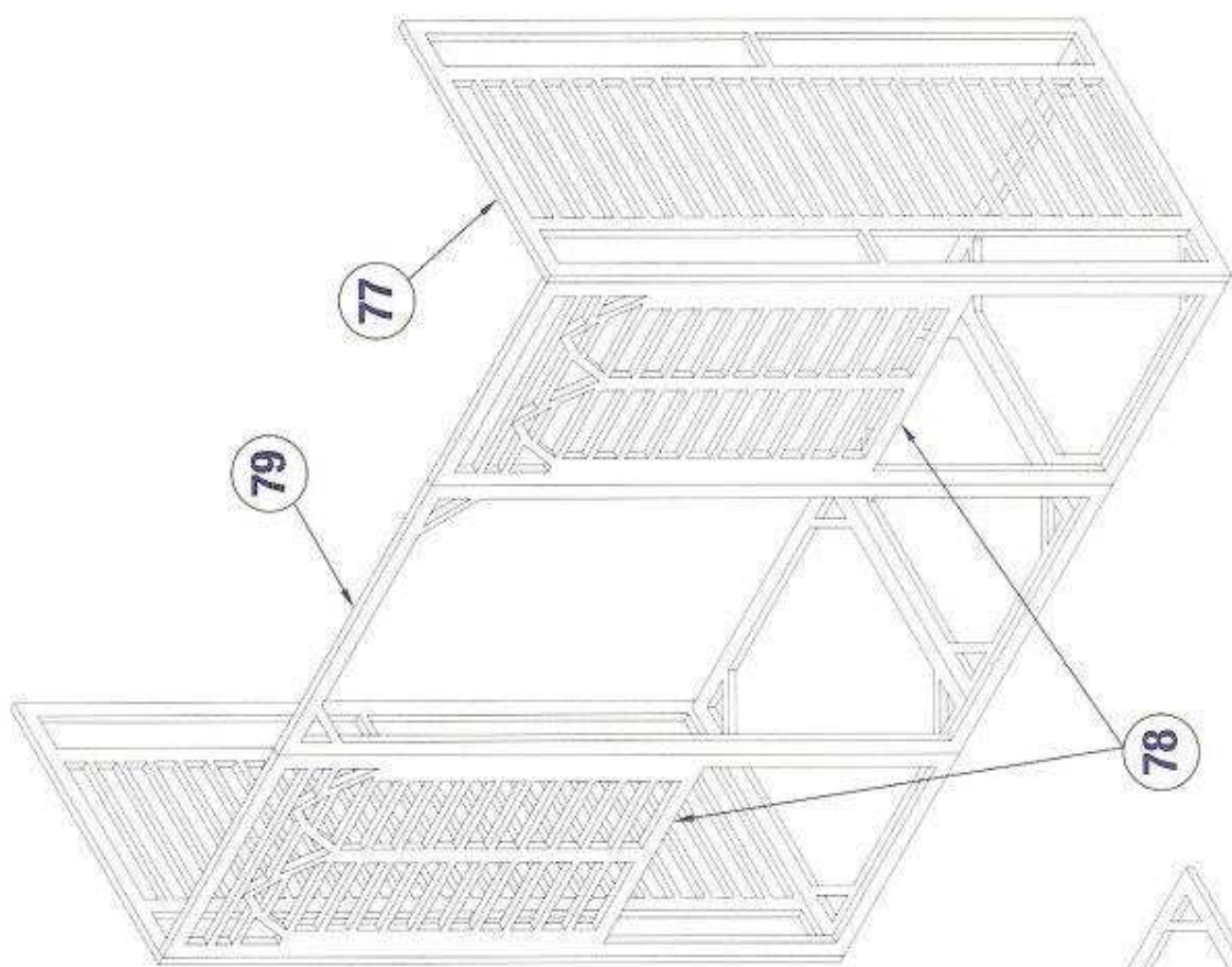

77

**3D**

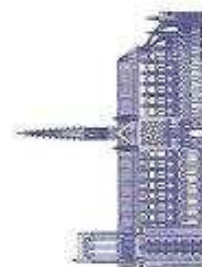
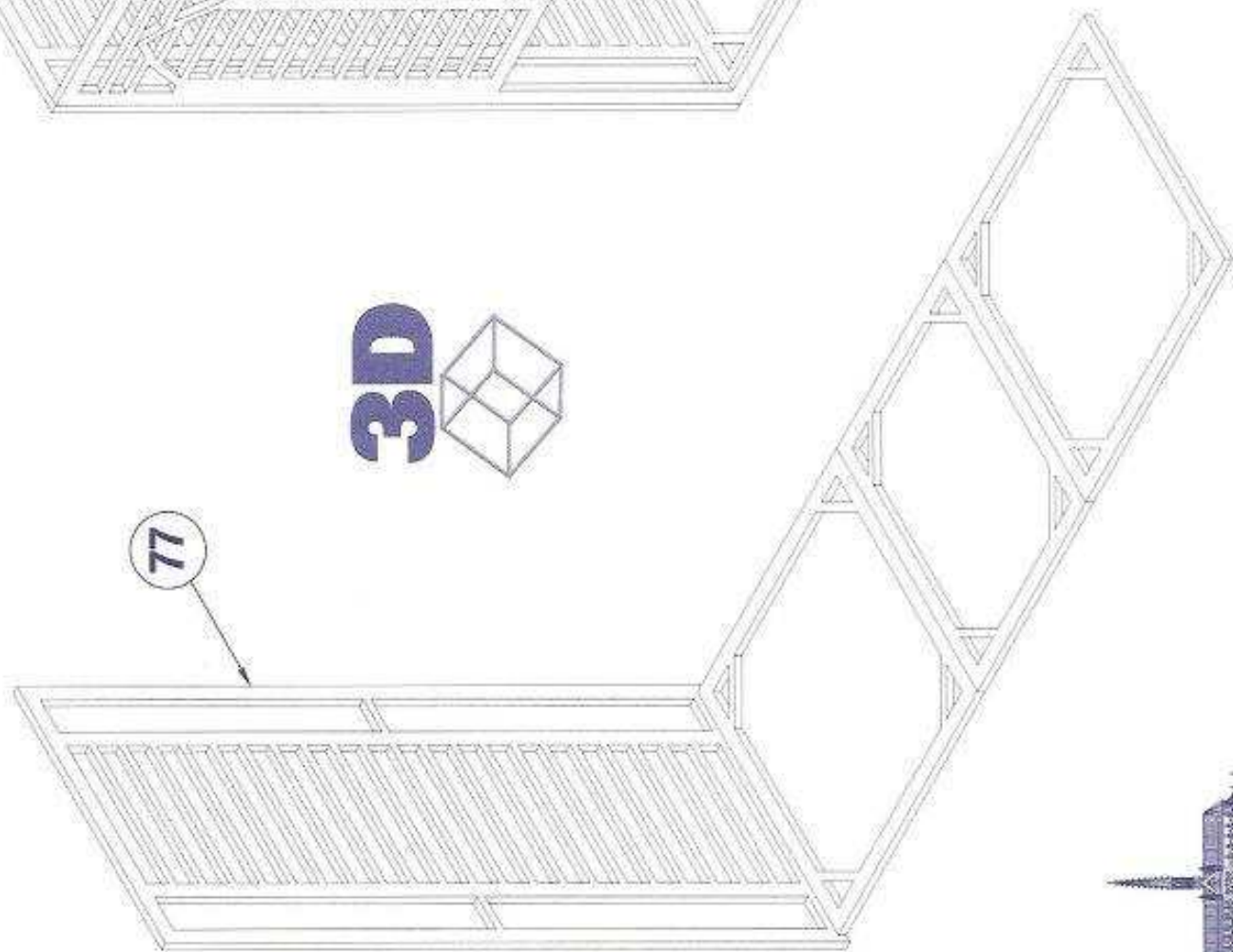

2x 80

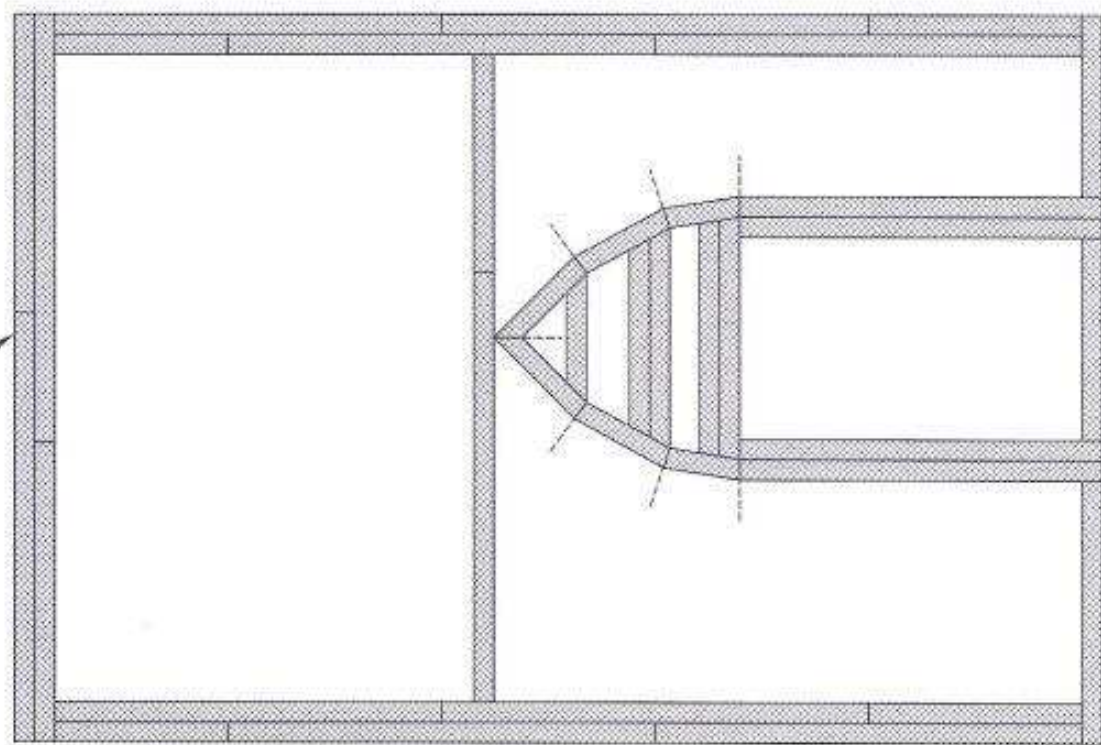

81

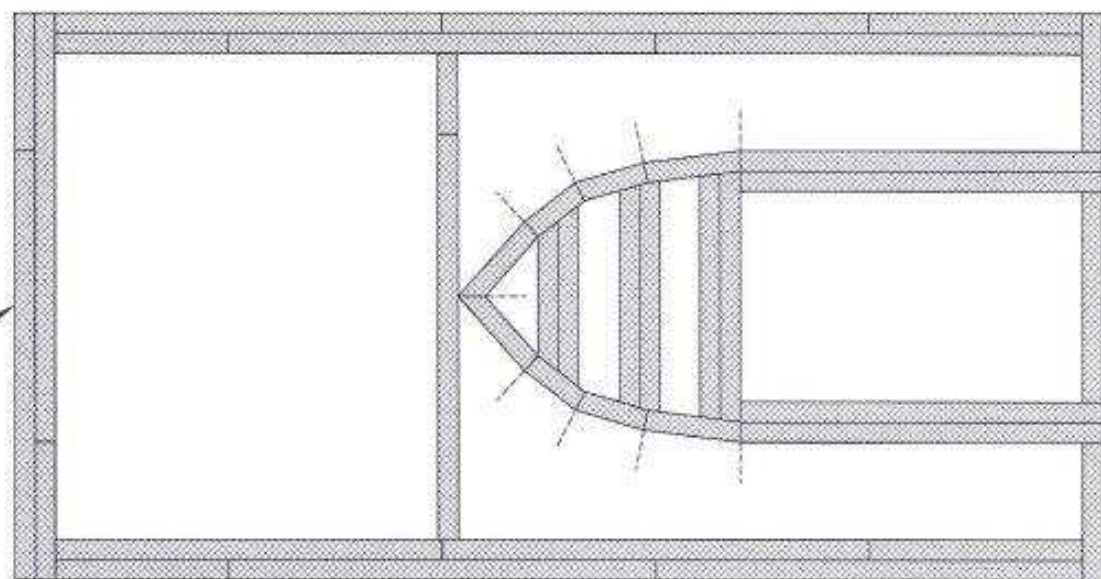

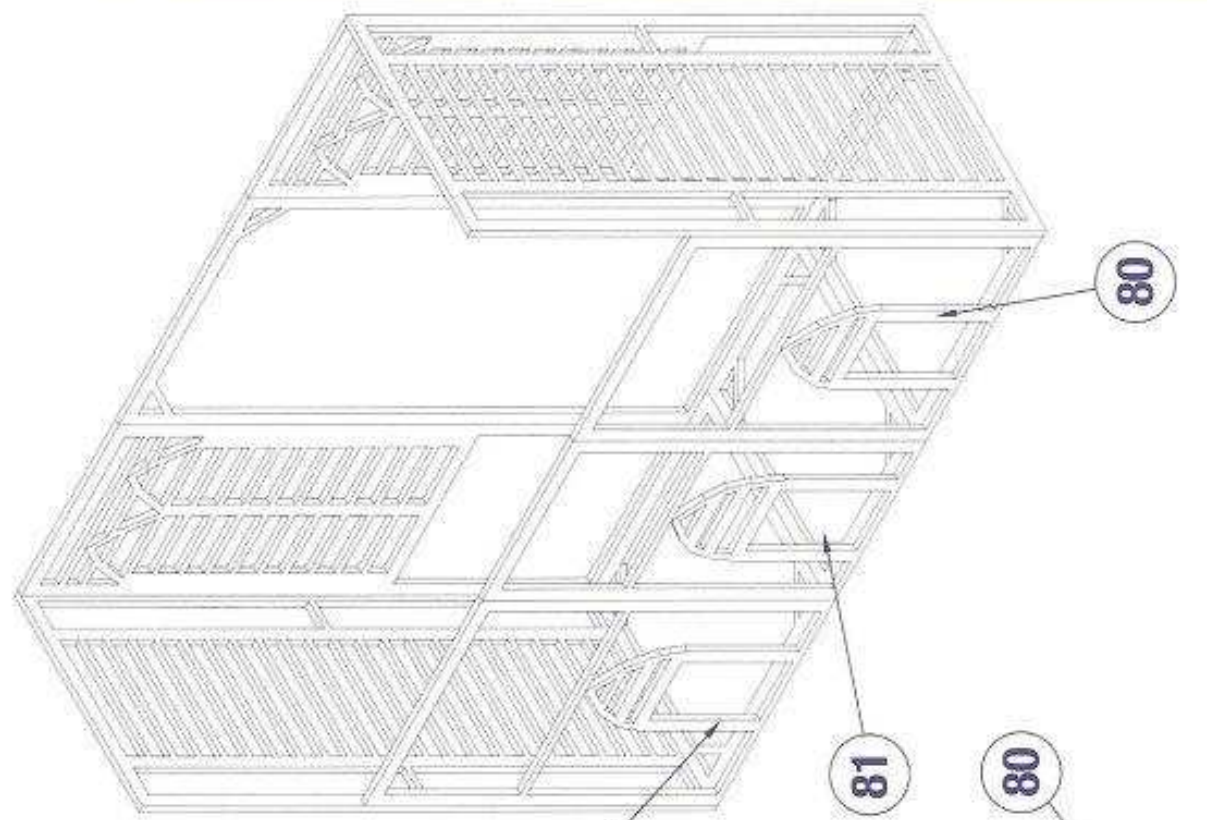
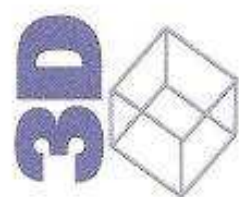

80

81

80

81

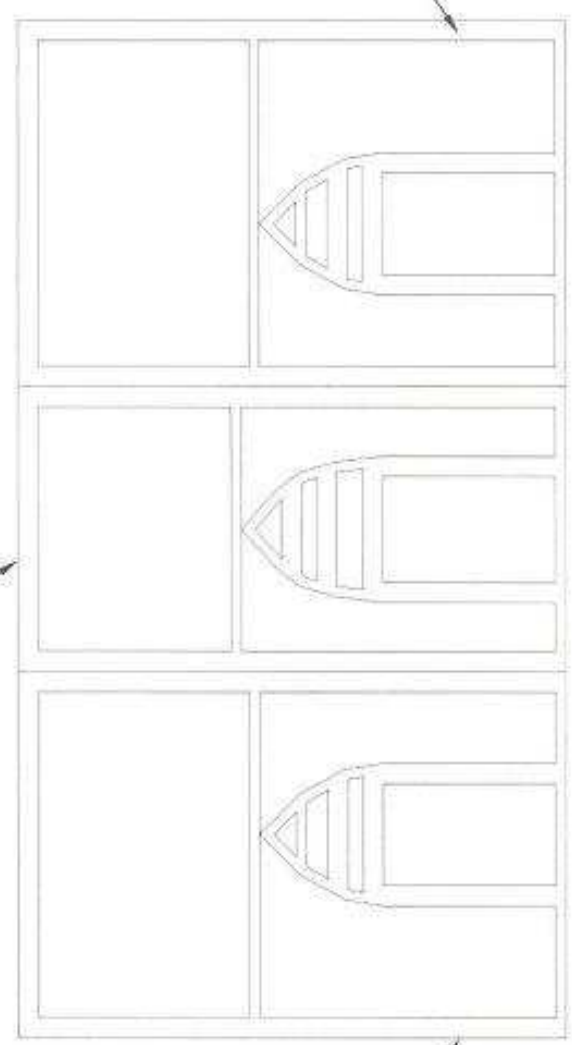

80

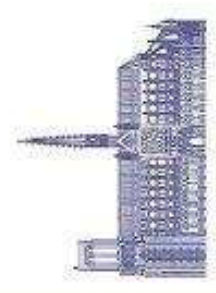

2x 82

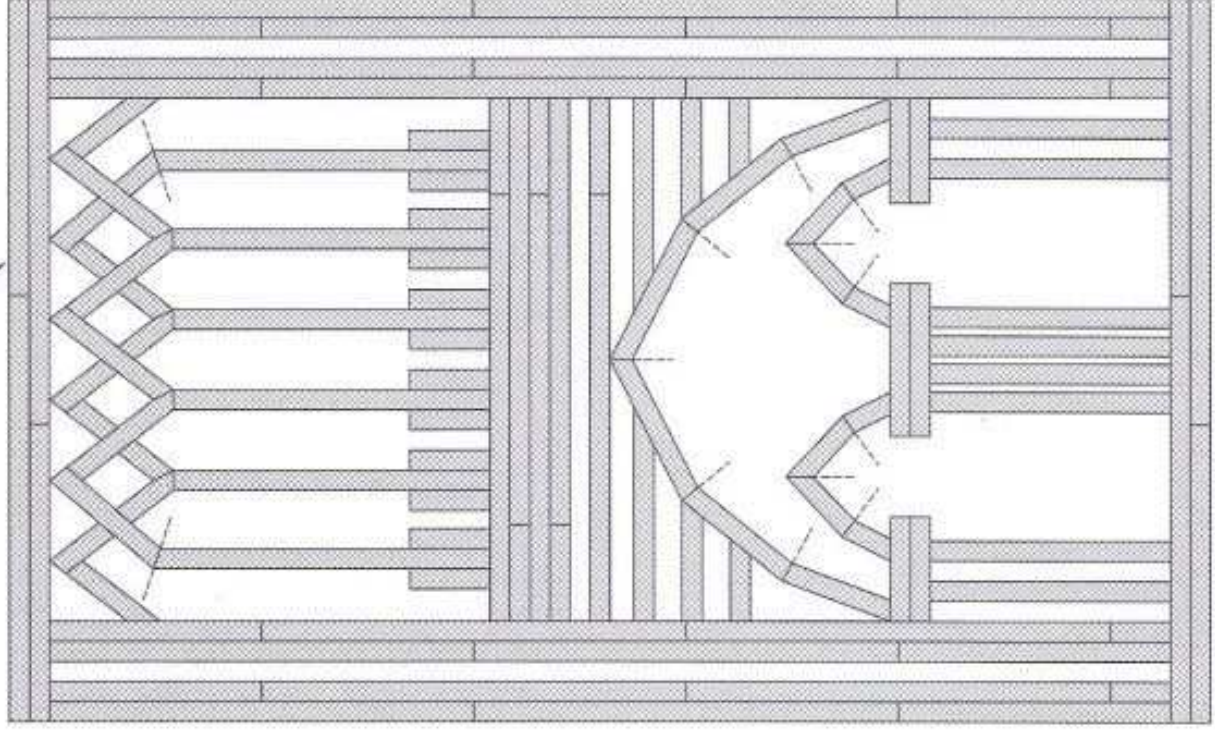

83

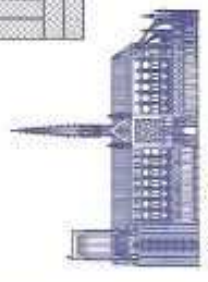
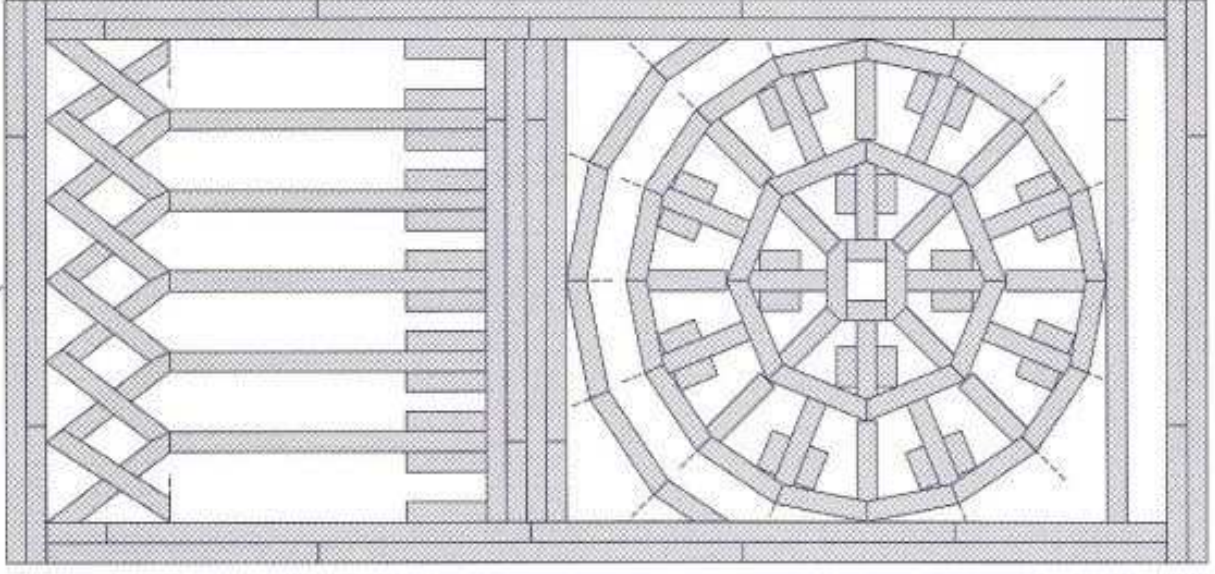

© 2008 Matchitecture, Inc.

www.matchitecture.com

MATCHITECTURE

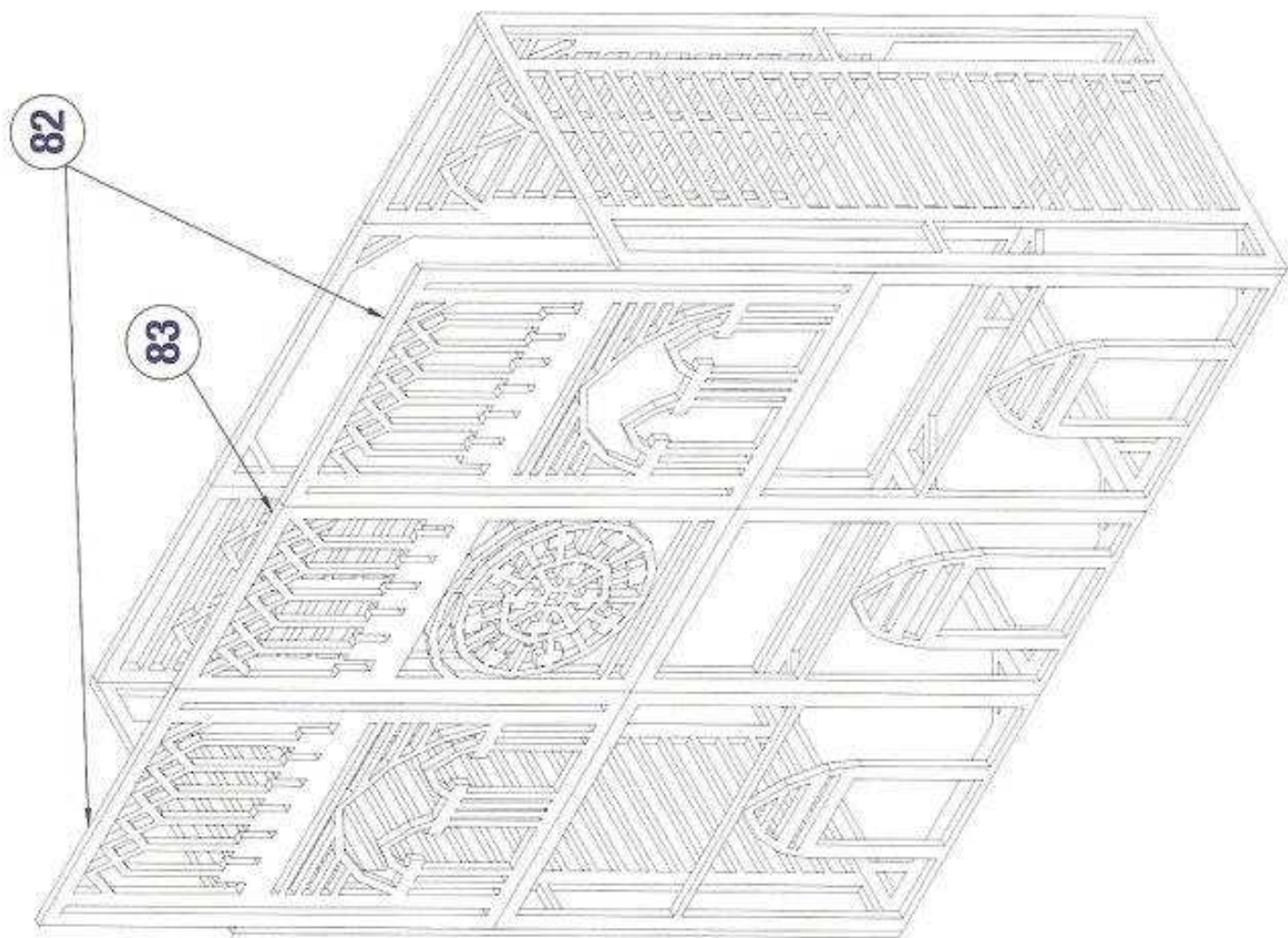
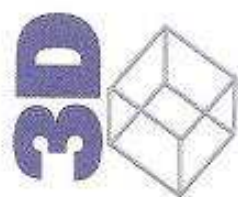

2x 84

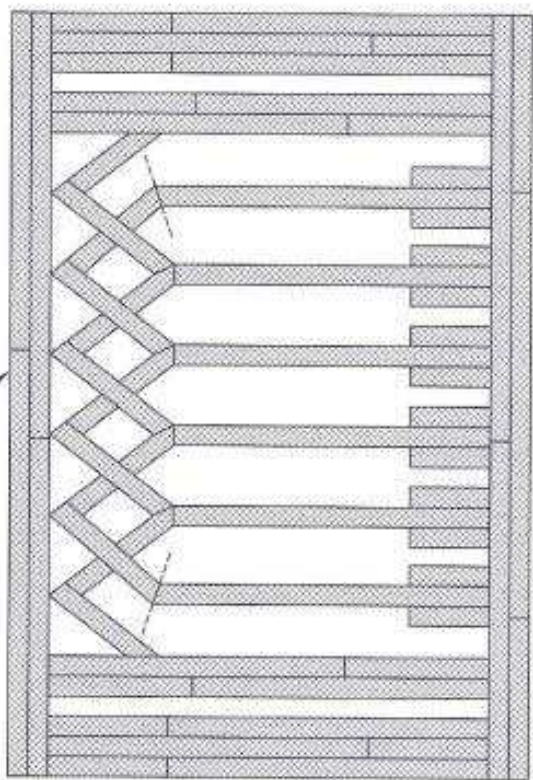

86

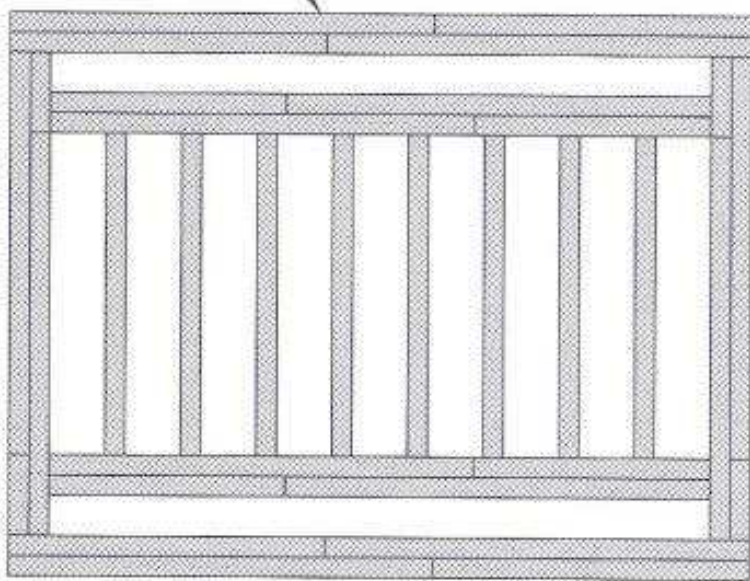

2x 85

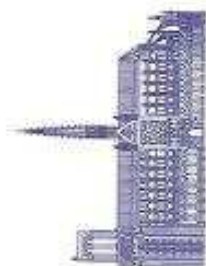
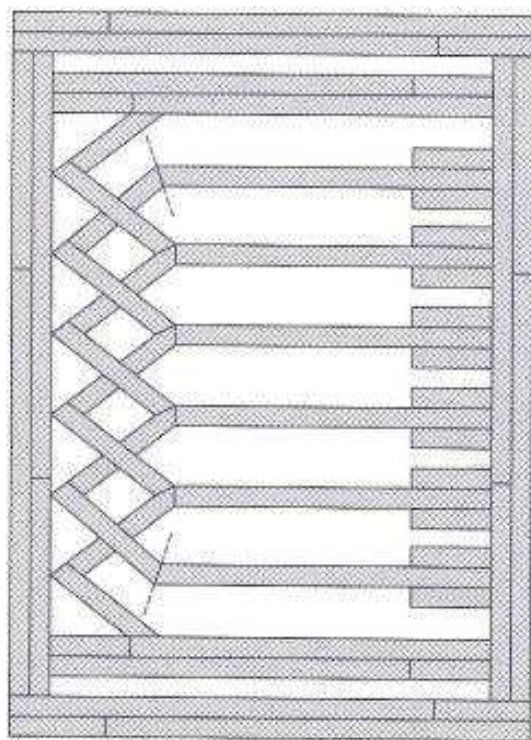

**3D** 

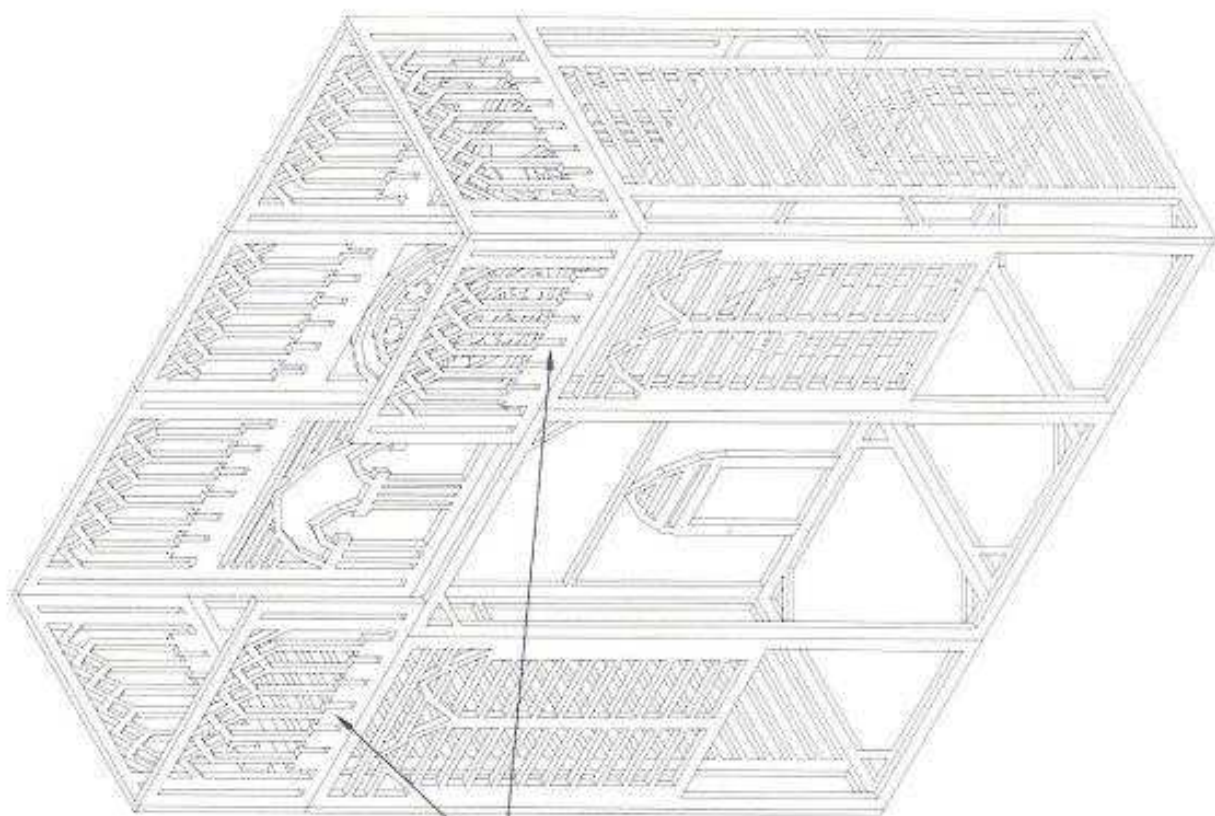

85

84

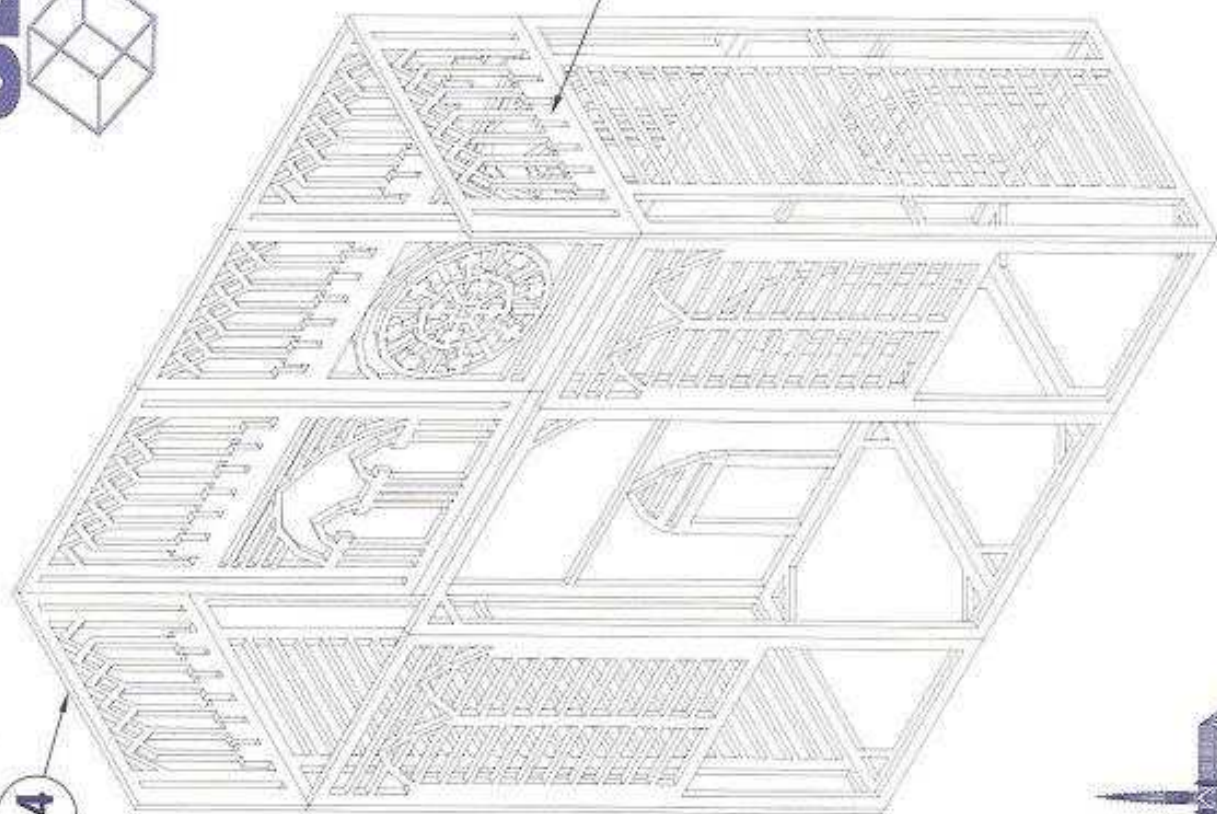

84



© 2006 Bejeux Inc.

**3D**

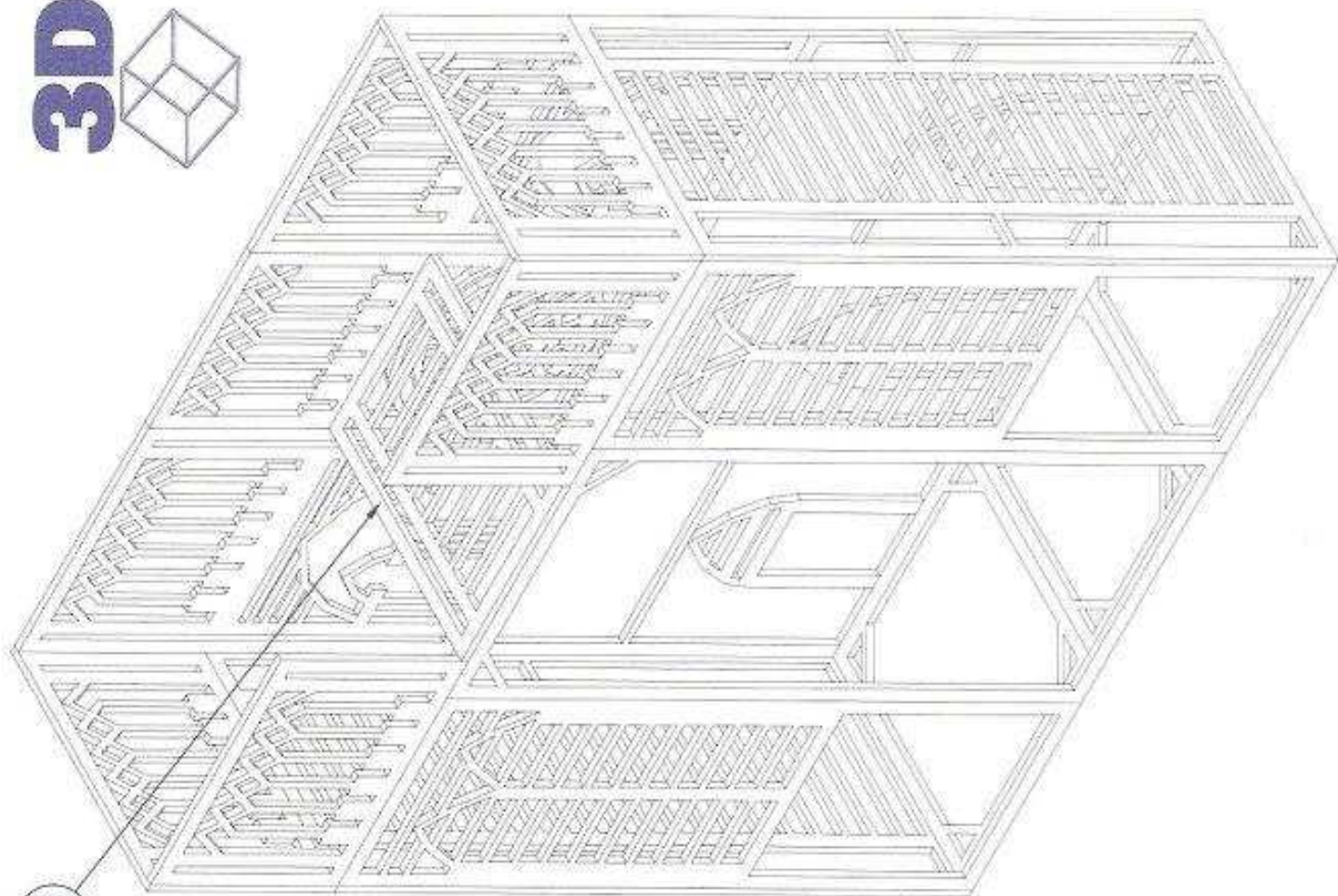

86

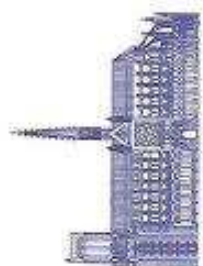

© 2006 Bojoux Inc.

[www.matchitecture.com](http://www.matchitecture.com)

**MATCHITECTURE**

72 / 106

**3D**



**2x 87**

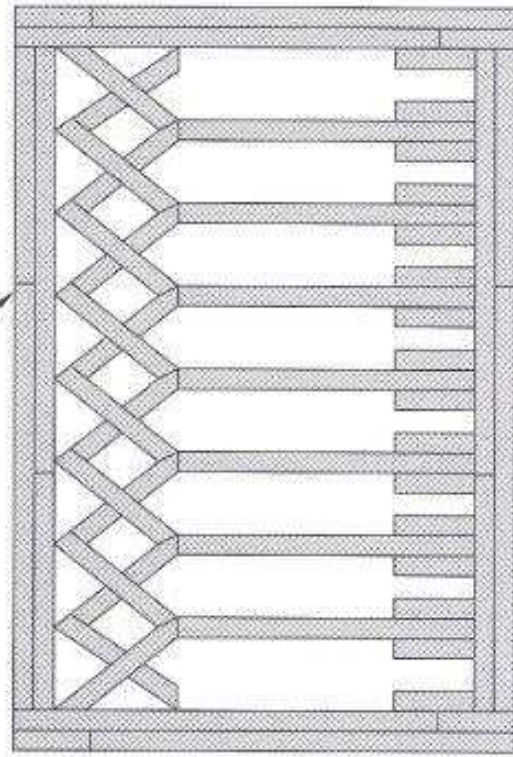

**87**

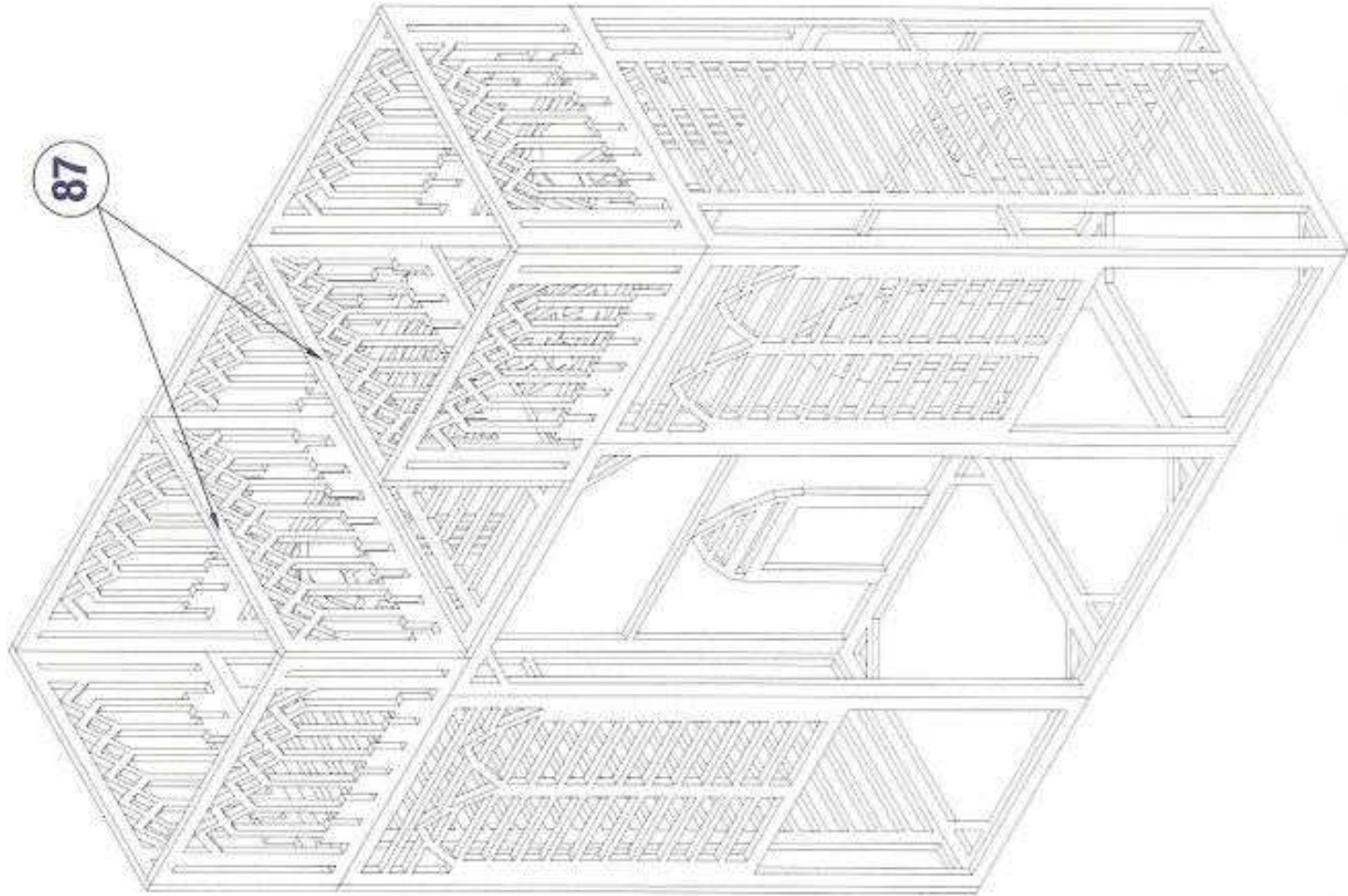

© 2016 Bepus Inc.

[www.matchitecture.com](http://www.matchitecture.com)

**MATCHITECTURE**

4x 88

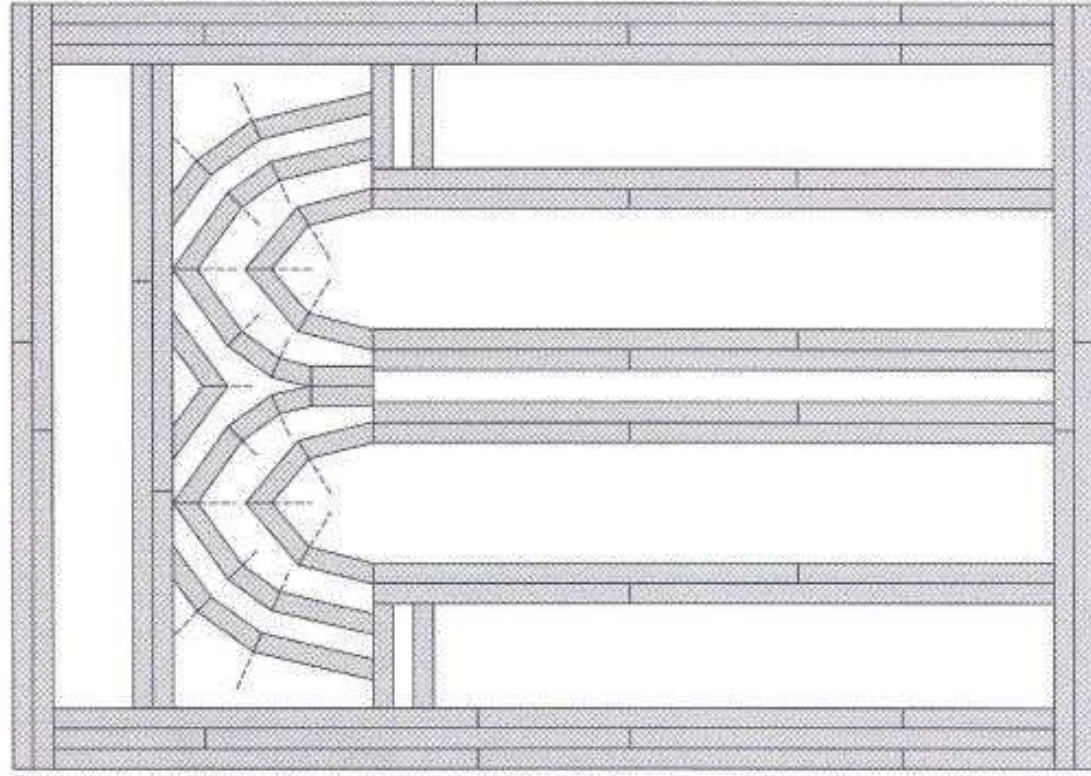
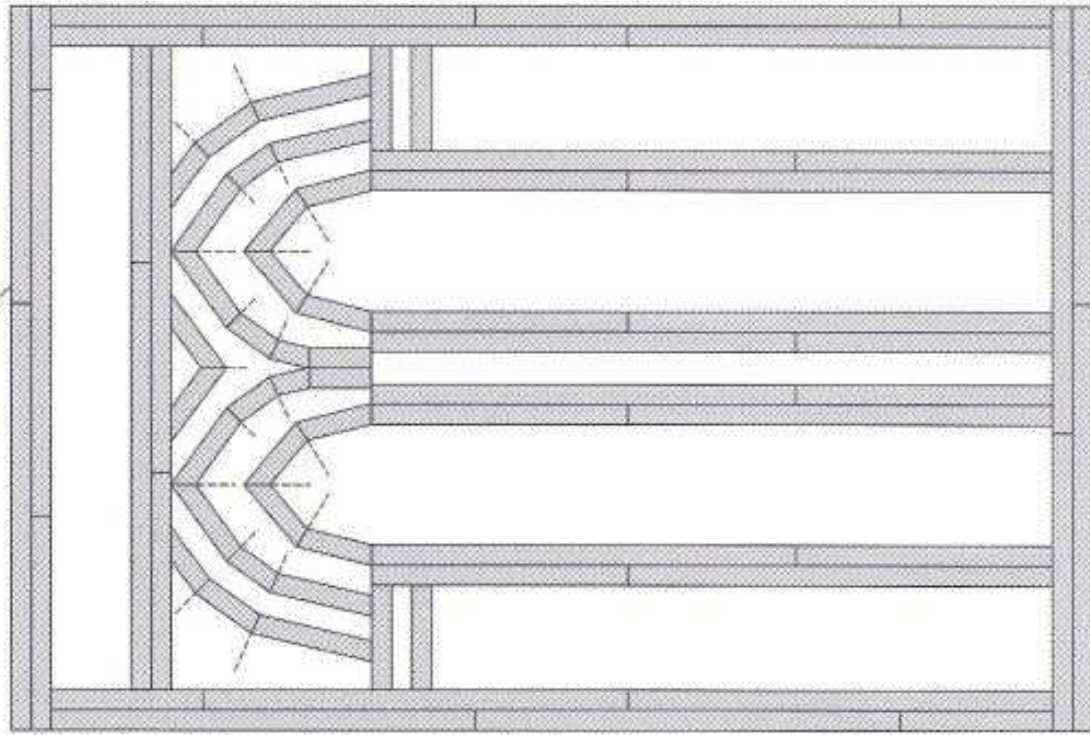

4x 89

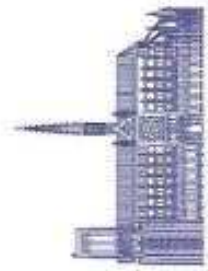

© 2006 Boreux Inc.

www.matchitecture.com

MATCHITECTURE

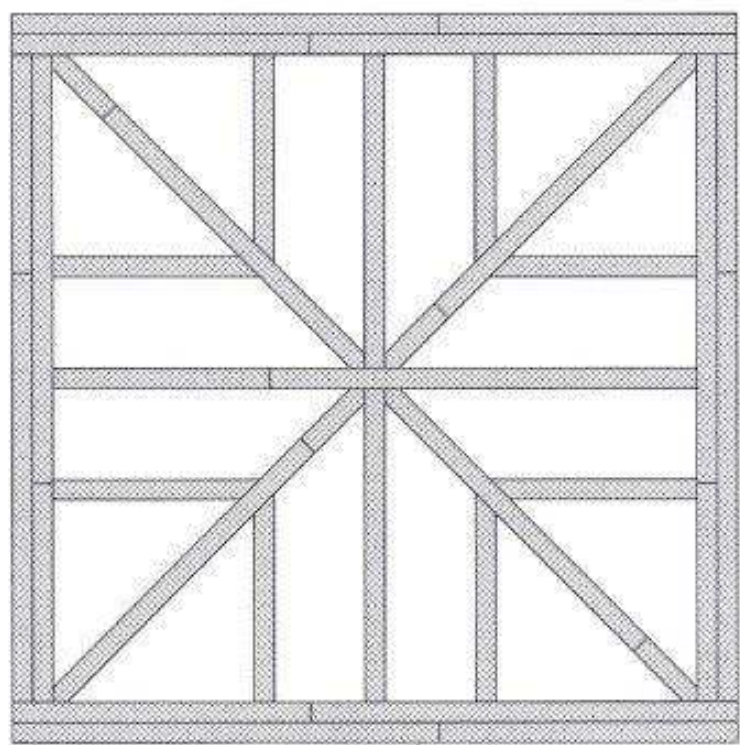
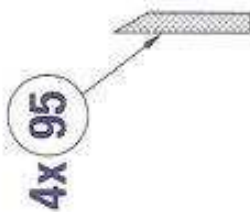
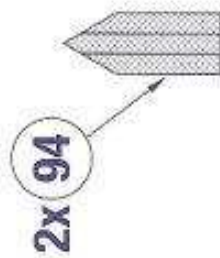
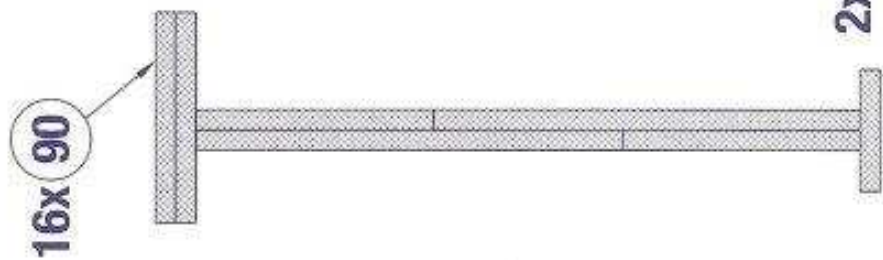
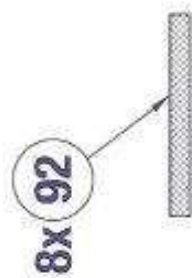
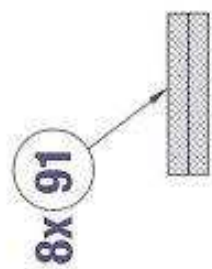

3D

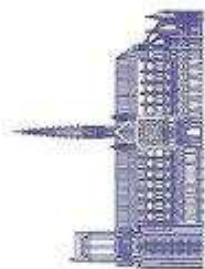
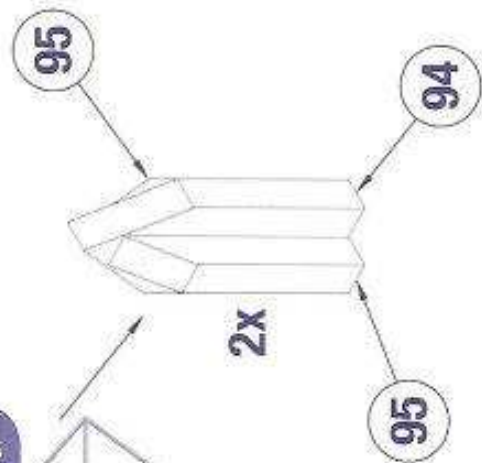

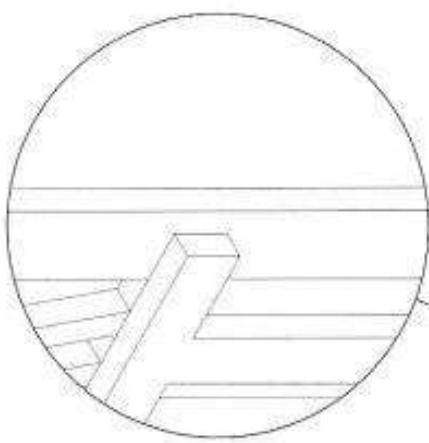

90

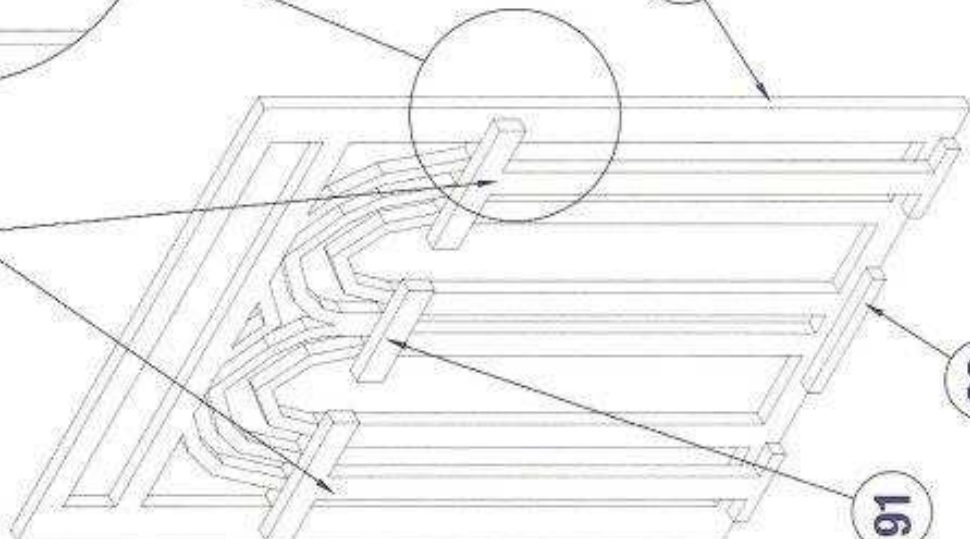

89

91

92

4x

3D 

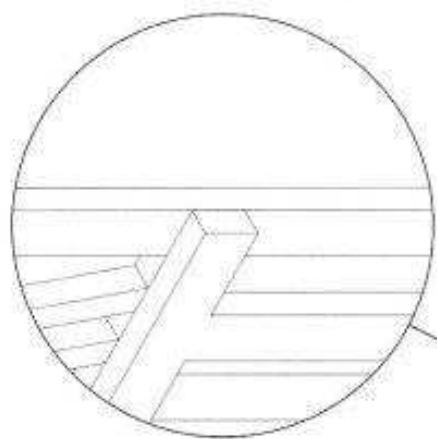

90

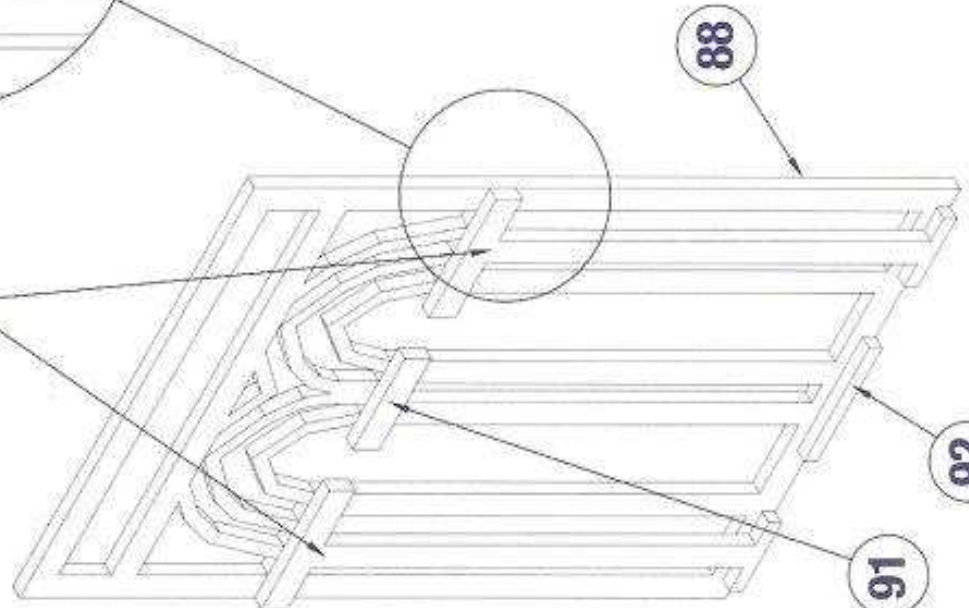

88

91

92

4x

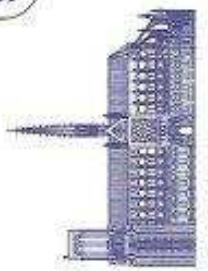

© 2008 Bojeux Inc.

www.matchitecture.com

MATCHITECTURE

**3D** 

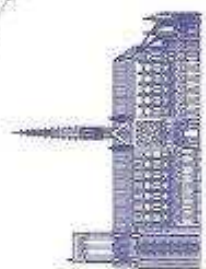
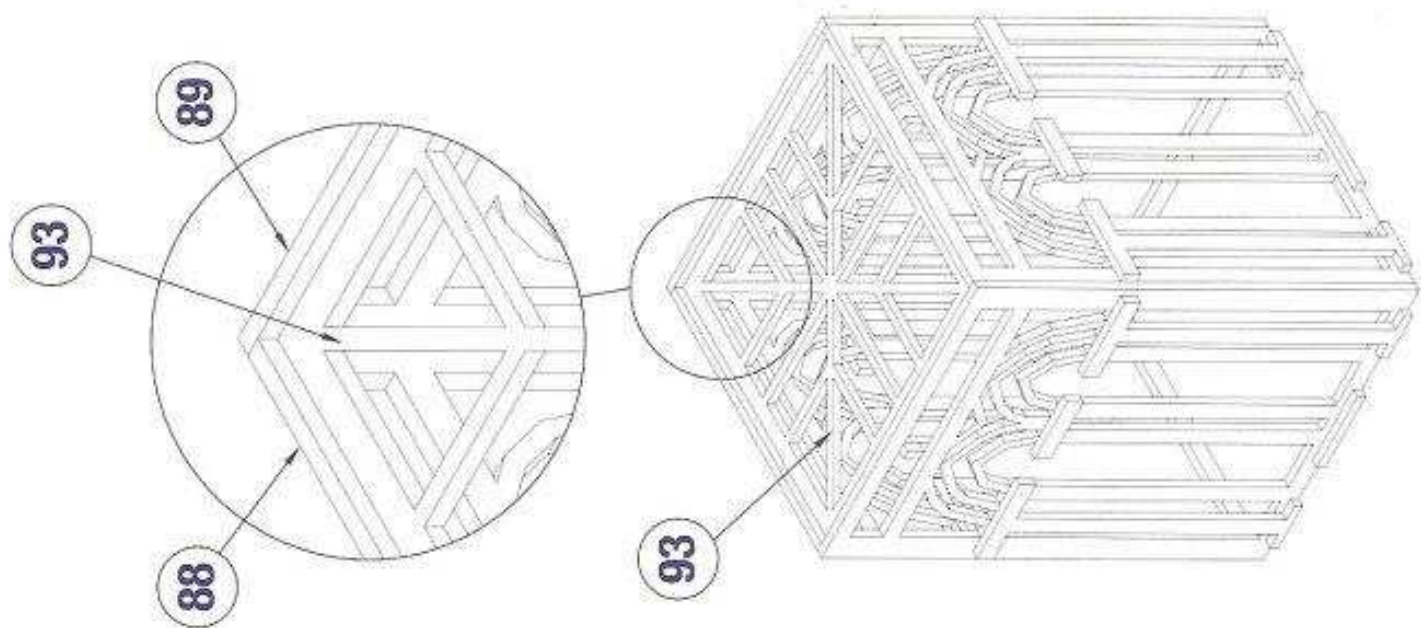
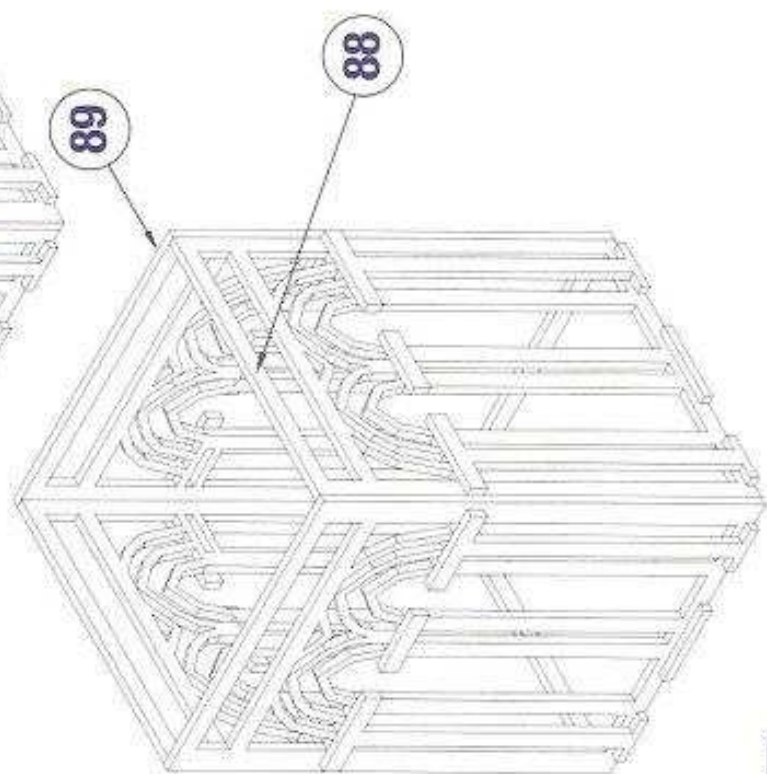
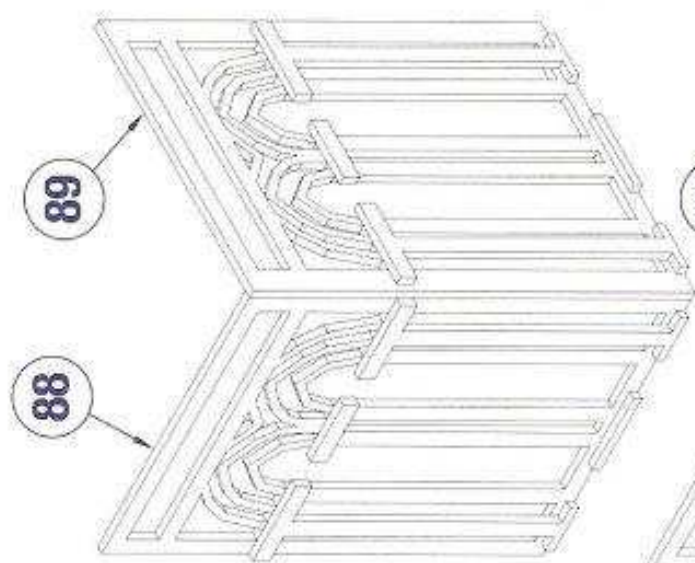

94

94

3D

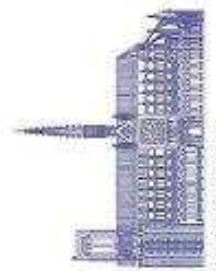
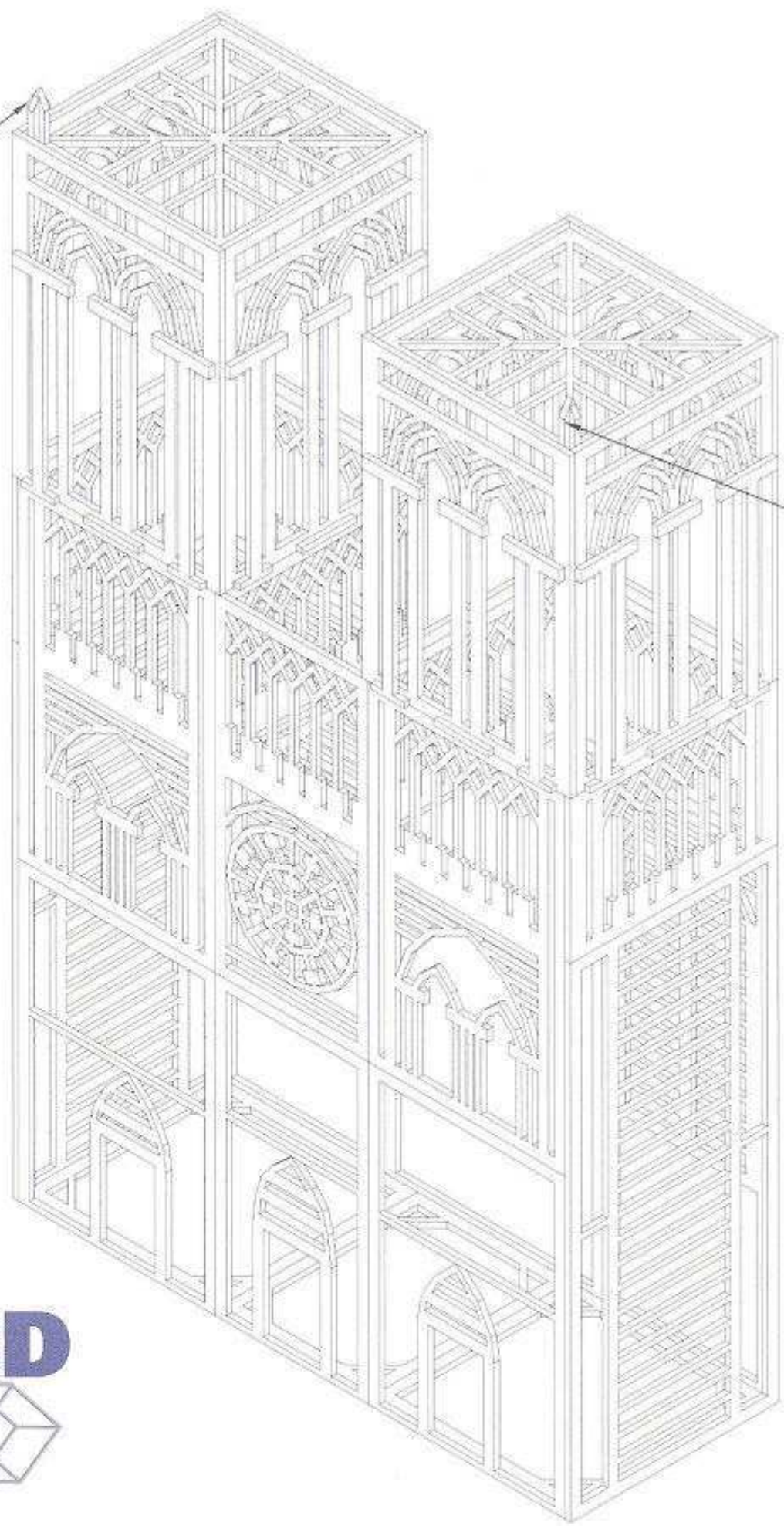

96

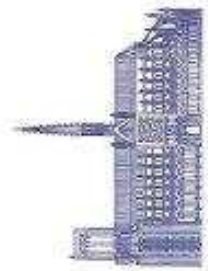
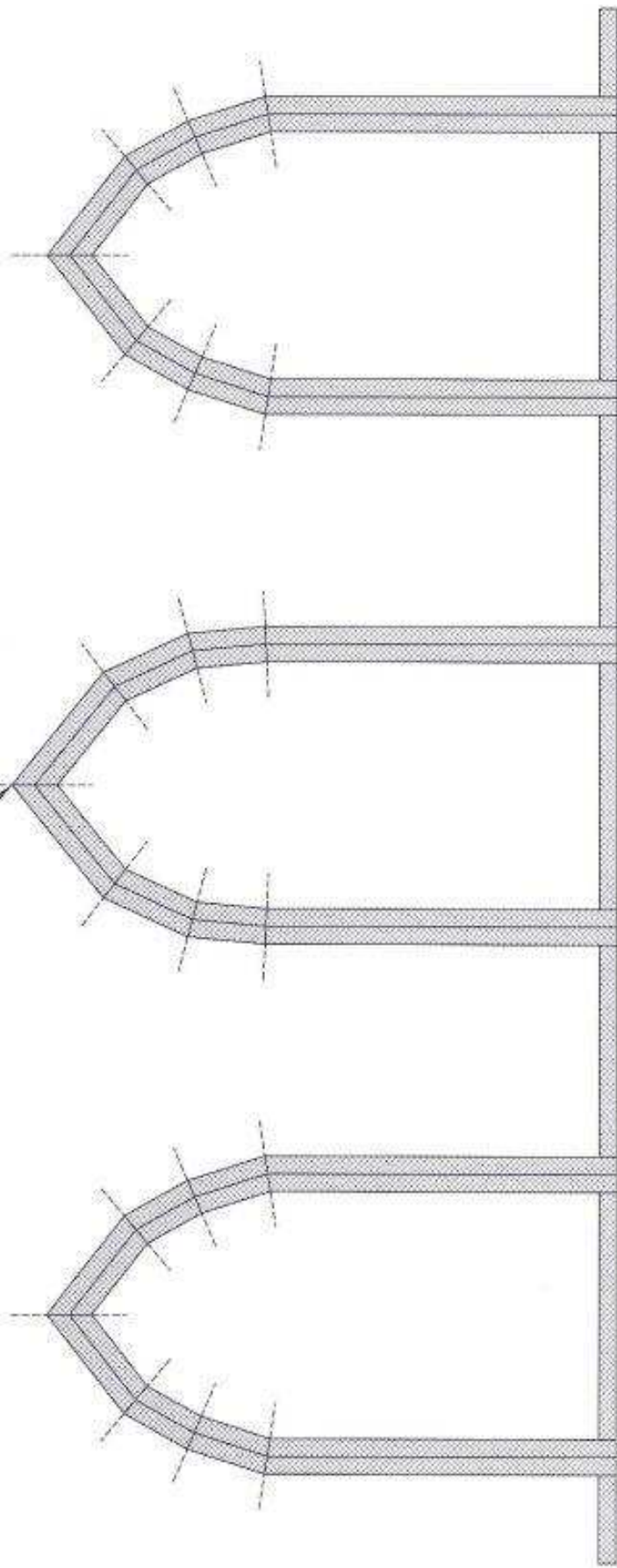

97

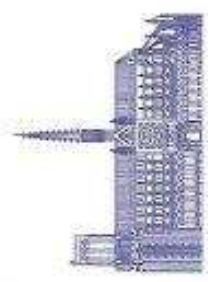
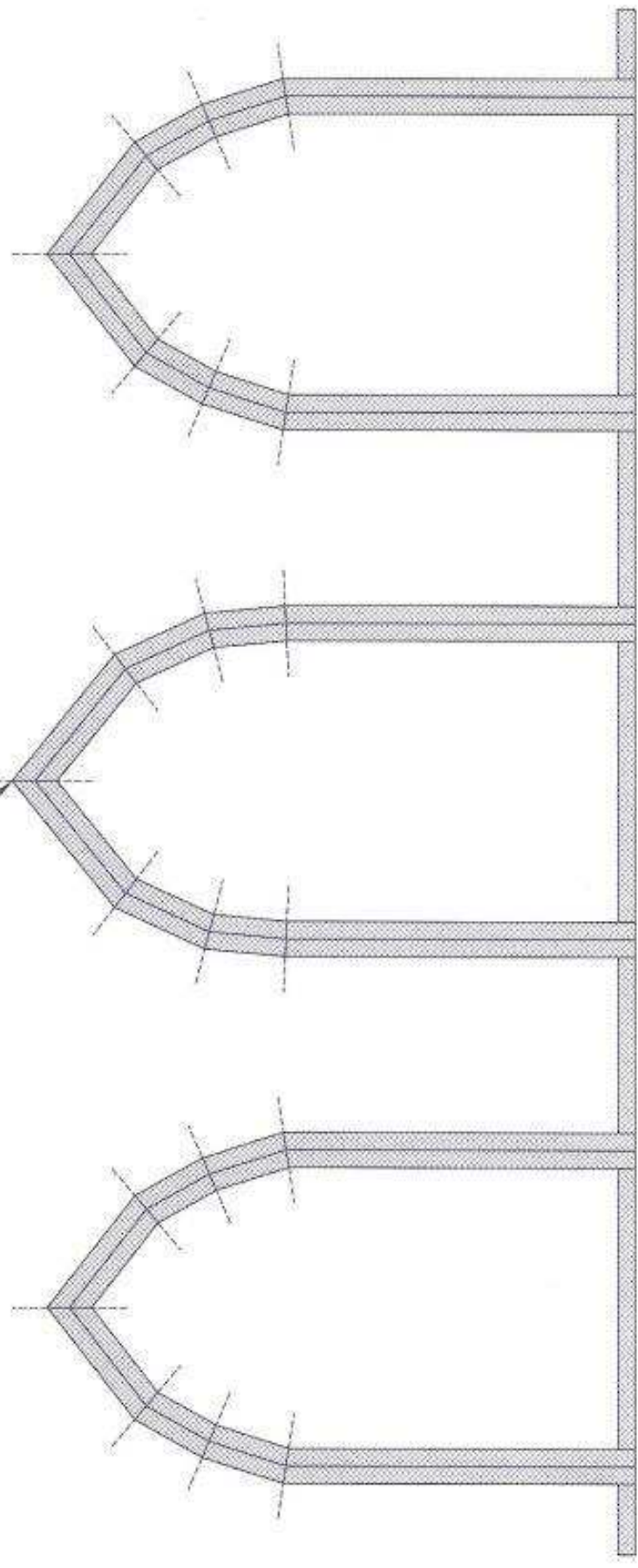

98

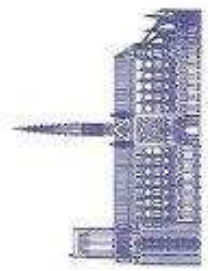
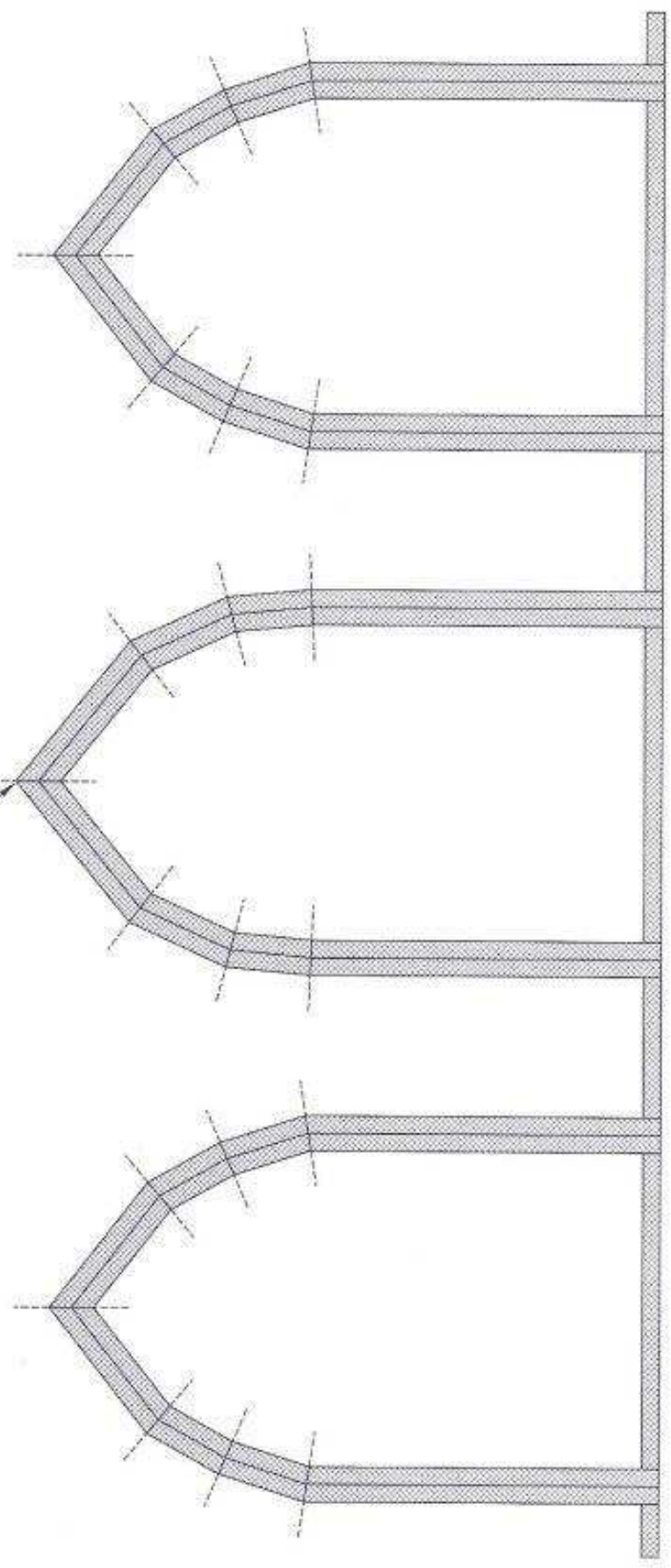

66

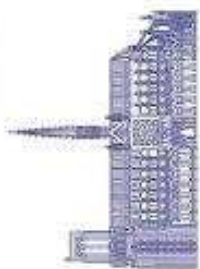
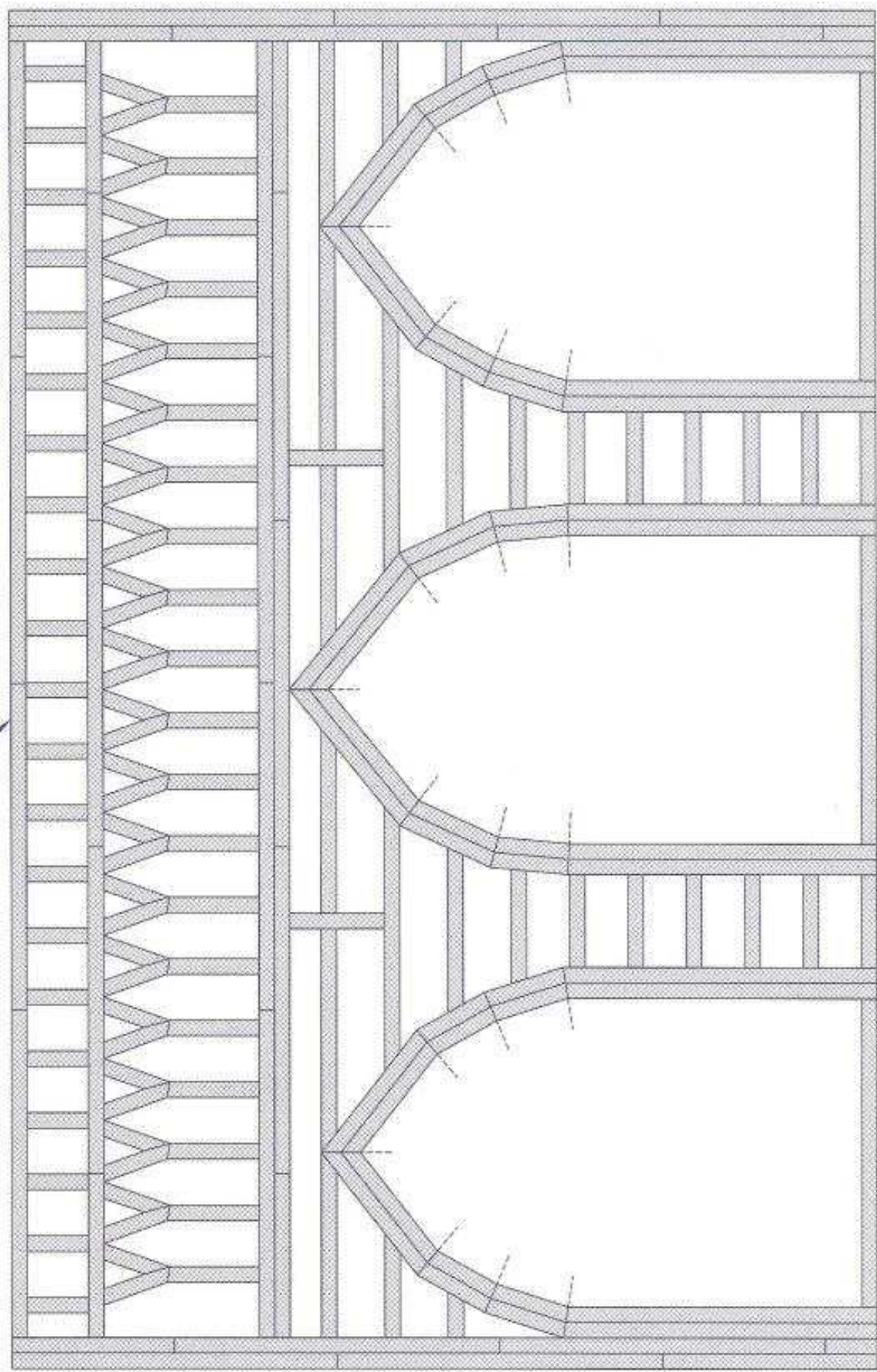

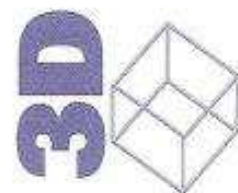
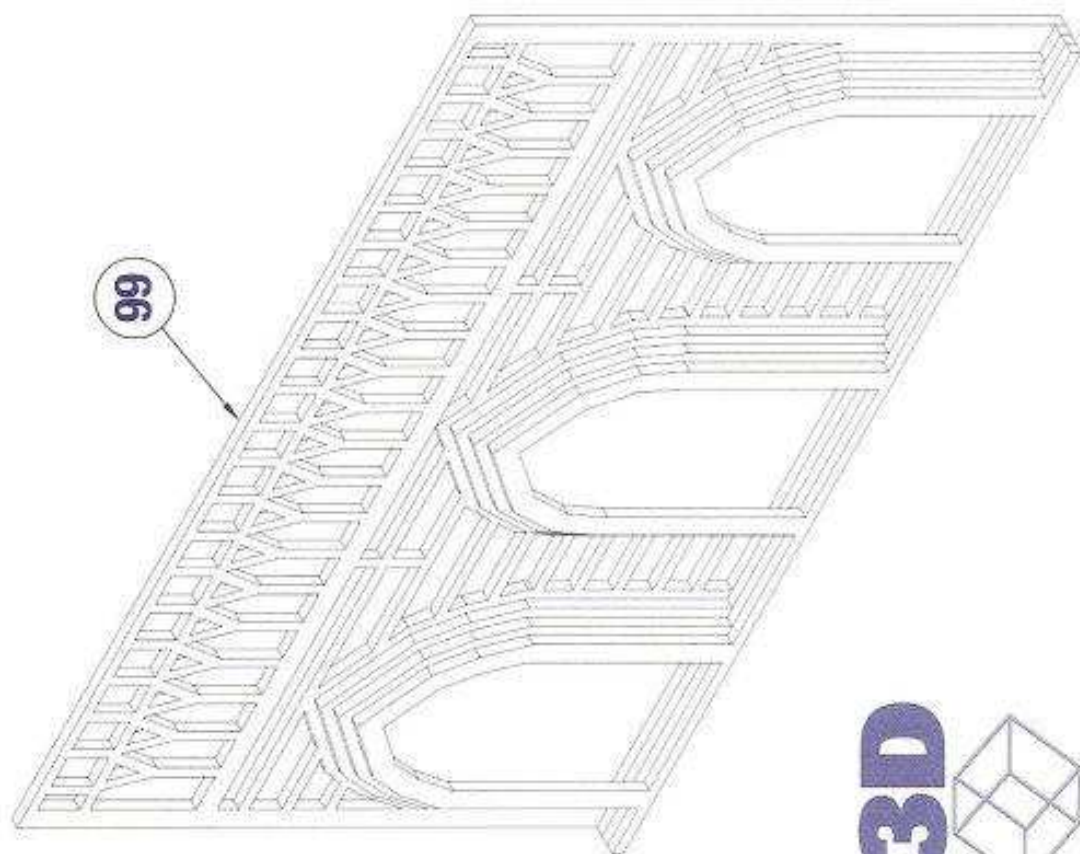
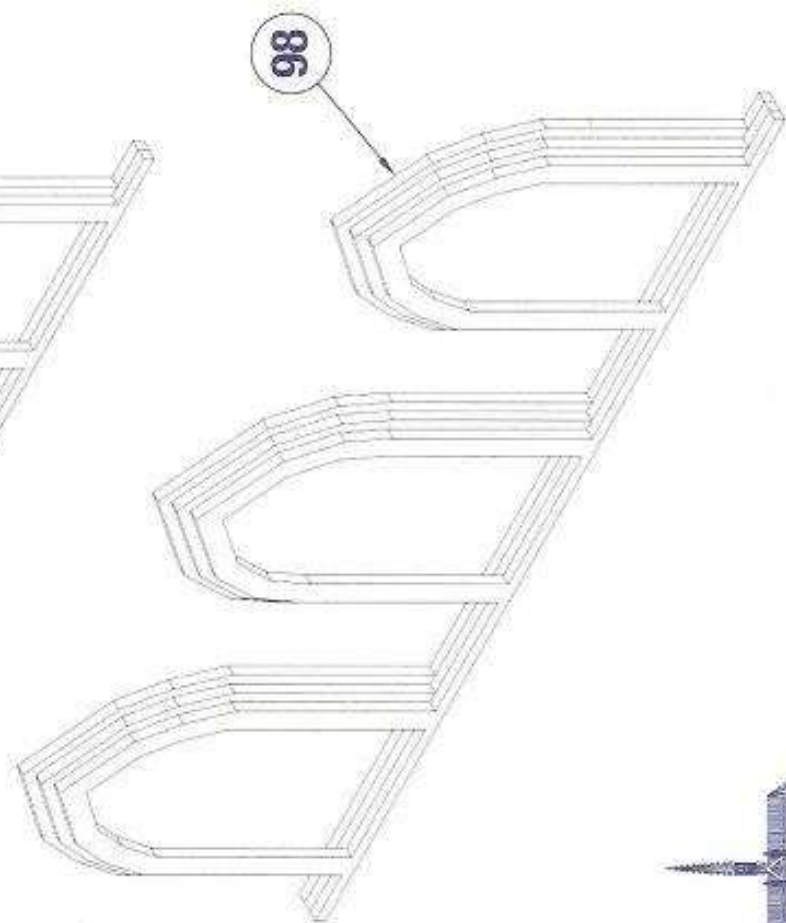
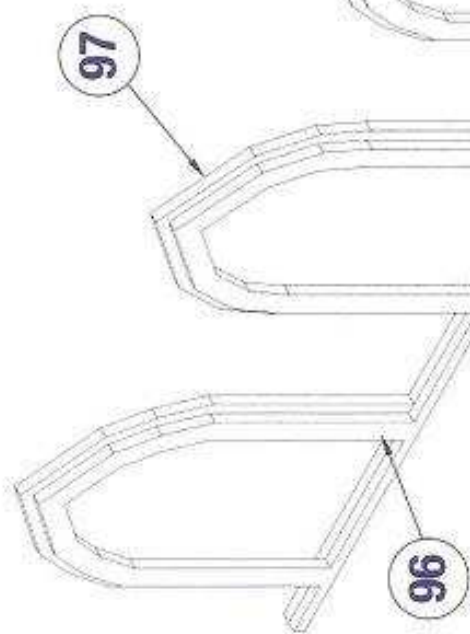

3D

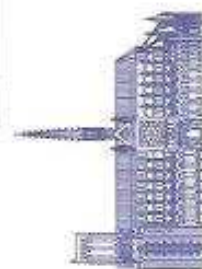
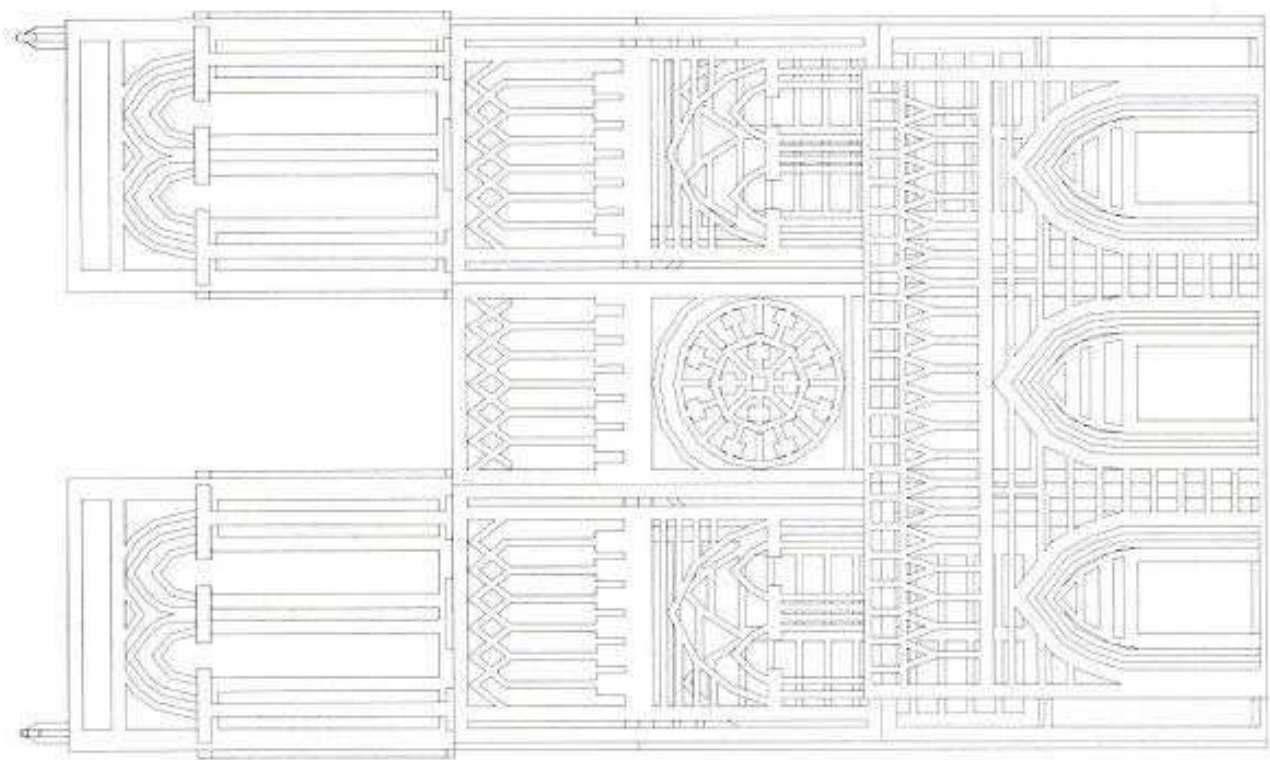
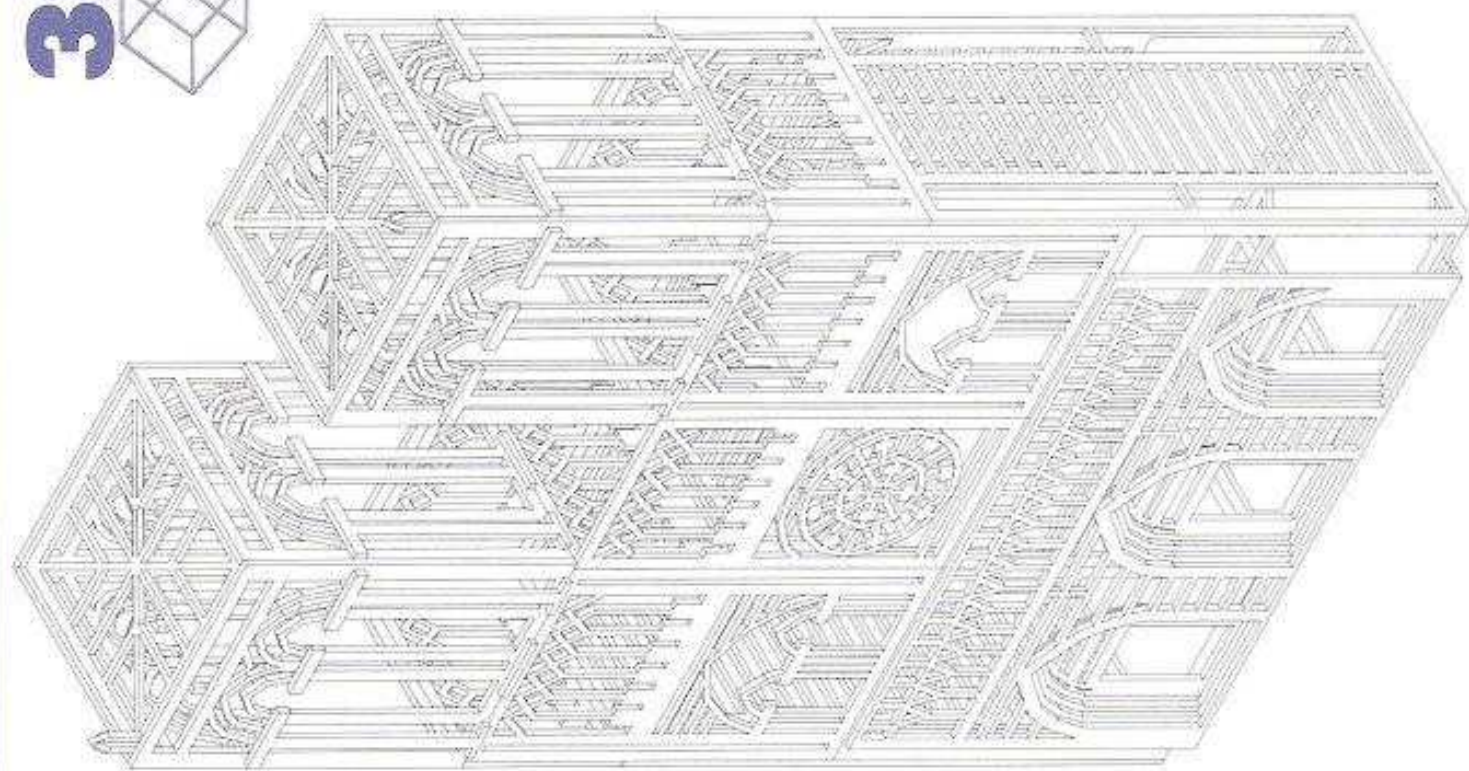

© 2005 Borex Inc.

[www.matchitecture.com](http://www.matchitecture.com)

MATCHITECTURE

84 / 105

16x100

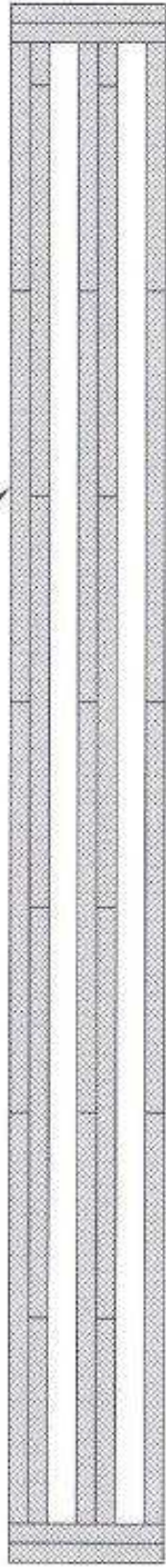

8x101

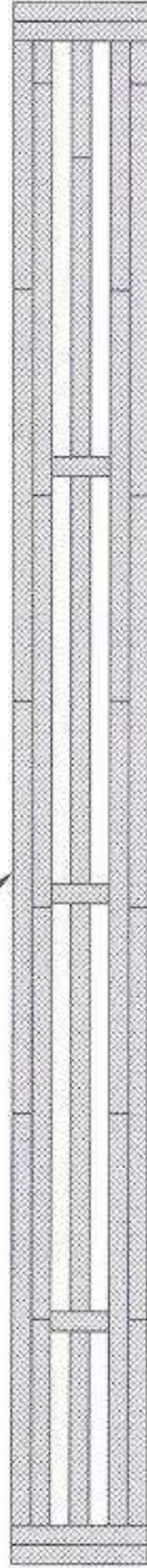

16x102

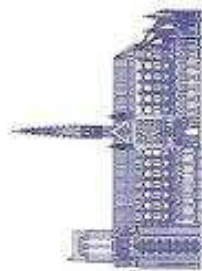
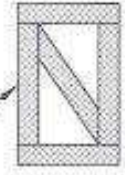

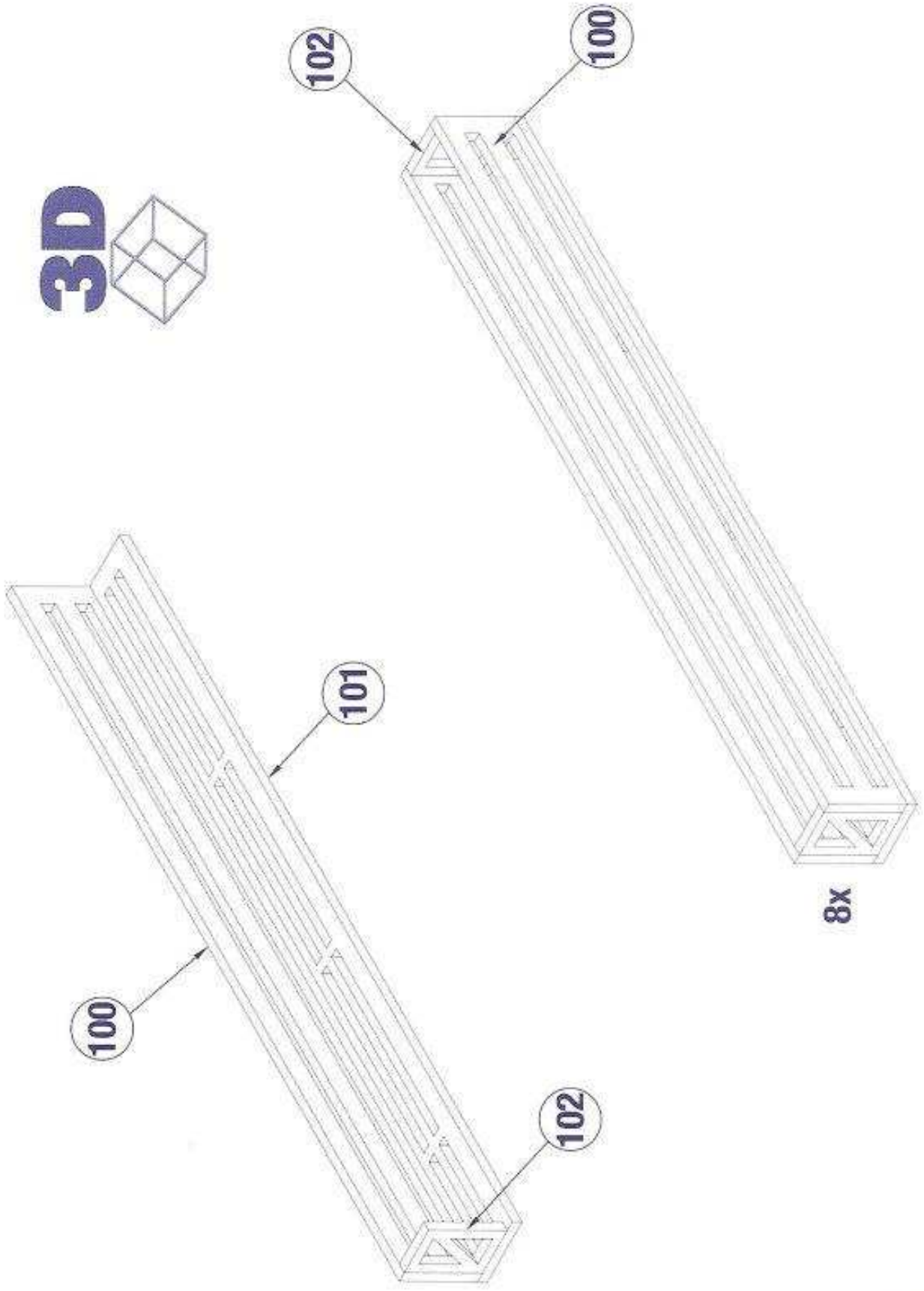

8x



© 2006 Baycon Inc.

[www.matchitecture.com](http://www.matchitecture.com)

MATCHITECTURE

86 / 105

**3D**

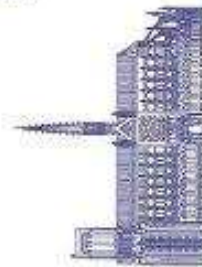
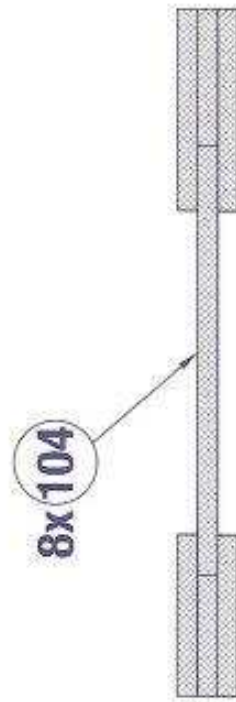
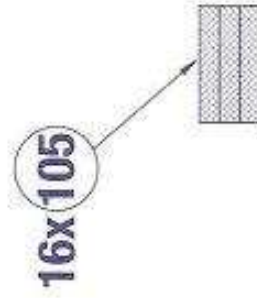
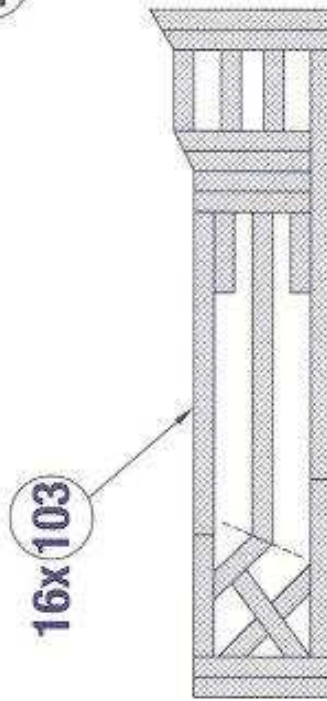
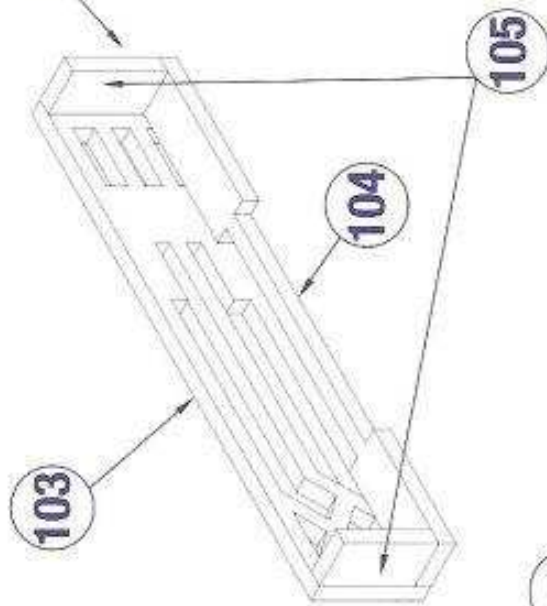
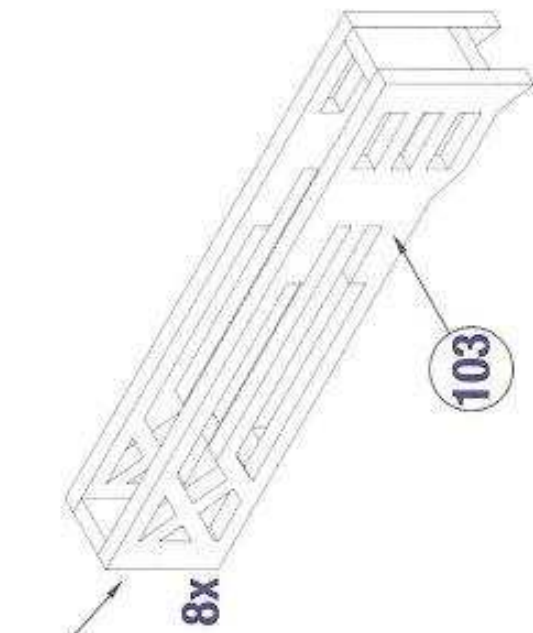

**3D** 

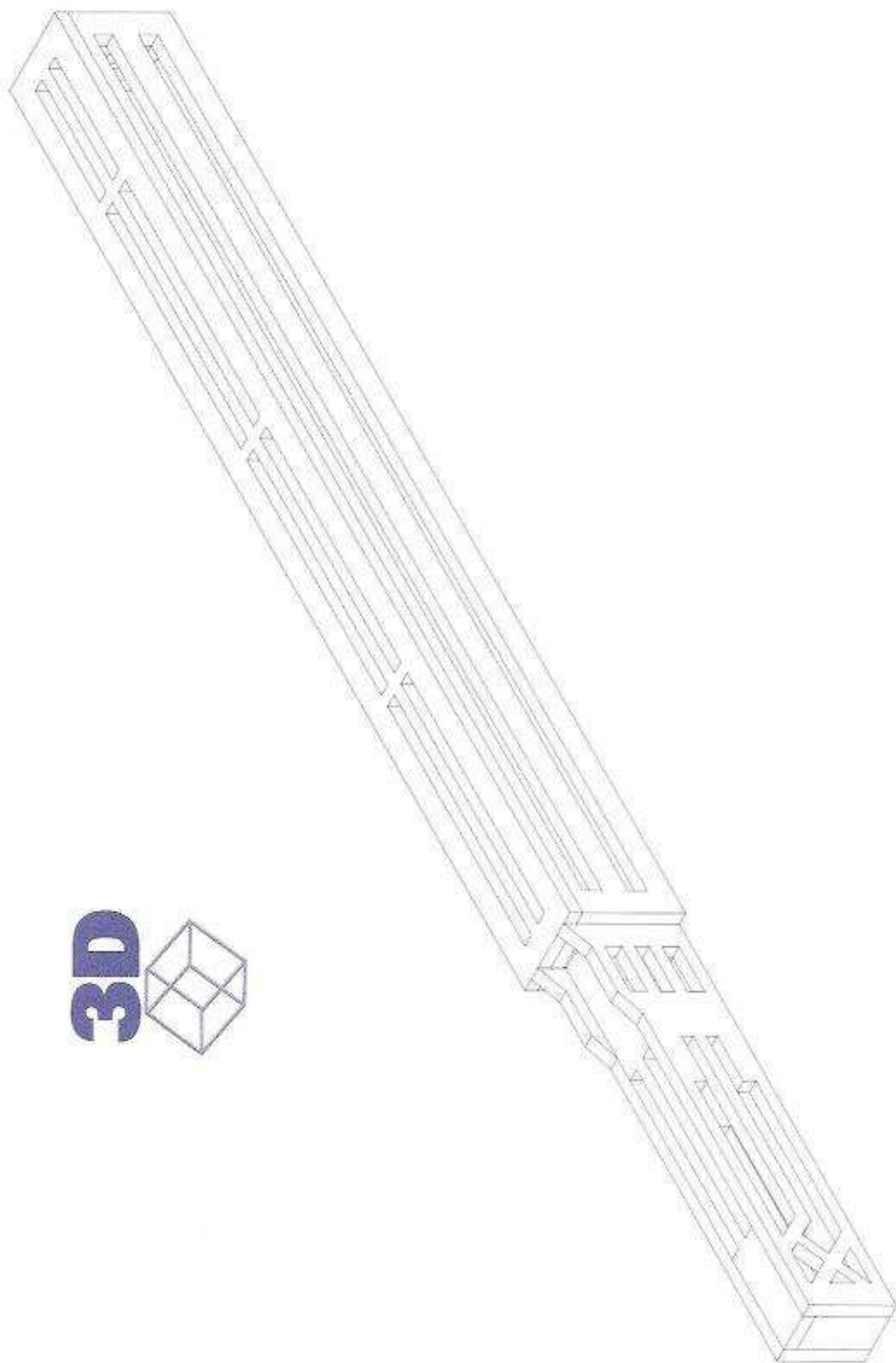

**8x**

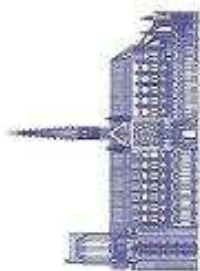

© 2006 Bejeux Inc.

[www.matchitecture.com](http://www.matchitecture.com)

**MATCHITECTURE.**

88 / 105

**3D**

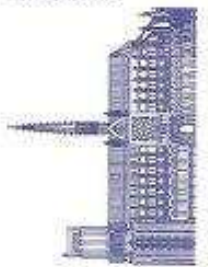
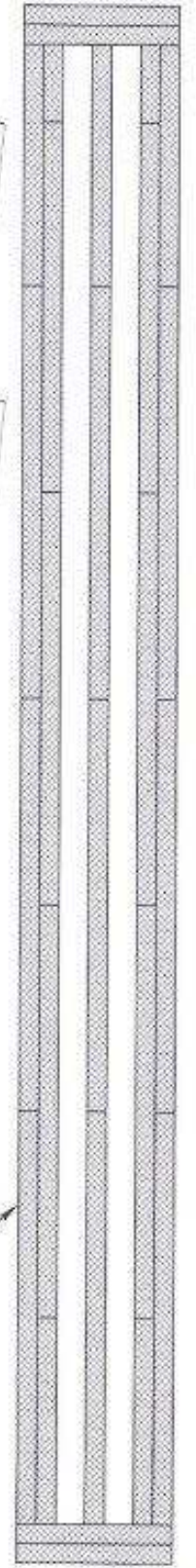
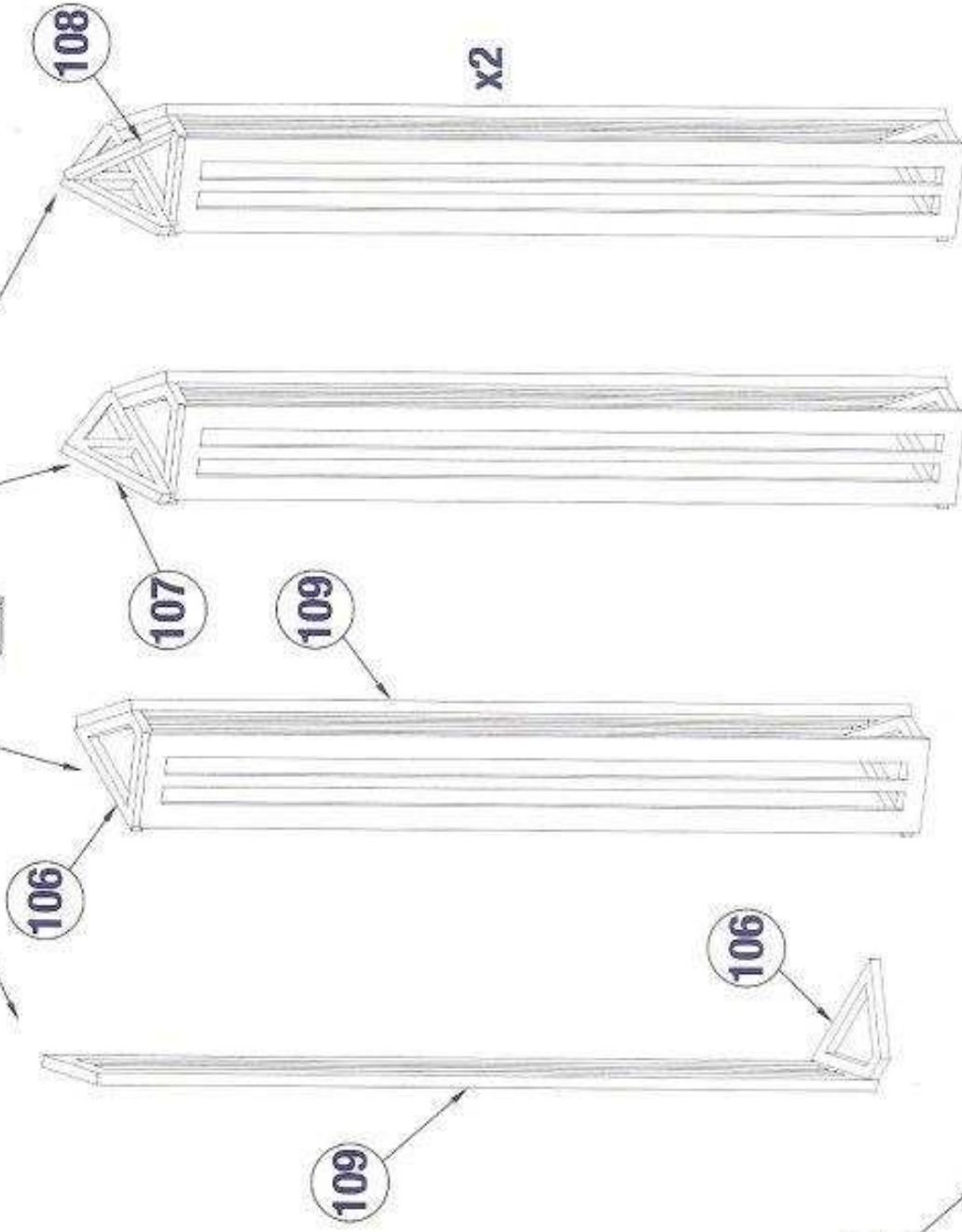
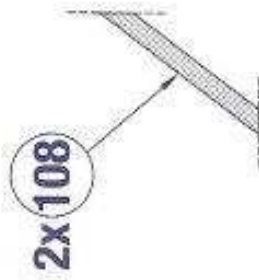
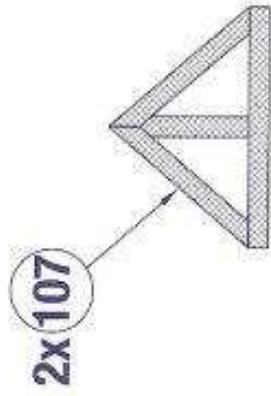
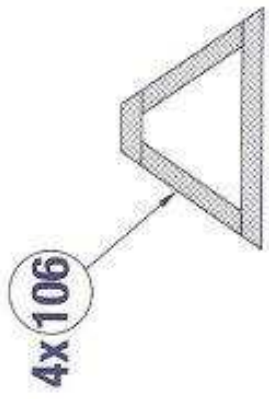

**3D**

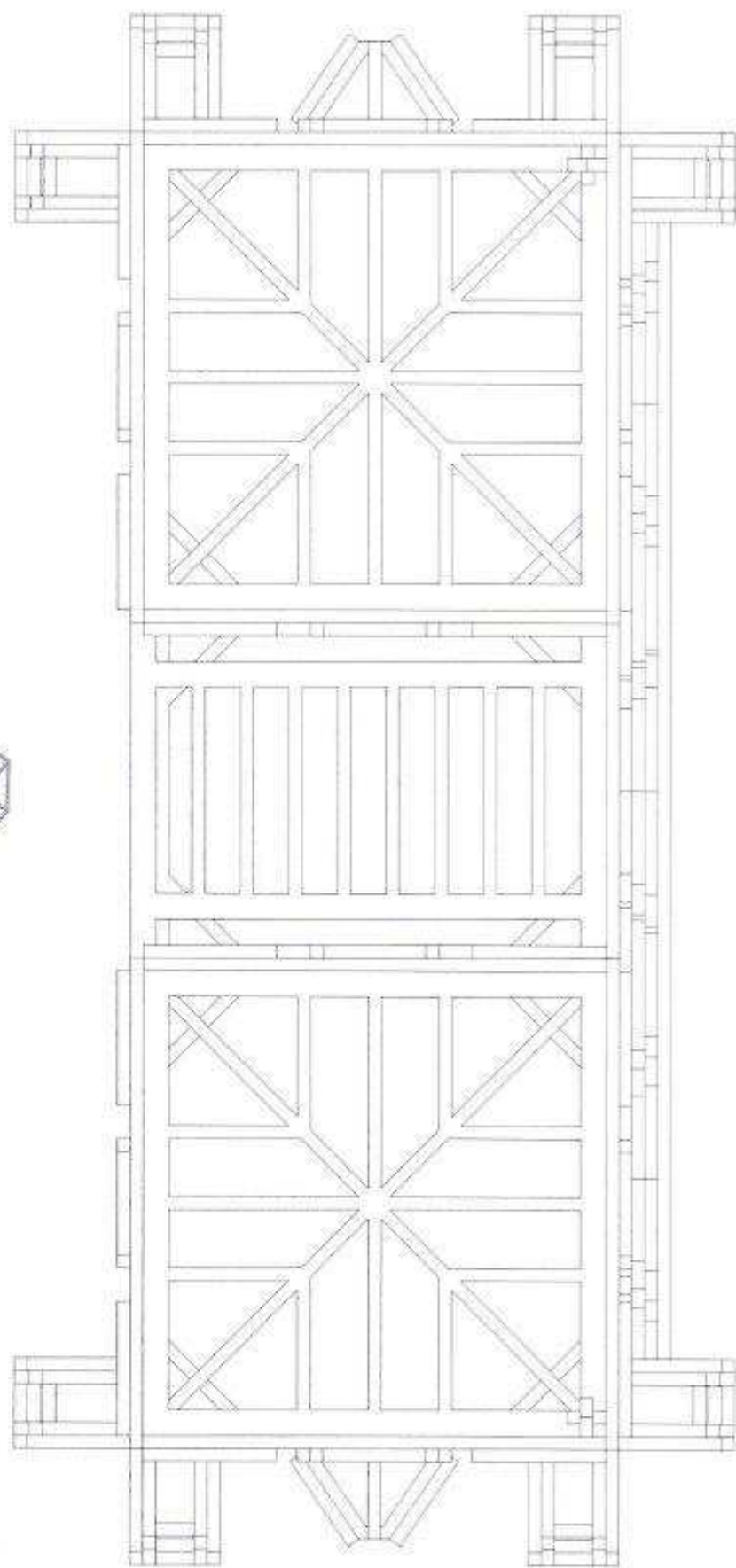

© 2006 Bigoux Inc.

[www.matchitecture.com](http://www.matchitecture.com)

**MATCHITECTURE**

90 / 105

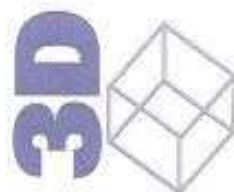
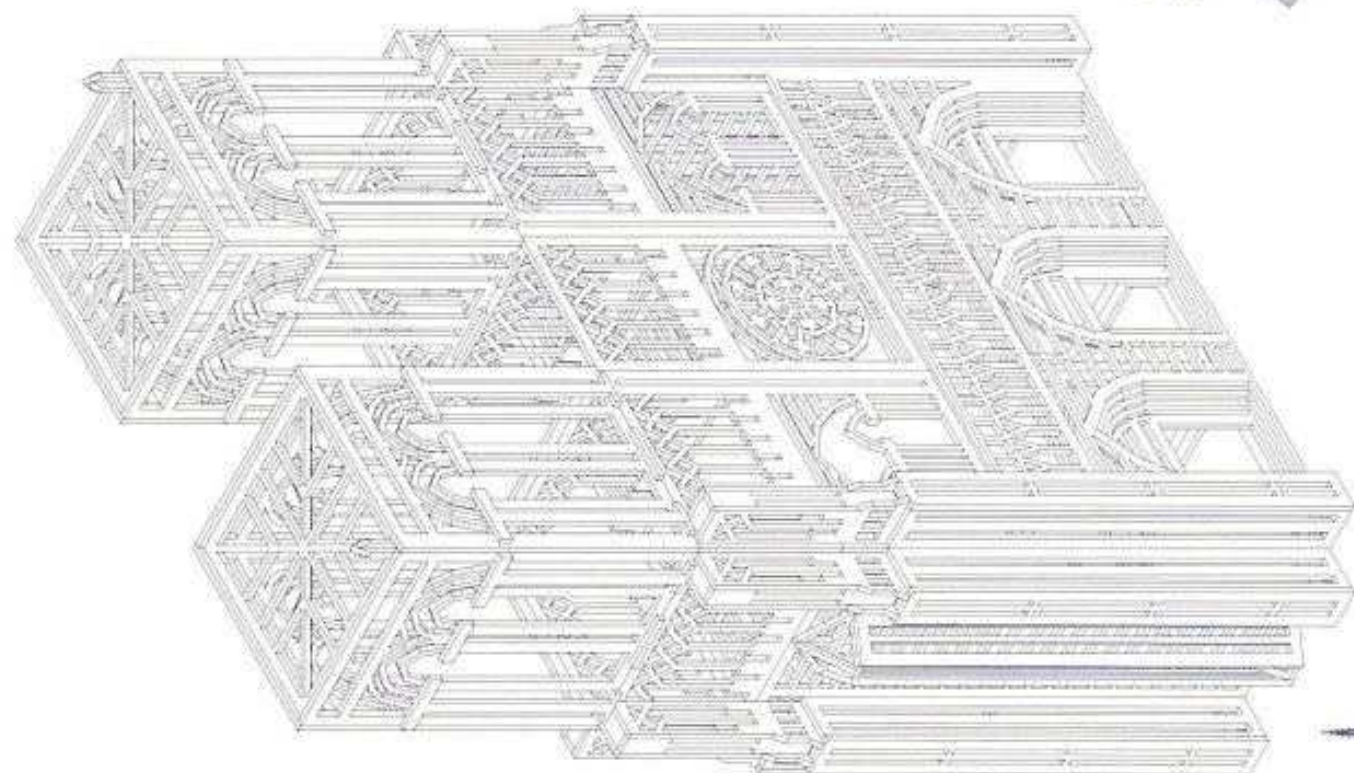
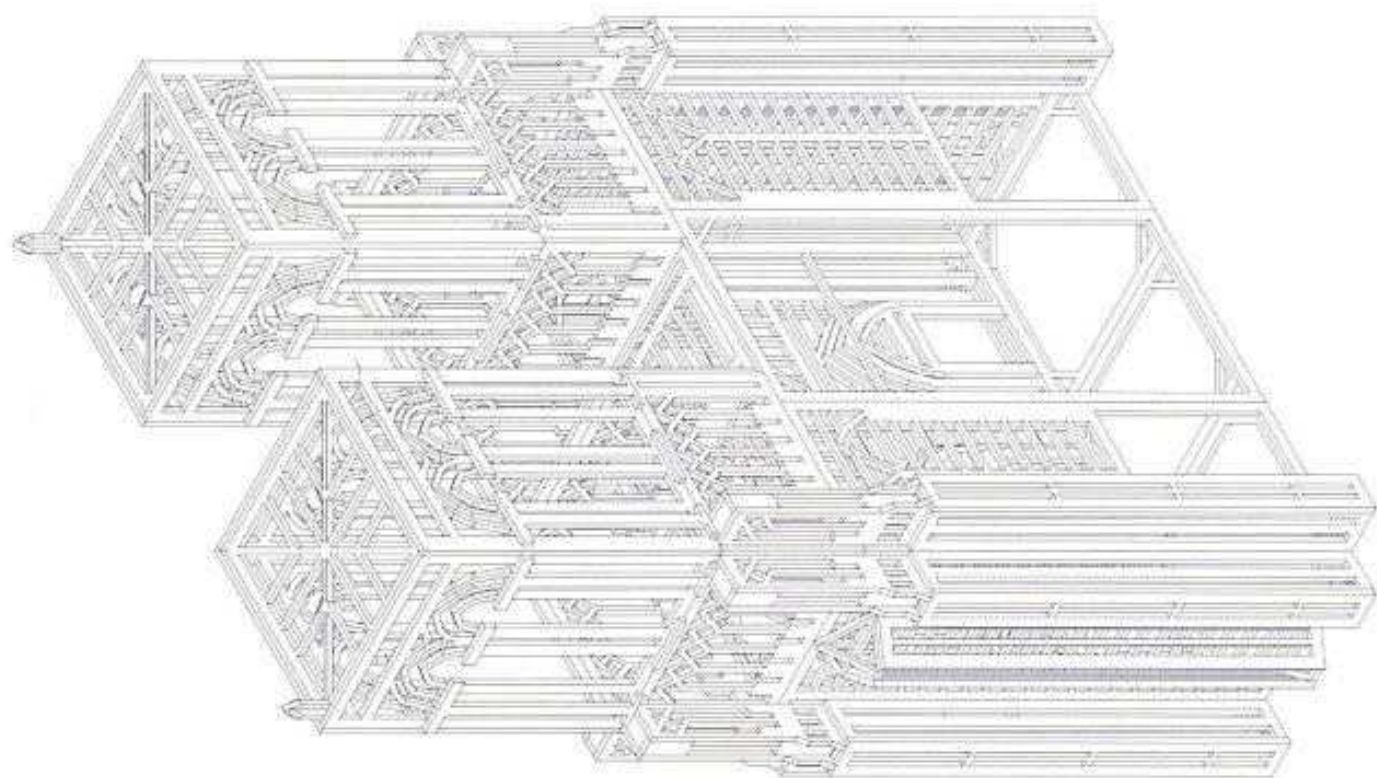

© 2005E Blyssus Inc.

[www.matchitecture.com](http://www.matchitecture.com)

ARCHITECTURE

2x110

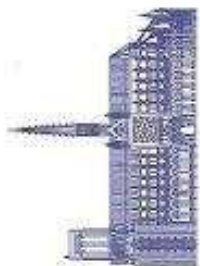
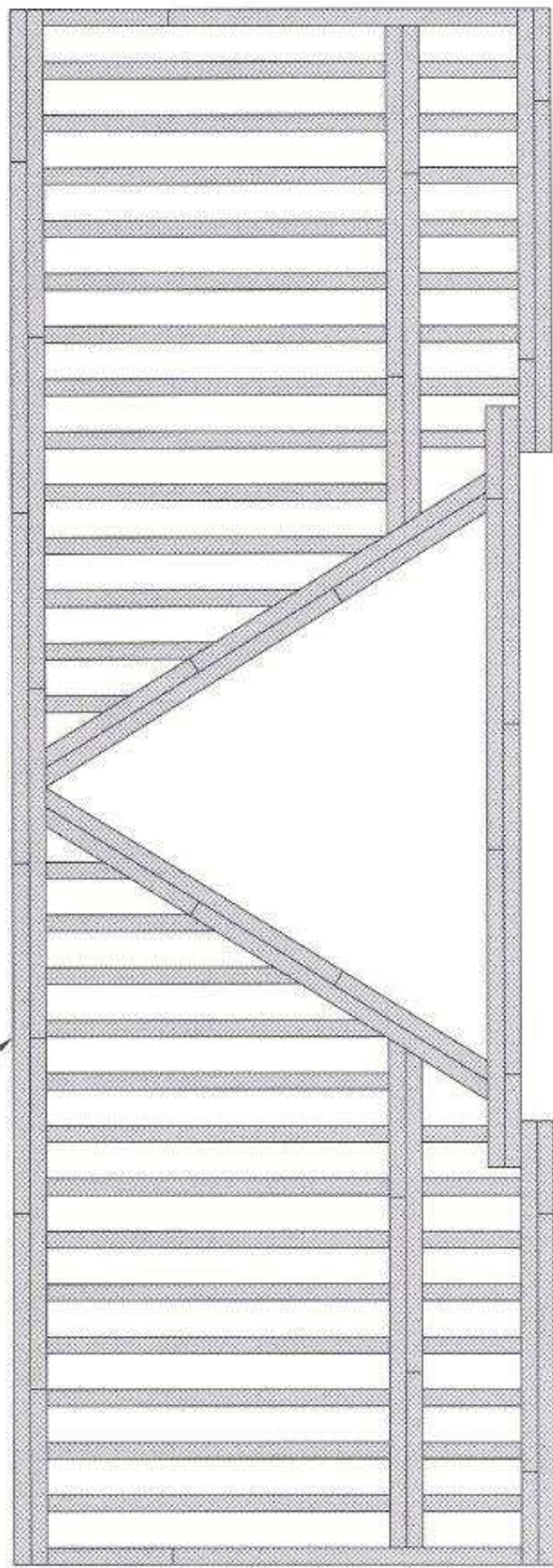

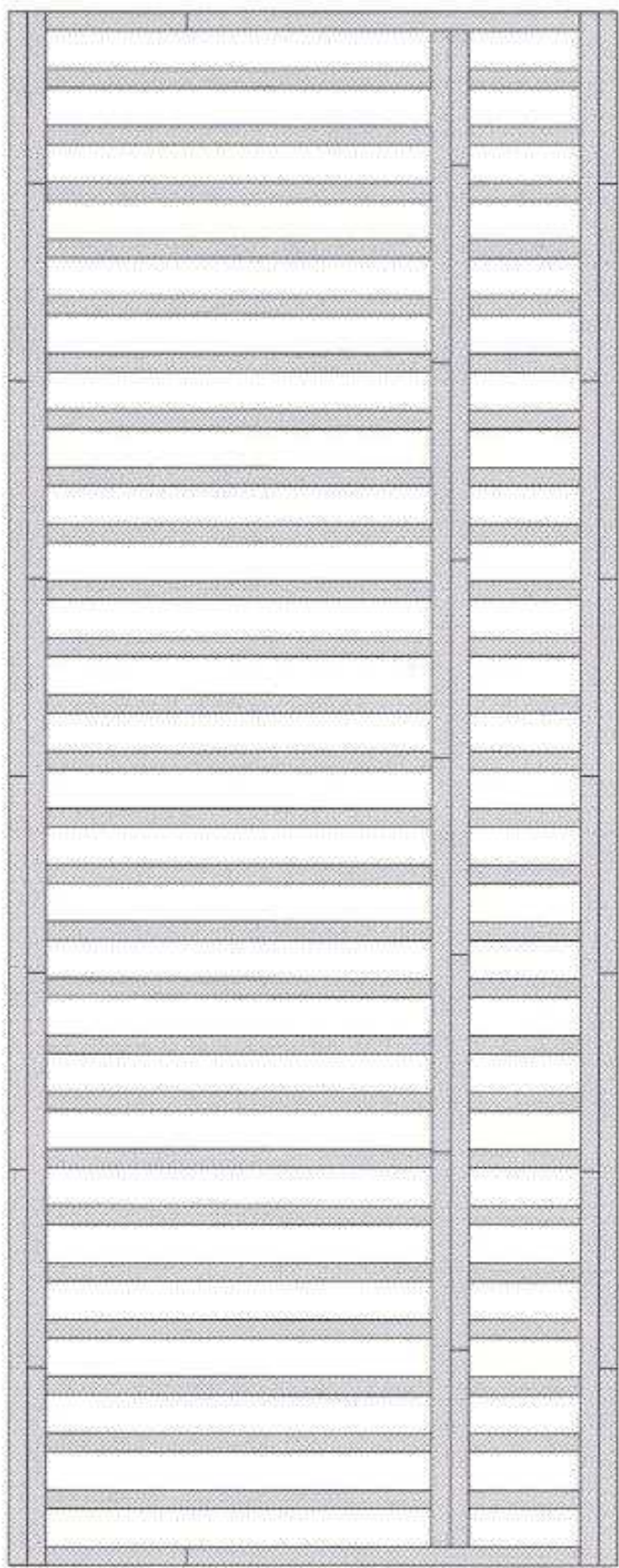

2x111

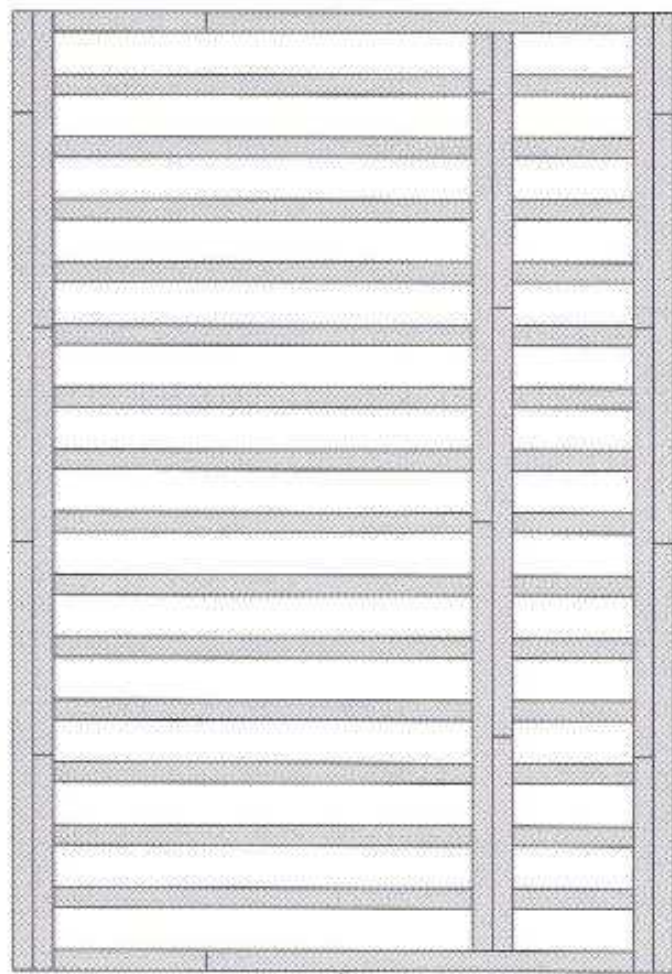

2x112



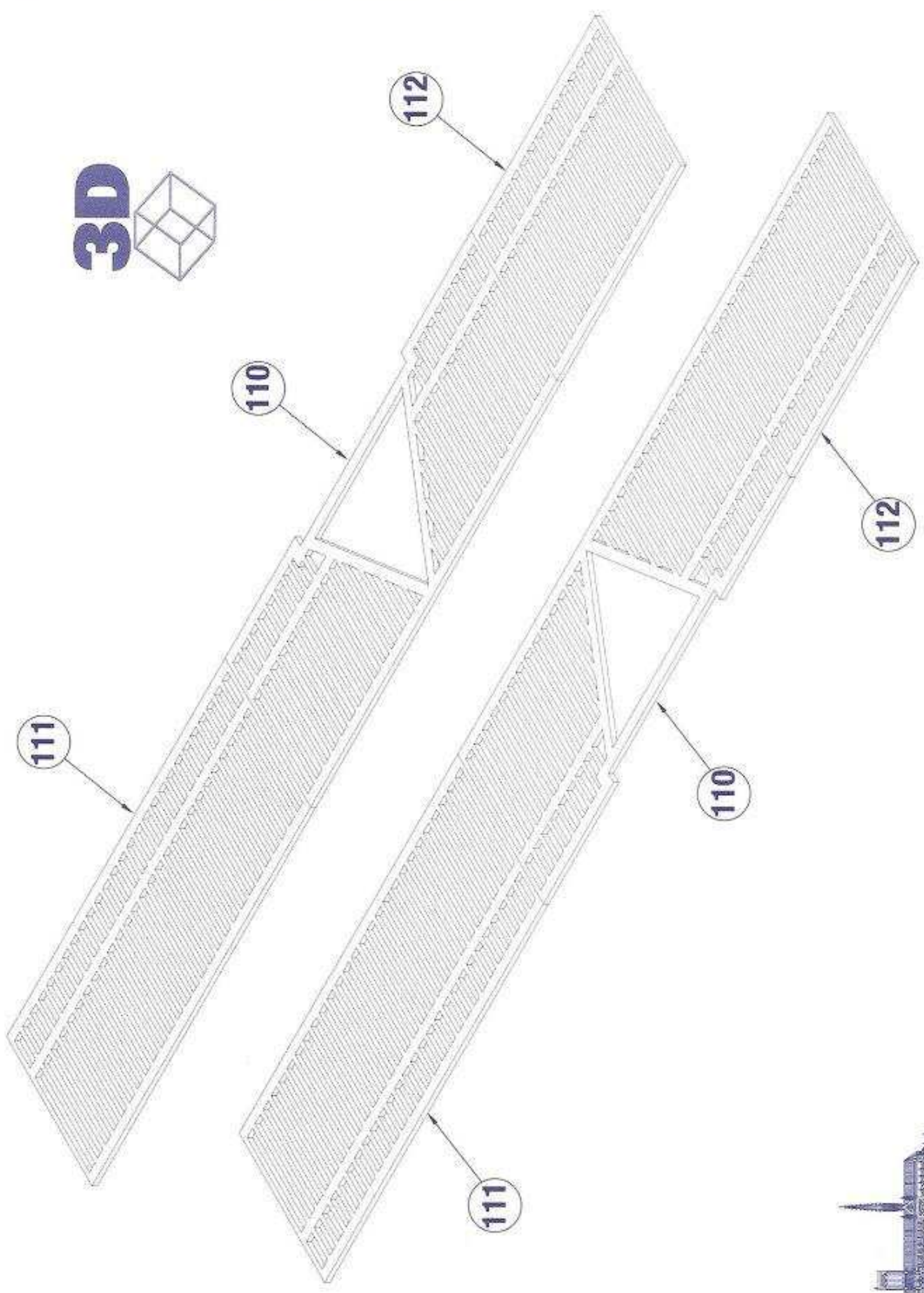
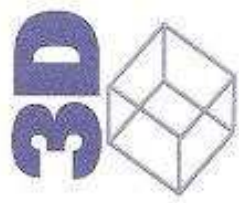

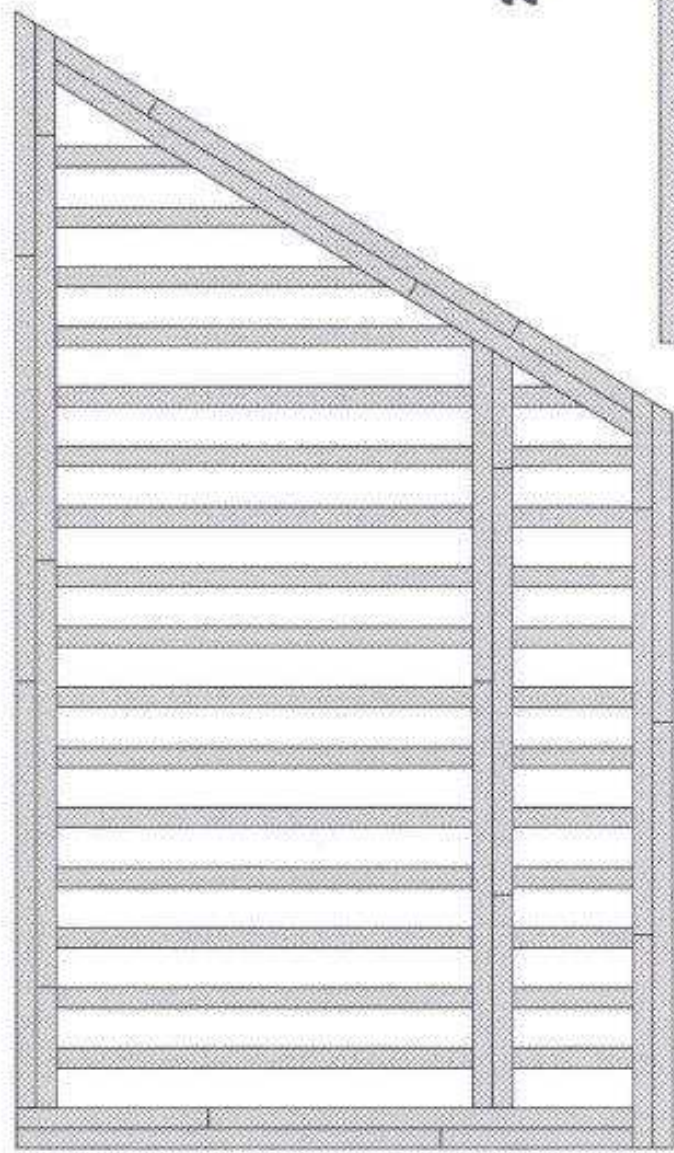

2x114

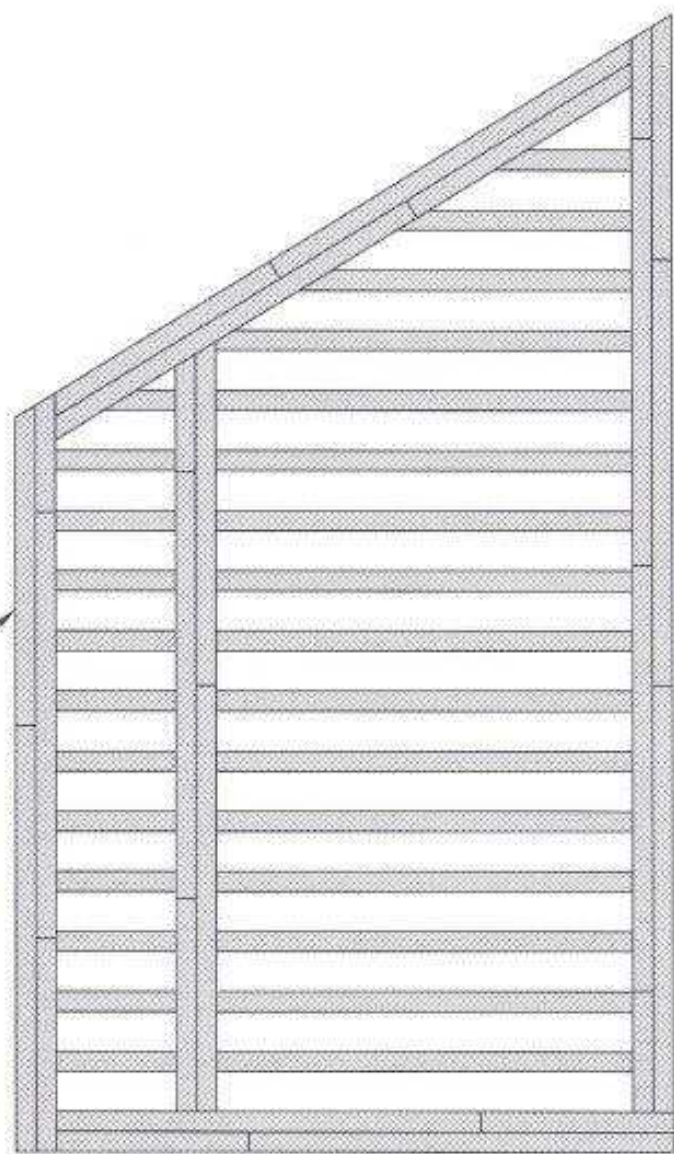

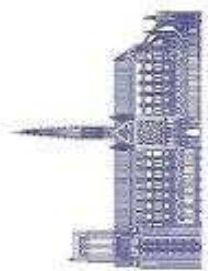

2x113

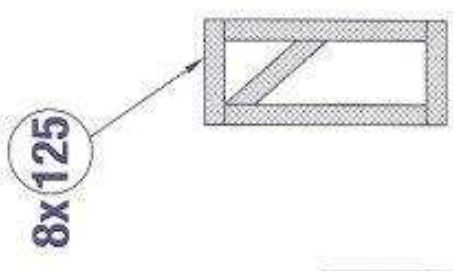
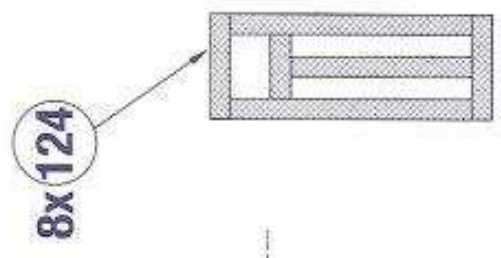
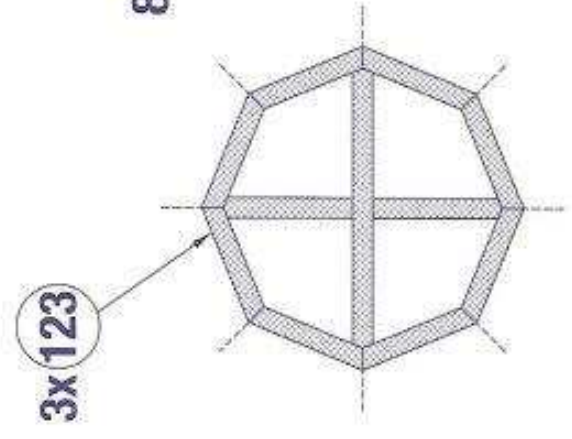
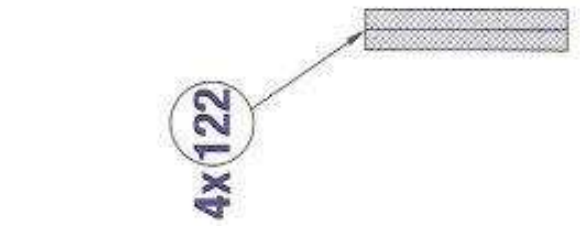
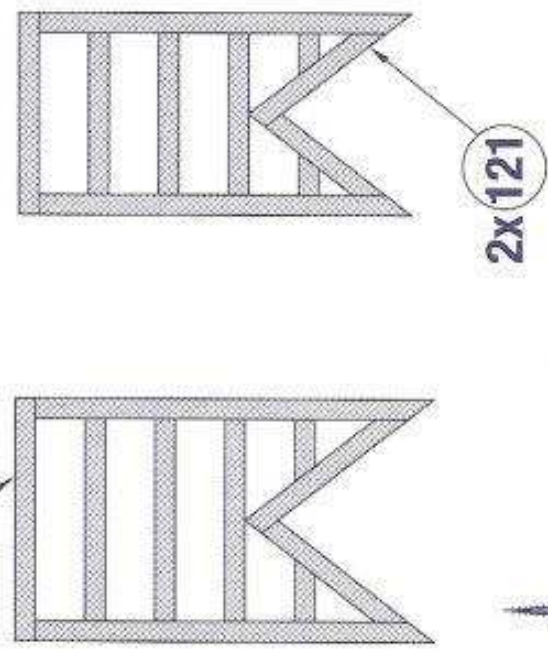
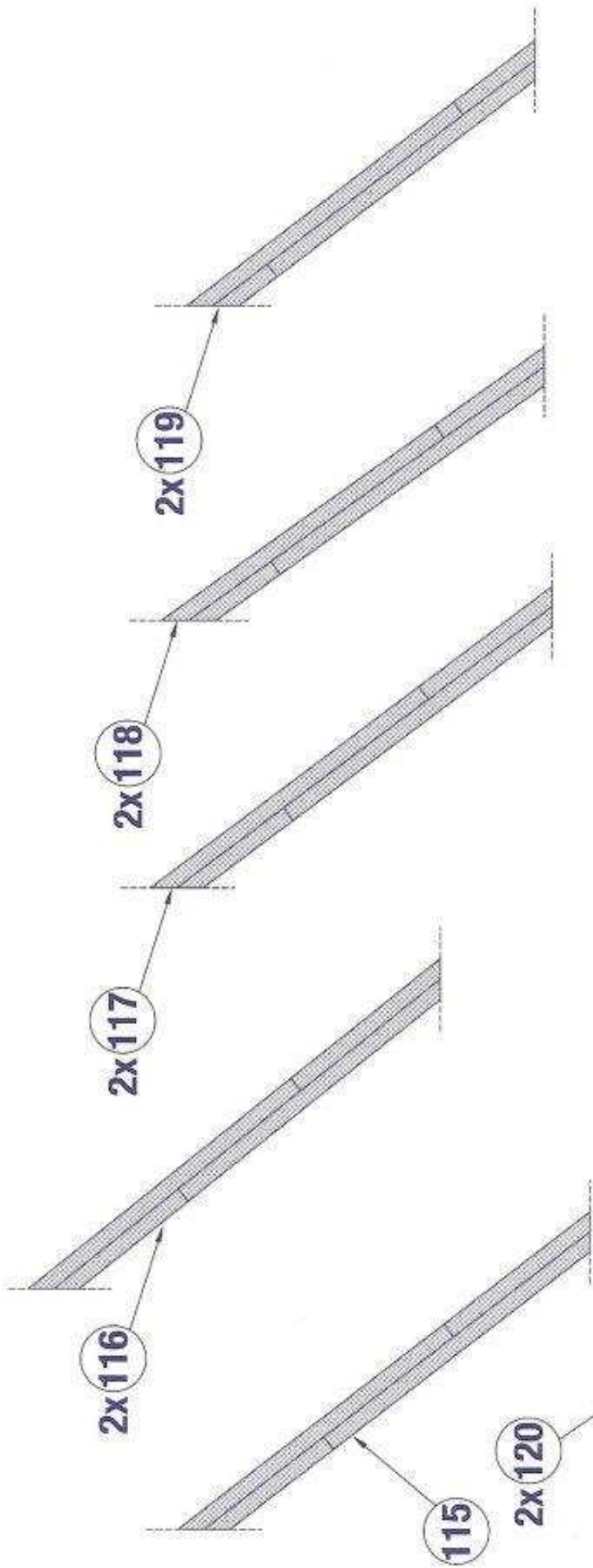

© 2006 Bujdak, Inc.

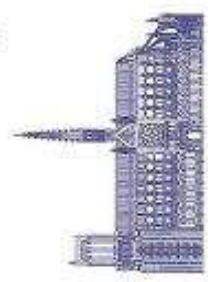
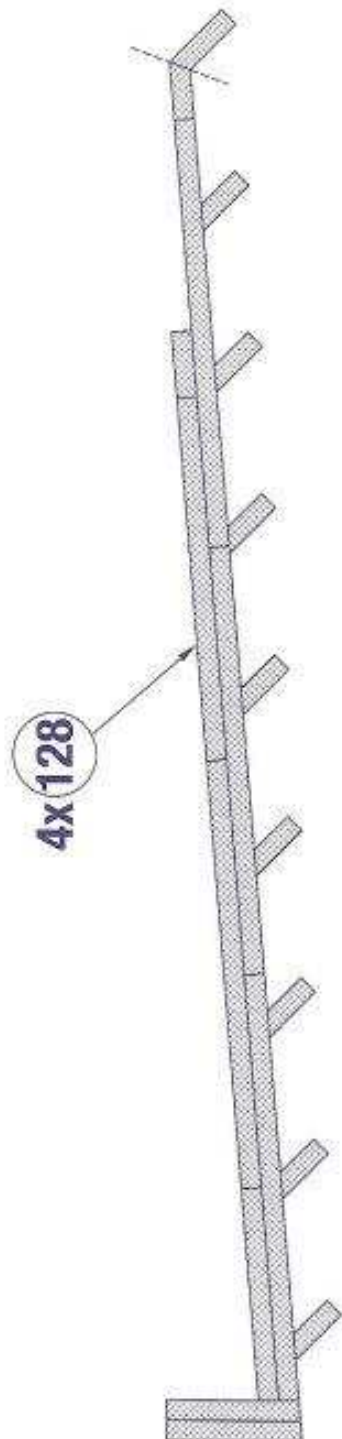
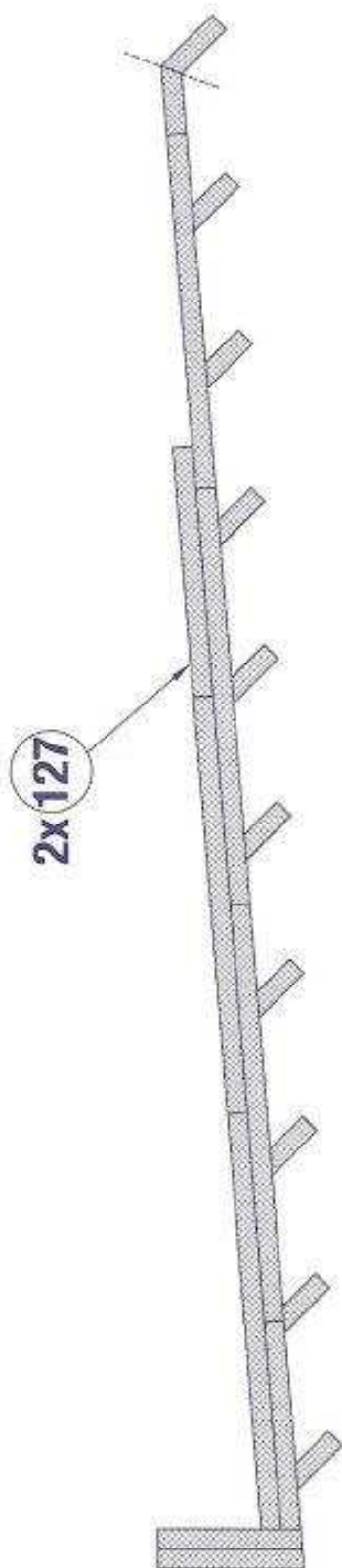
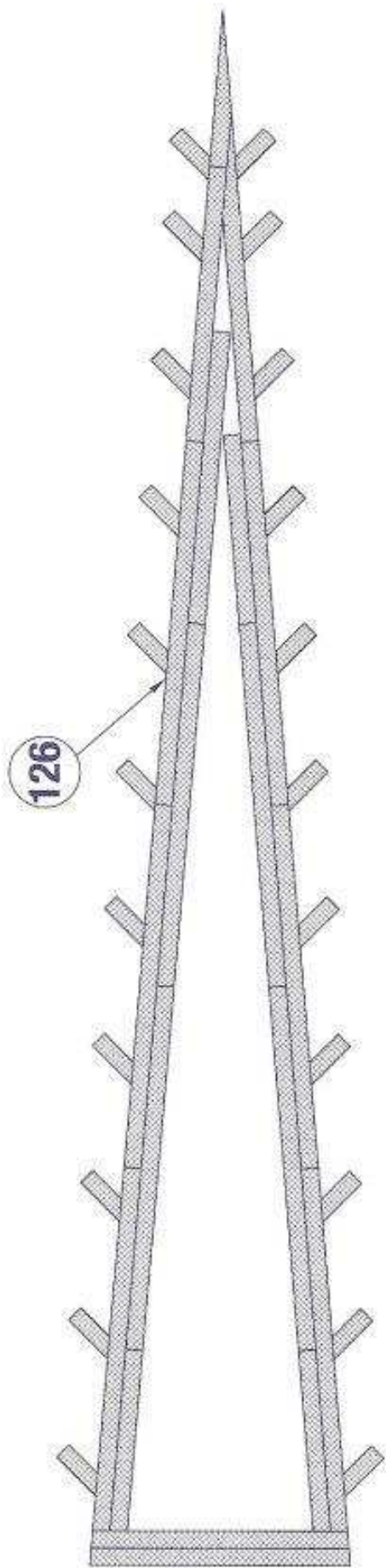



**3D** 

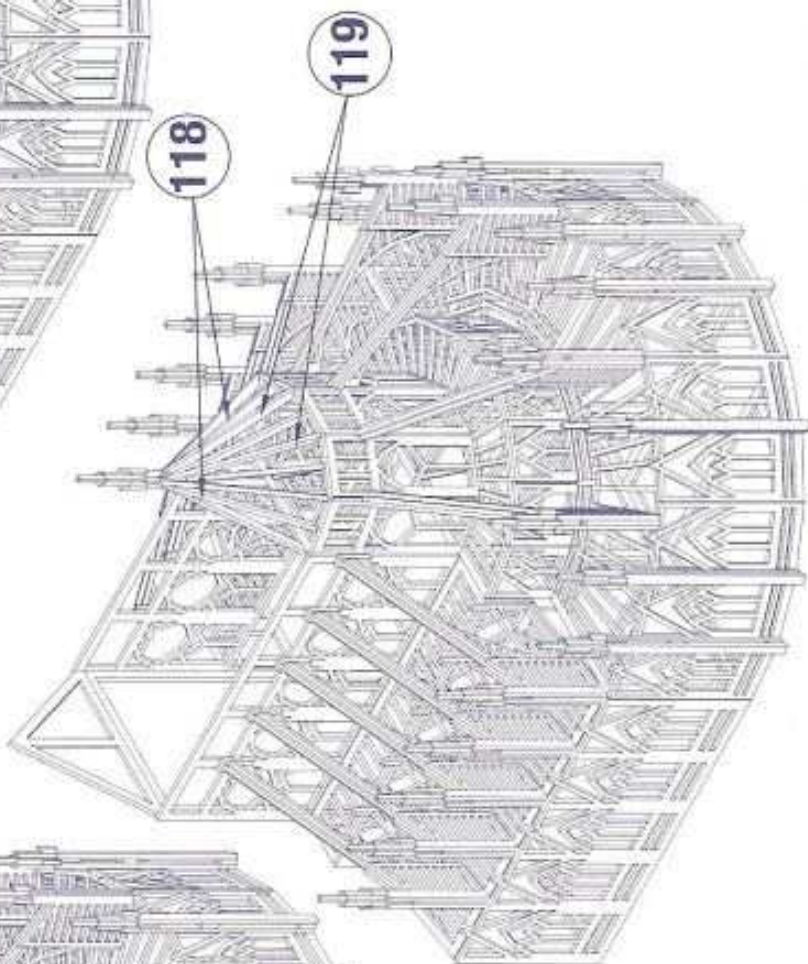
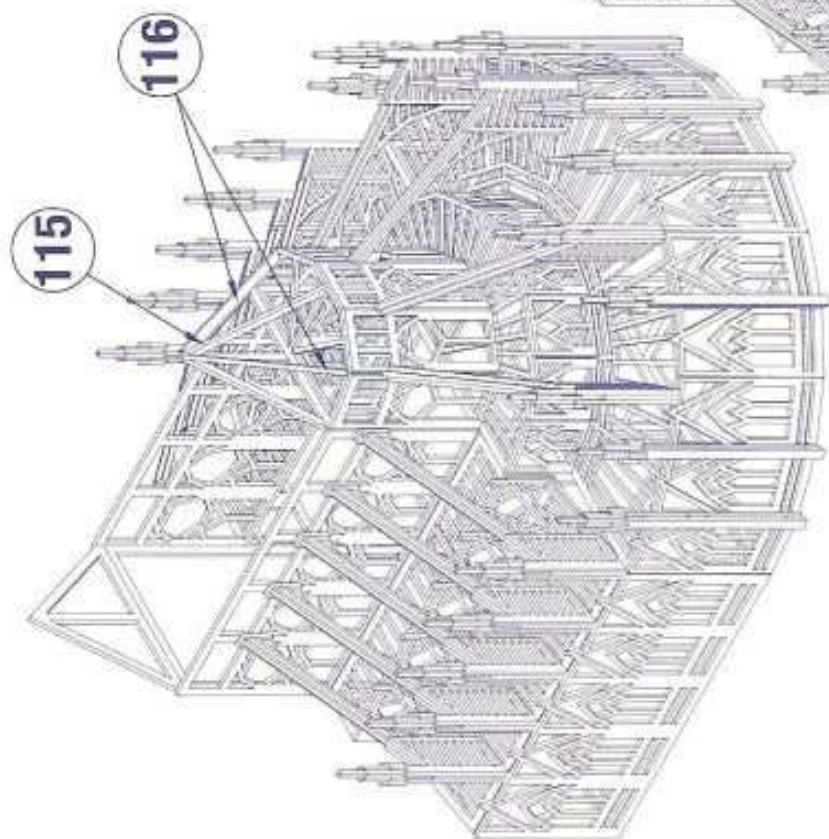
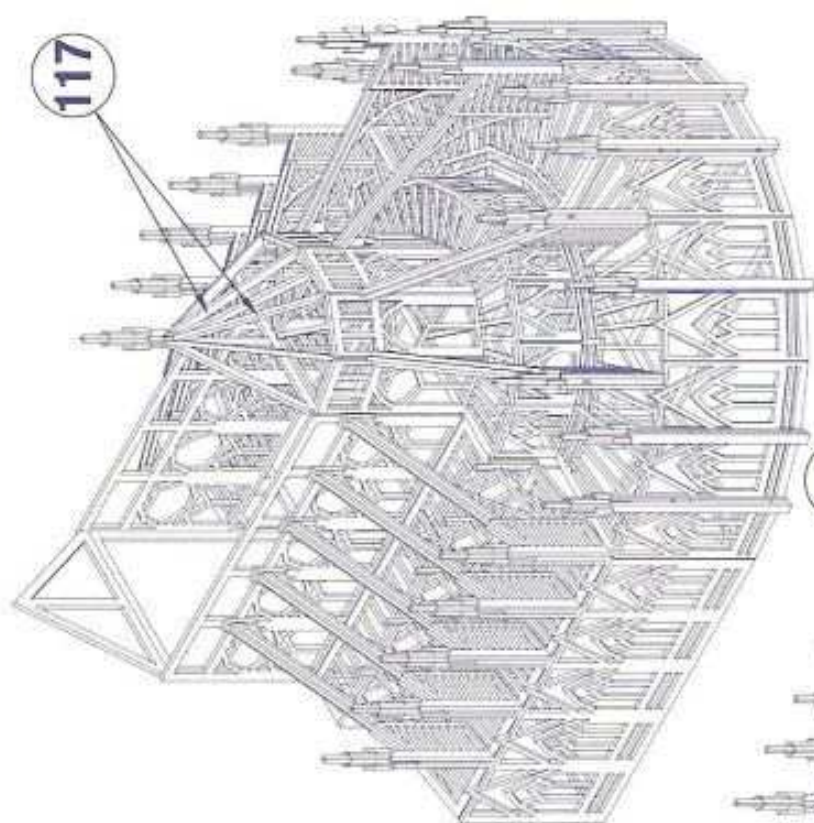

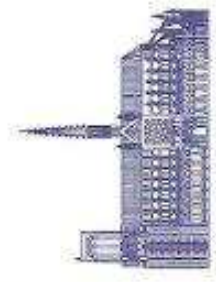
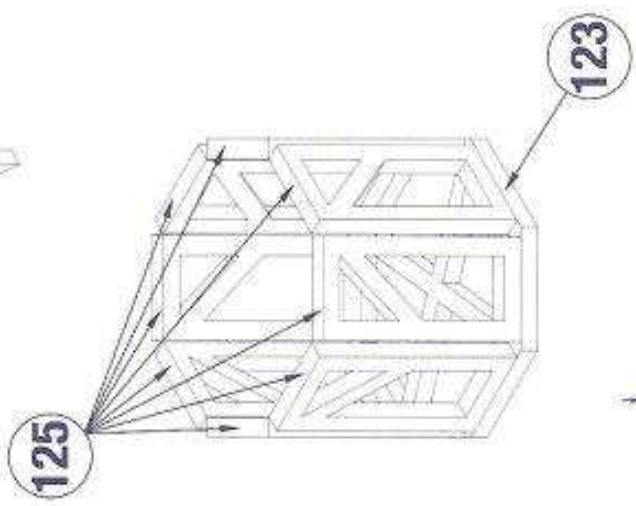
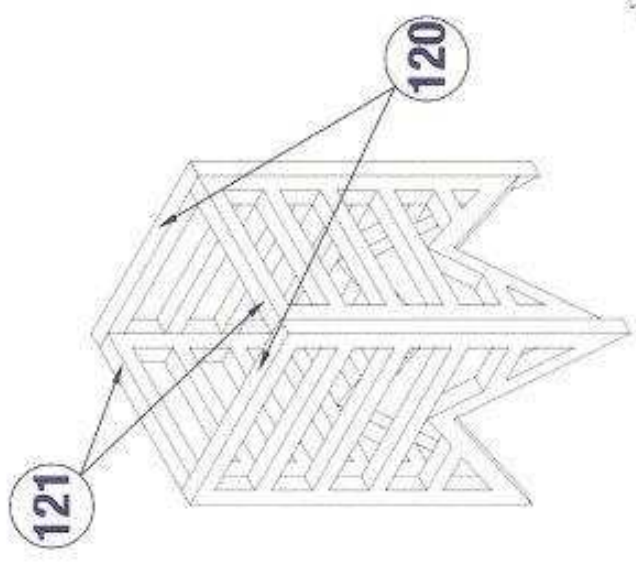
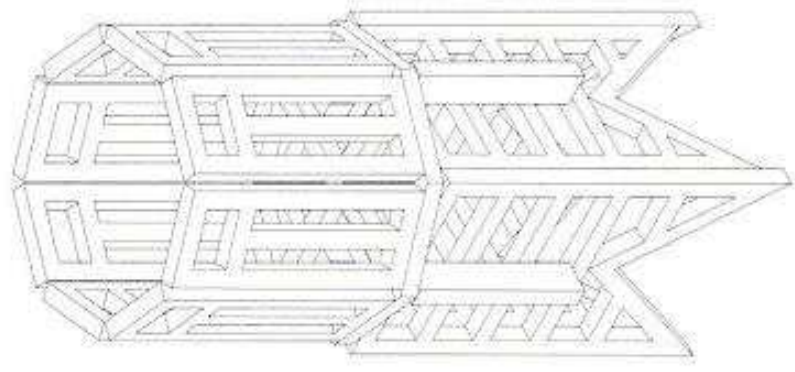
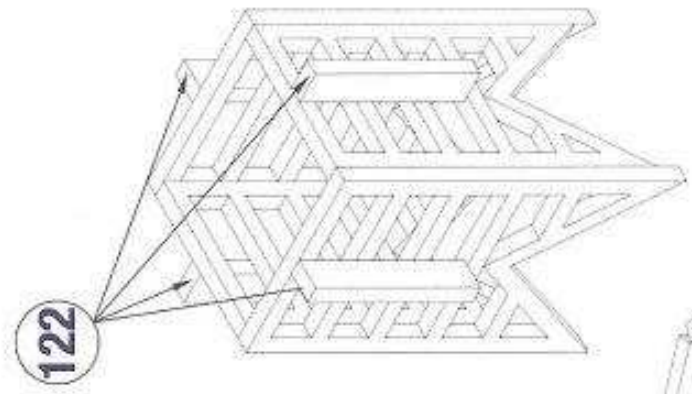
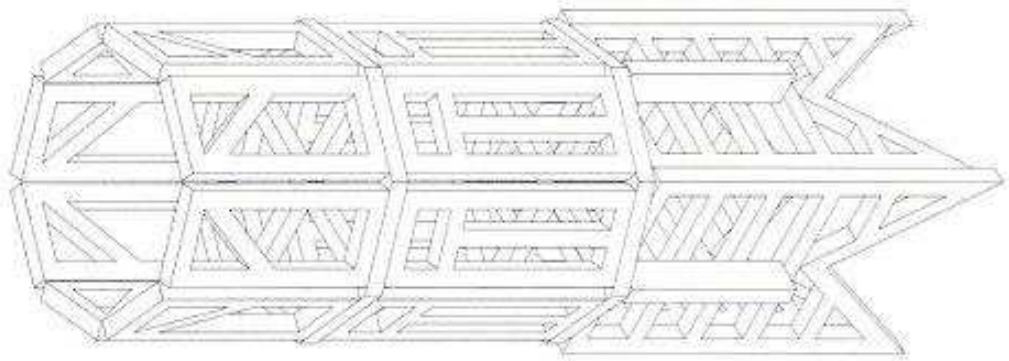
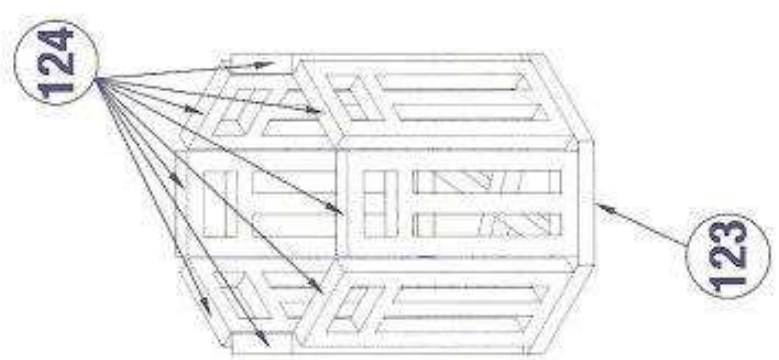

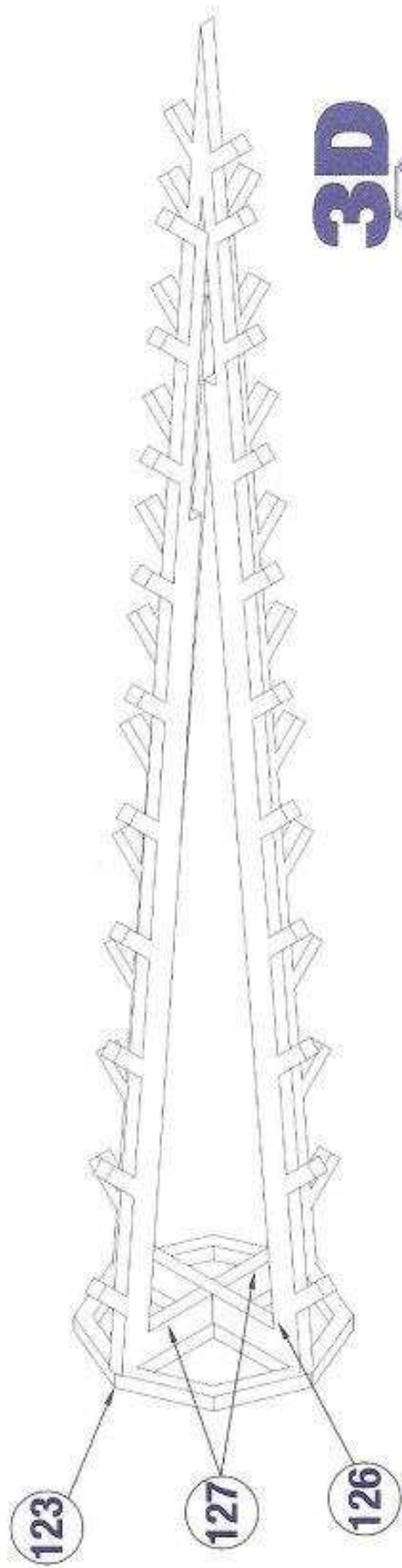

**3D**

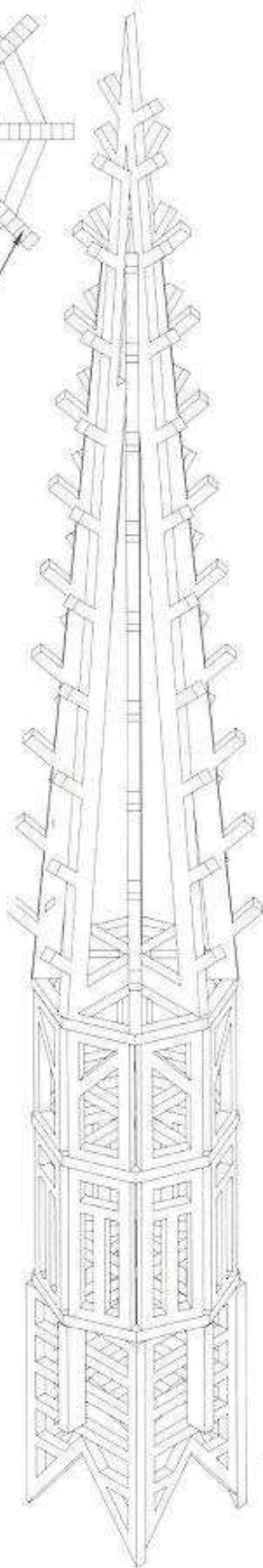
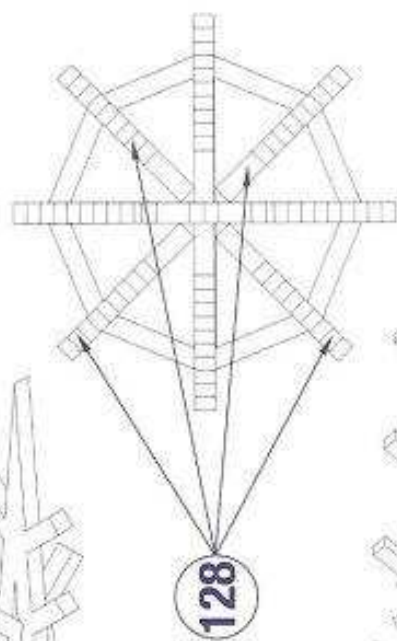
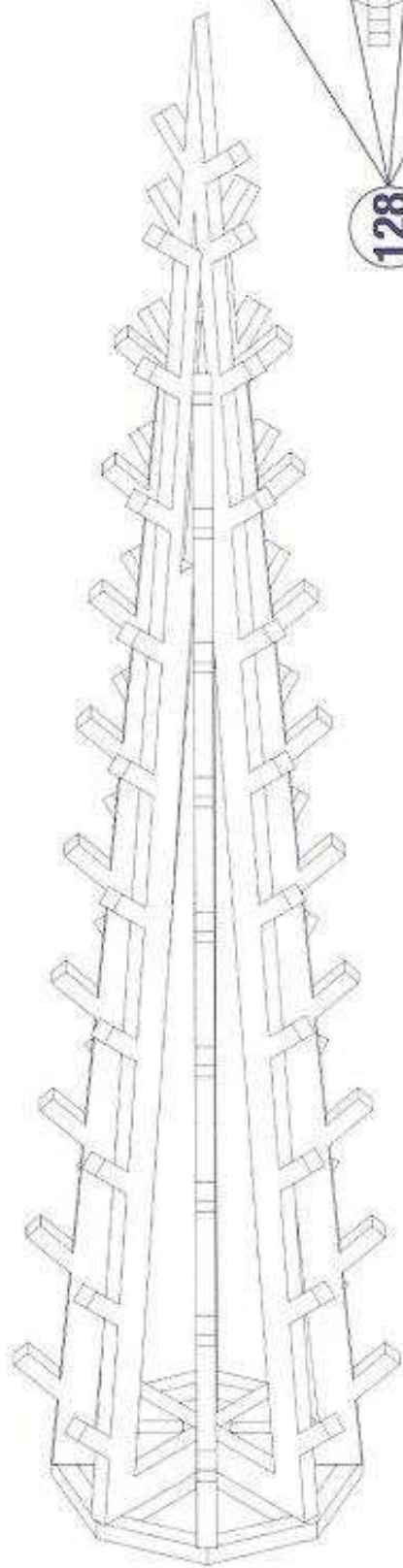

**3D** 

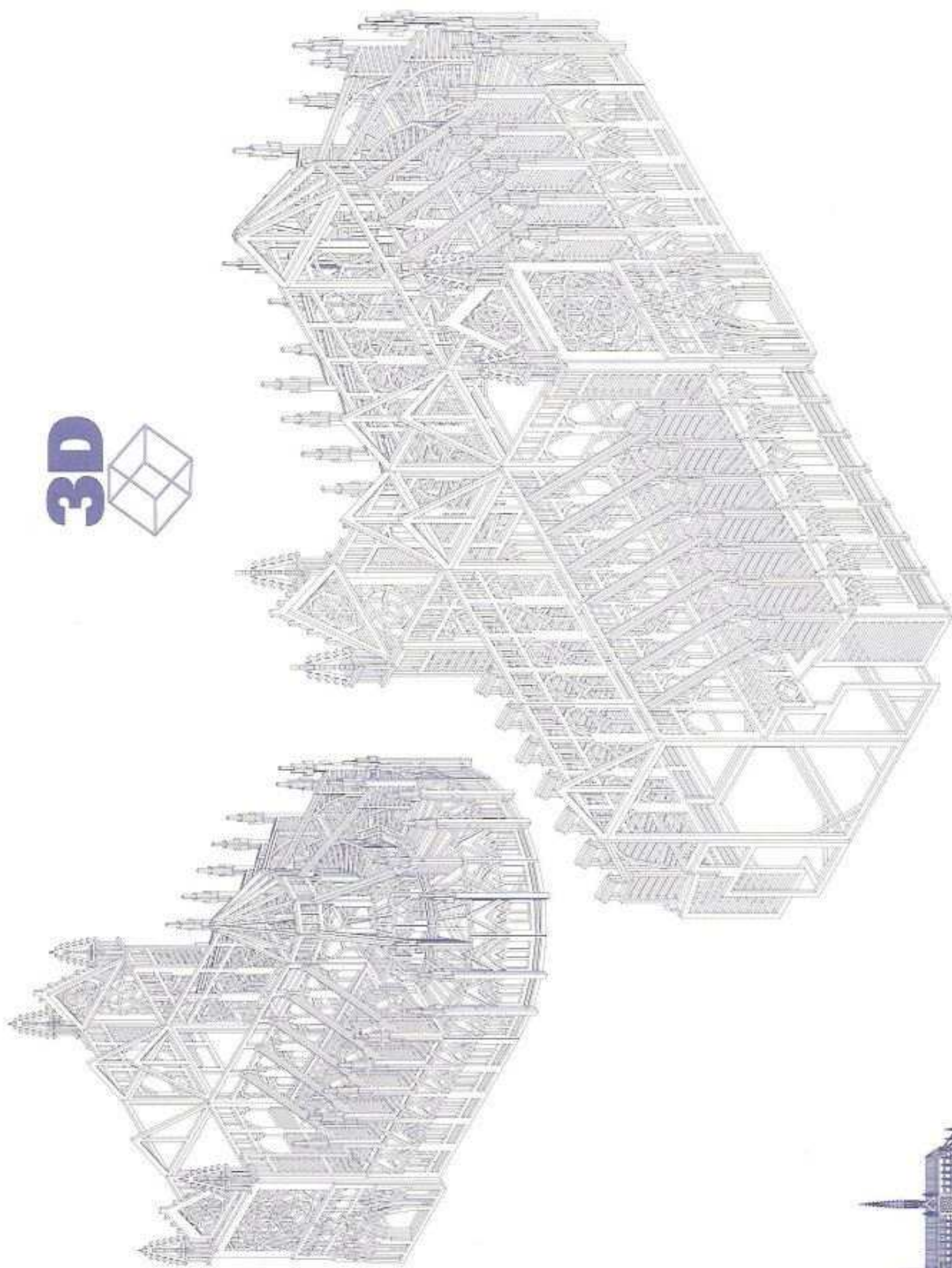

© 2006 Eljetek Inc.

[www.matchitecture.com](http://www.matchitecture.com)

**MATCHITECTURE**

**101** /105

**3D** 

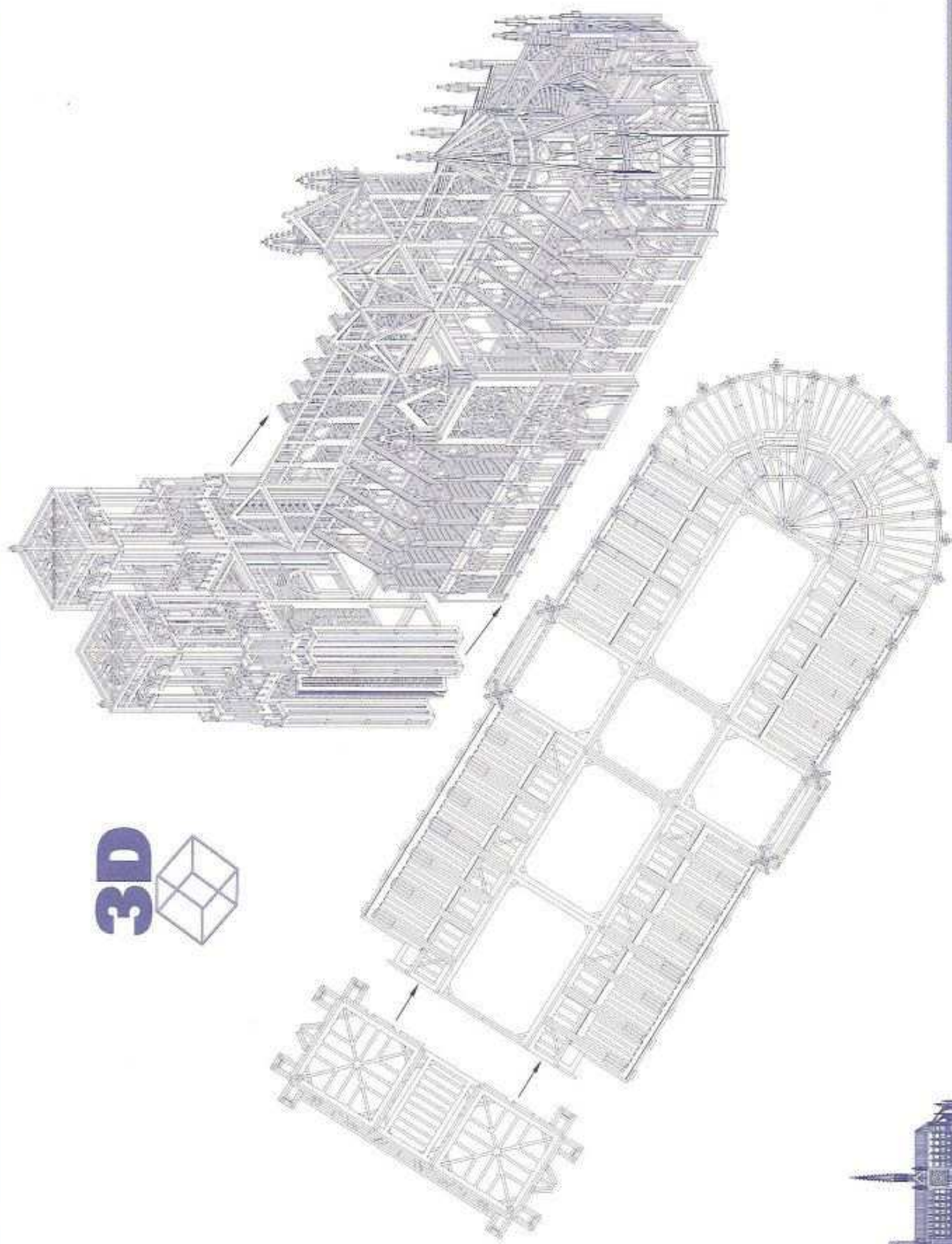

© 2006 Bujoux, Inc.

[www.matchitecture.com](http://www.matchitecture.com)

**MATCHITECTURE**

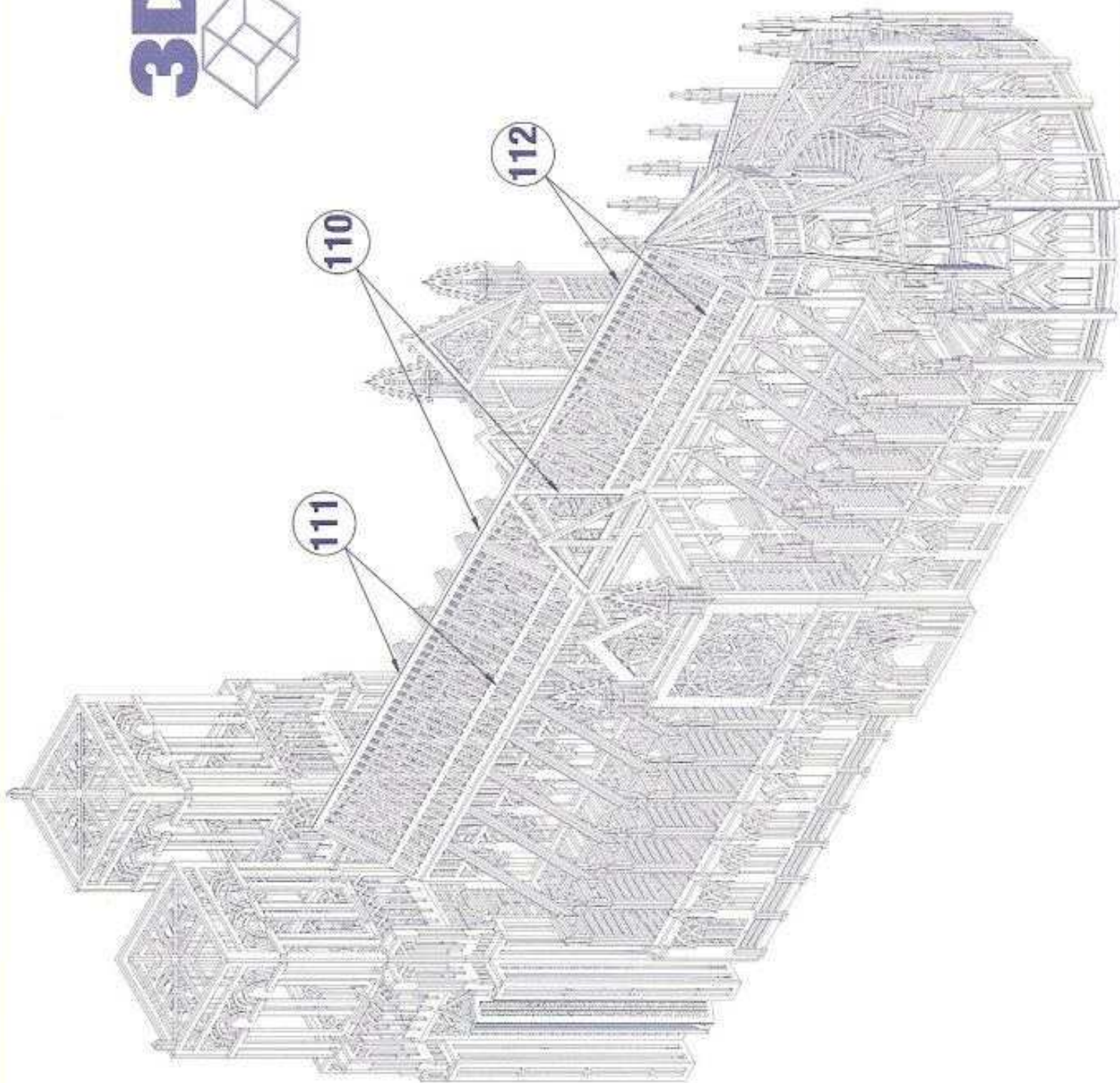
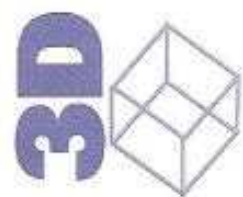

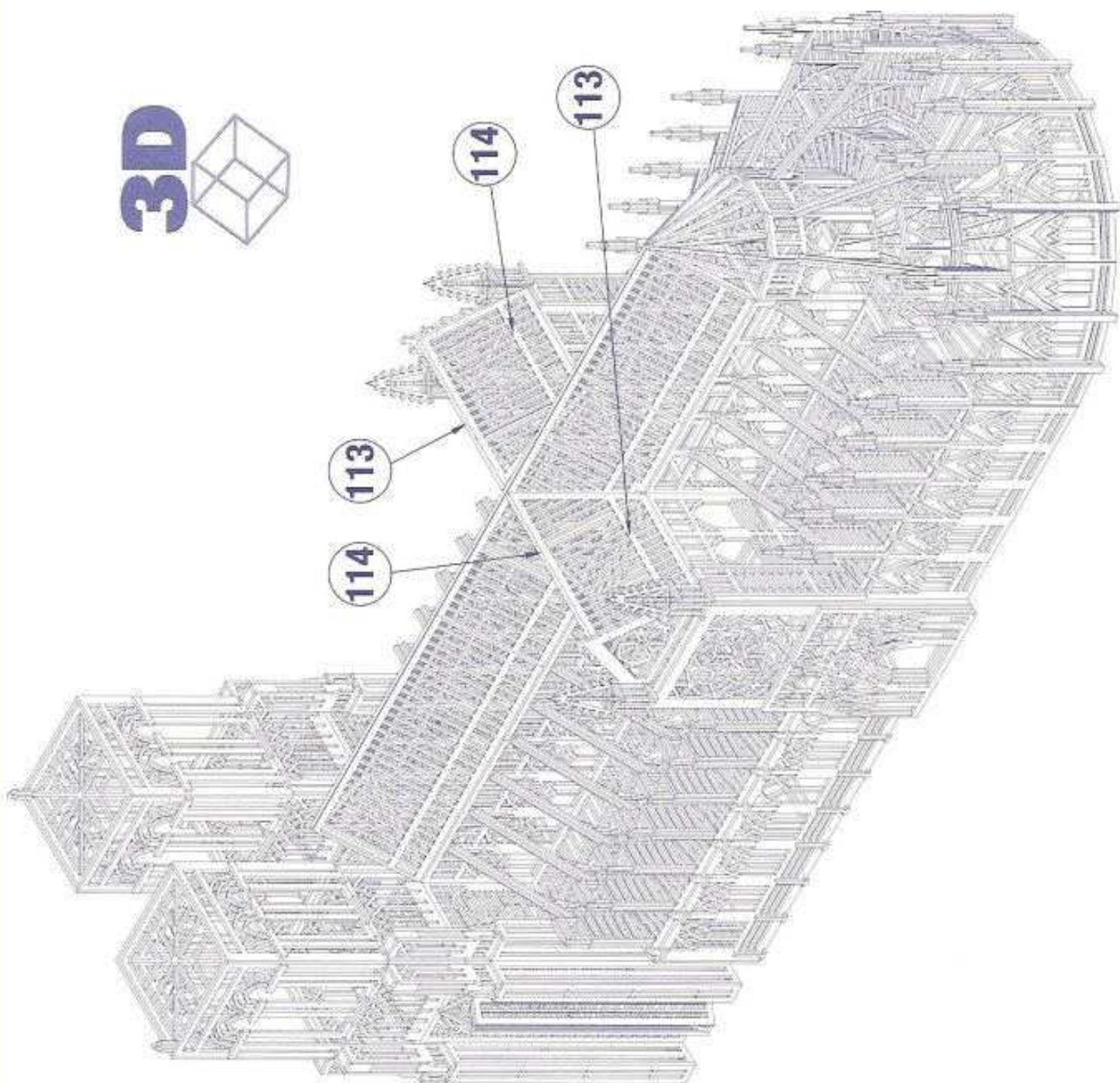
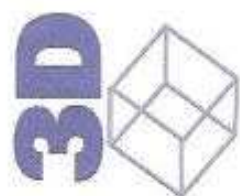

114

113

114

113

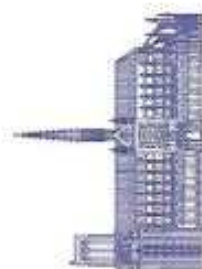

© 2006 Bjeux Inc.

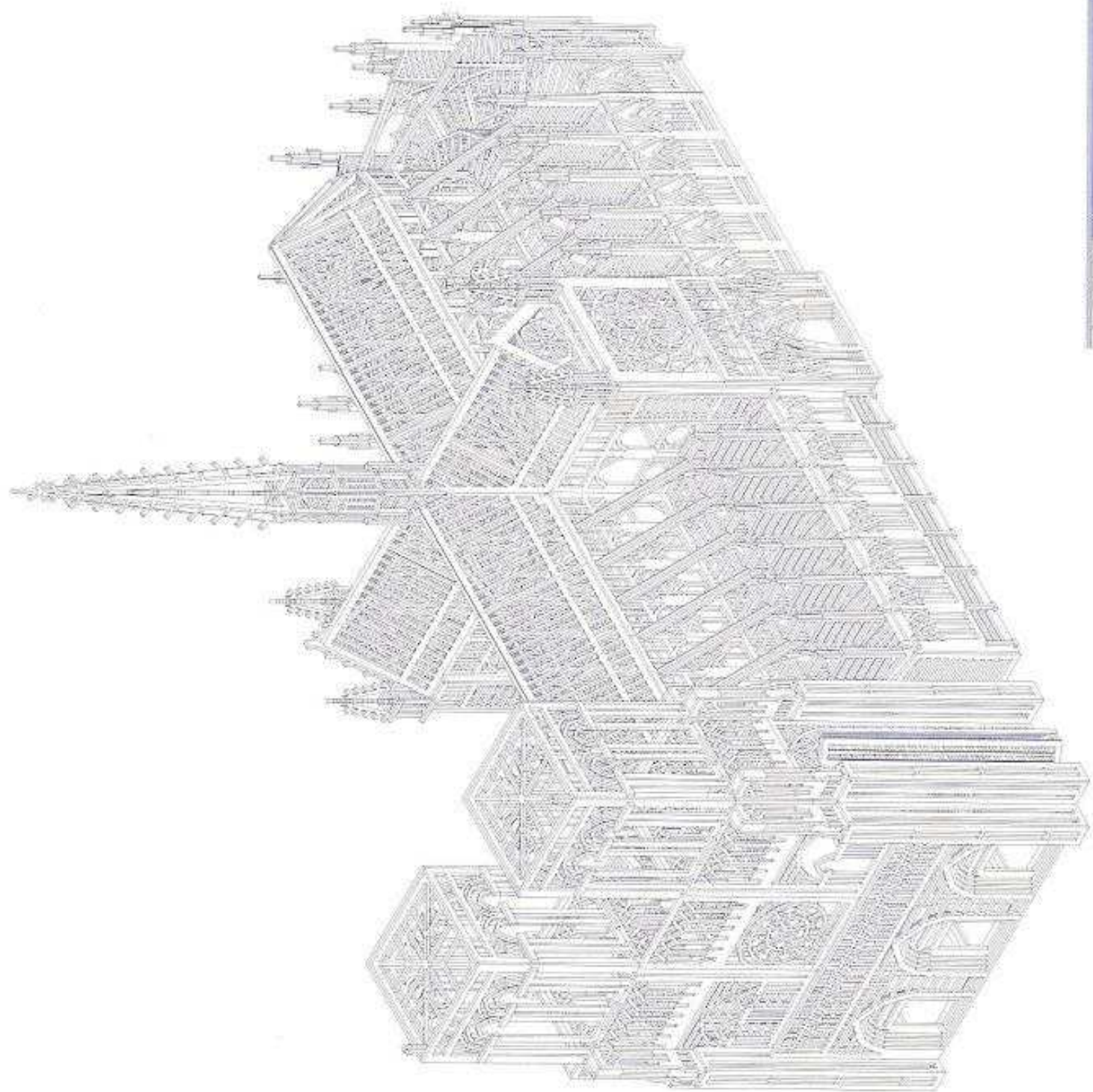

**3D** 

**MATCHITECTURE**

[www.matchitecture.com](http://www.matchitecture.com)

105 / 108

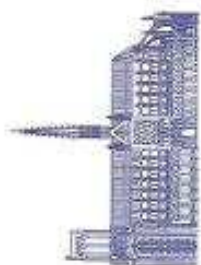

© 2006 Bejean, Inc.